

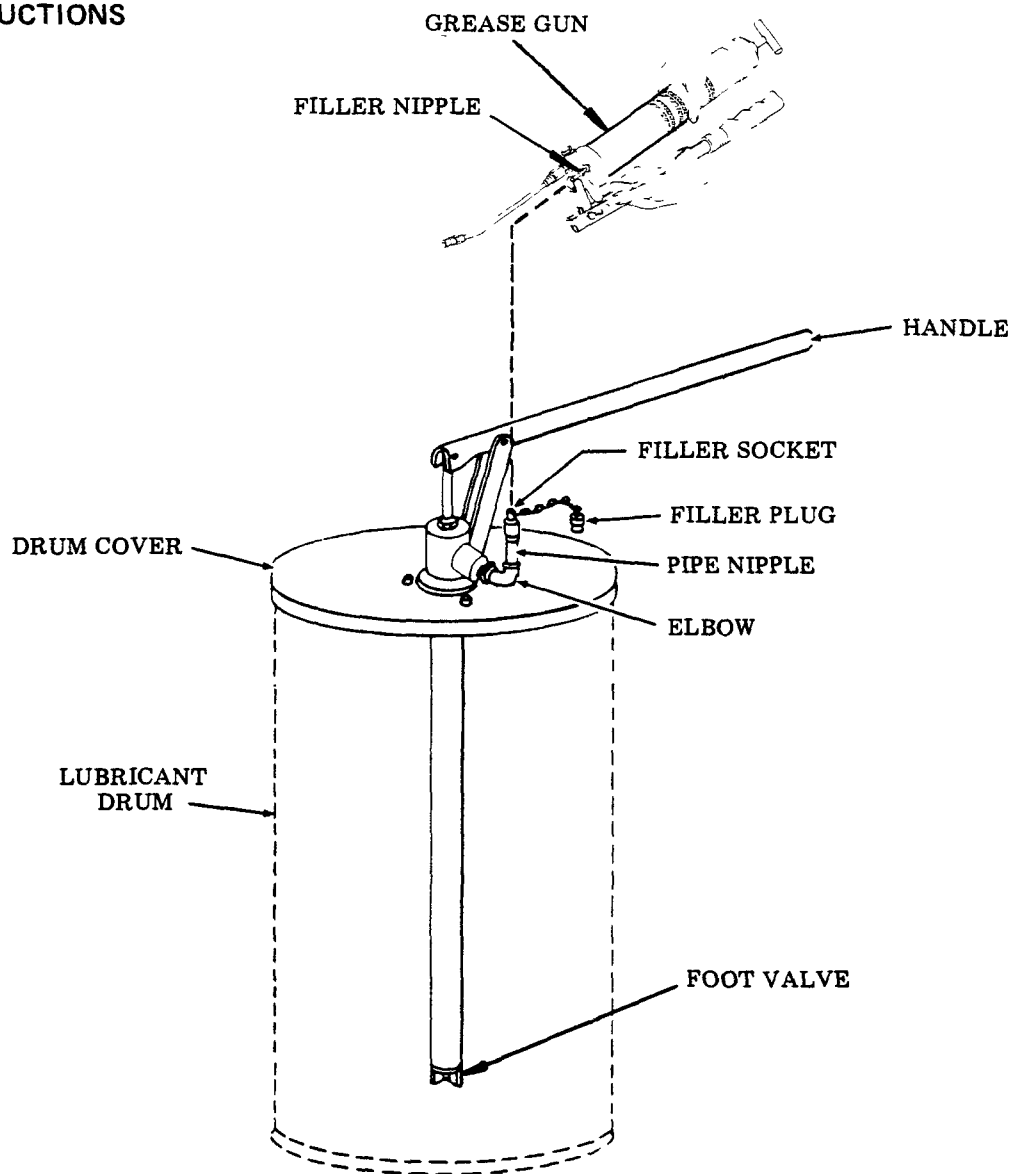

# OPERATING INSTRUCTIONS



## INITIAL PRIMING

It is necessary that the filler pump tube be filled completely with lubricant before attempting to fill a grease gun. To do this, remove the filler socket by unscrewing the pipe nipple from the elbow. Place the pump tube into a fresh drum of lubricant and operate the handle until the lubricant flows from the elbow. Replace the pipe nipple and filler socket.

After the filler pump is primed, the handle cannot be operated unless a filler nipple is inserted in the filler socket. When the filler pump loses its prime, the handle can be operated, which is an indication that the drum is empty. When changing the pump to a fresh drum of lubricant, it will seldom be necessary to reprime, as the pump tube will retain a sufficient volume of lubricant to prevent loss of prime.

The foot valve should be inspected and cleaned frequently, particularly when changing from one drum to another.

## FILLER NIPPLE

Insert filler nipple into the filler socket permitting lubricant to enter the container of the grease gun on each down stroke of the pump handle.

## CAUTION:

If the grease gun container to be filled is of the air-primed type, be sure to open the vent plug in the cover cap to permit the air to escape while loading.

**RETAIN THIS INFORMATION FOR FUTURE REFERENCE**

When ordering replacement parts, list: Part Number, Description, Model Number, and Series Letter.

LINCOLN Electric (314) 679-4200 Customer Service (314) 679-4300 and replacement parts