

120 LB. DRUM

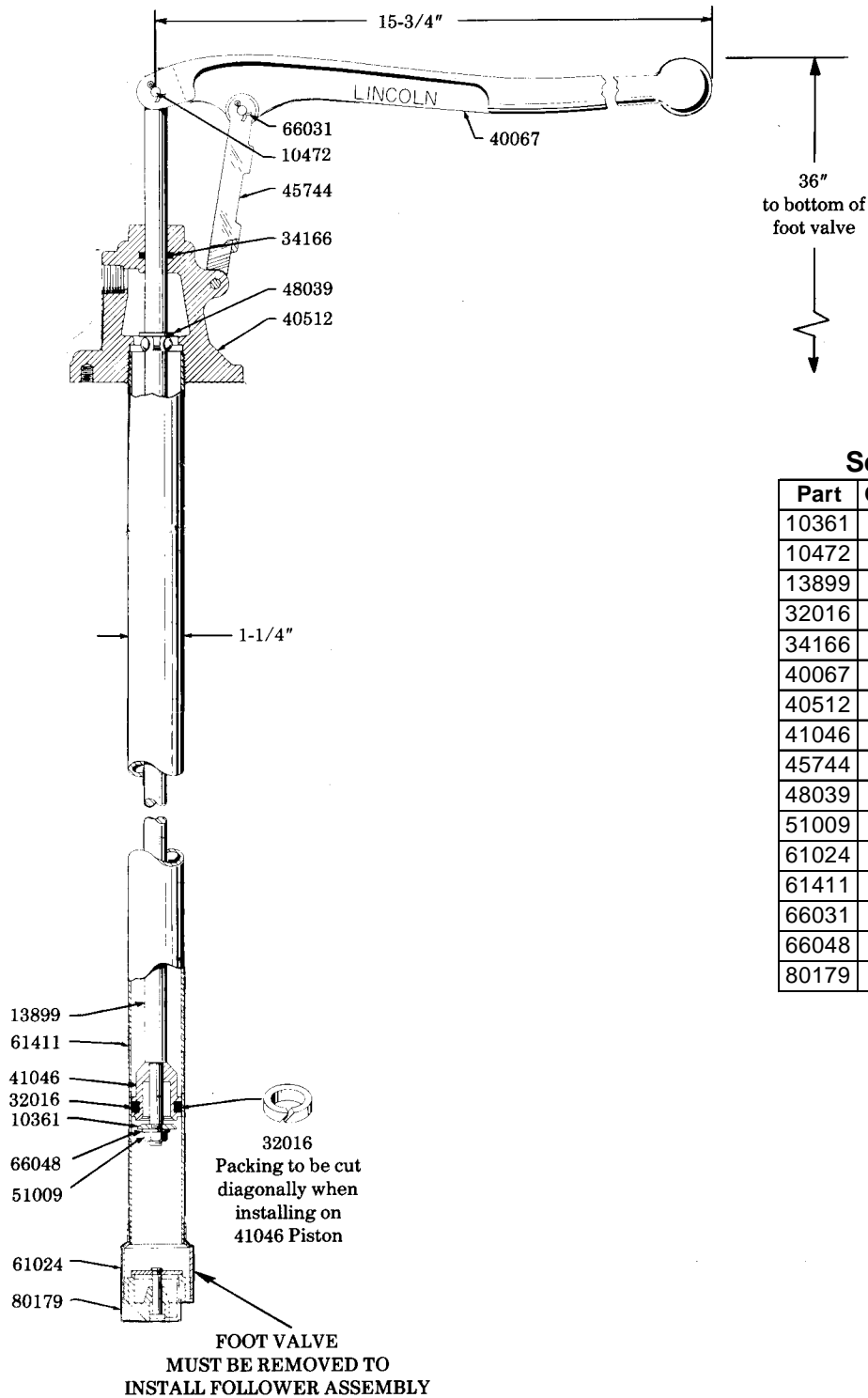

Service Parts

Part	Qty.	Description
10361	1	Piston plate
10472	3	Toggle pin
13899	1	Connecting rod
32016	1	Piston packing
34166	1	O-ring
40067	1	Handle
40512	1	Cylinder head
41046	1	Piston
45744	1	Toggle
48039	1	Packing washer
51009	1	Nut
61024	1	Adapter tube
61411	1	Pumptube
66031	3	Cotter pin
66048	1	Lockwasher
80179	1	Foot Valve

Americas:
One Lincoln Way
St. Louis, MO 63120-1578
USA
Phone +1.314.679.4200
Fax +1.800.424.5359

Europe/Africa:
Heinrich-Hertz-Str 2-8
D-69183 Walldorf
Germany
Phone +49.6227.33.0
Fax +49.6227.33.259

Asia/Pacific:
25 Int'l Business Park
#01-65 German Centre
Singapore 609916
Phone +65.562.7960
Fax +65.562.9967

Copyright 2002
Printed in U.S.A.

Website:
www.lincolnindustrial.com

Section - **B1**
Page - **3A**

OPERATING INSTRUCTIONS

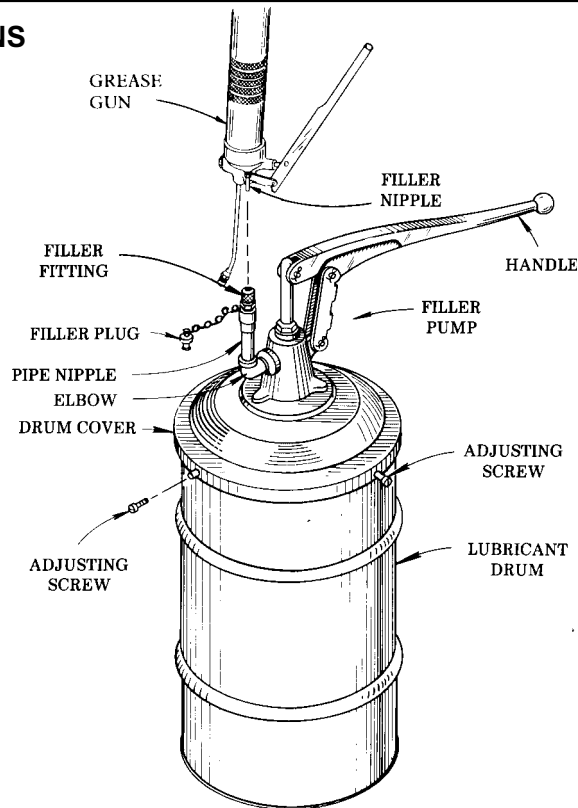

The filler pump is hand operated, designed to lift viscous and semi-solid lubricants from the original drums for loading the containers of the full range of Lincoln grease guns. These grease guns come equipped with a filler nipple for connecting to the outlet of the filler pump, which provides a quick and positive method of filling.

INITIAL PRIMING

It is necessary that the filler pump tube be filled completely with lubricant before attempting to fill a grease gun. To do this, remove the filler fitting assembly by unscrewing the pipe nipple from the elbow. Place the pump tube into a fresh drum of lubricant and operate the handle until the lubricant flows from the elbow. Replace the pipe nipple and filler fitting into the elbow.

FILLER NIPPLE

Insert filler nipple into the filler socket, permitting lubricant to enter the container of grease gun on each down stroke of the filler pump handle.

CAUTION

- 1) If the grease gun container to be filled is of the air primed type be sure to open the vent plug in the cover cap to permit the air to escape while loading.
- 2) After the filler pump is completely primed, the handle cannot be operated unless a filler nipple is inserted in the filler nozzle. When the filler pump loses its prime, the handle can be operated, which is an indication that the drum is empty.+ When changing the pump to a fresh drum of lubricant it will seldom be found necessary to reprime, as the pump tube will retain a sufficient volume of lubricant to prevent loss of prime.
- 3) The foot valve at the filler pump inlet should be inspected and cleaned frequently, particularly when changing from one drum to another.

SERVICE OF LOWER PUMP TUBE

Loss of volume or pressure indicates

- 1) Foreign matter between 41046 Piston and 10361 Piston Check or between 80179 Foot Valve. Remove and clean.
- 2) 32016 Piston Packing or 34166 O-ring worn or damaged. Before replacing piston packing the inside of the tube should be inspected for rough or score marks.

Piston rod surface contacting the 34166 O-ring must be smooth.

RETAIN THIS INFORMATION FOR FUTURE REFERENCE
When ordering replacement parts, list Part Number, Description, Model Number, and Series Letter
LINCOLN provides a Distributor Network that stocks equipment and replacement parts