

SERVICE PARTS SHEET

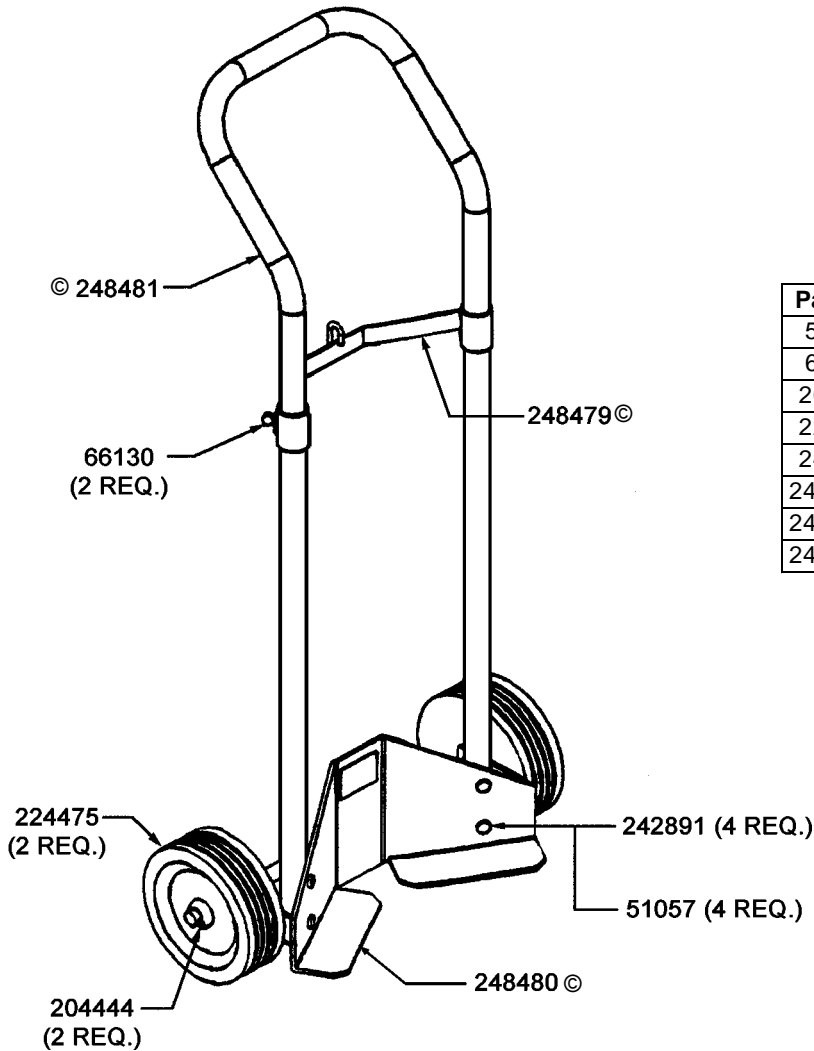

Service Parts

Part No.	Qty.	Description
51057	4	Nut
66130	2	Thumb Screw
204444	2	Cotter Pin
224475	2	Wheel
242891	4	Carriage Bolt
248479©	1	Drum Hook Weldment
248480©	1	Axle Weldment
248481©	1	Hand Truck Handle

Assembly

1. Bolt handle to base with carriage bolts (242891) and nuts (51057).
2. Place wheels (224475) on axle and insert cotter pins (204444) in axle holes. Bend cotter pins at 90 degree angle.
3. Adjust thumb screws (66130) for desired hook-slide height.

© Indicates Change

One Lincoln Way
St. Louis, MO 63120-1578
USA
Phone +1.314.679.4200
Fax +1.800.424.5359

© Copyright 2002
Printed in USA

Web site:
www.lincolnindustrial.com

Section - **B3**

Page - **24A**

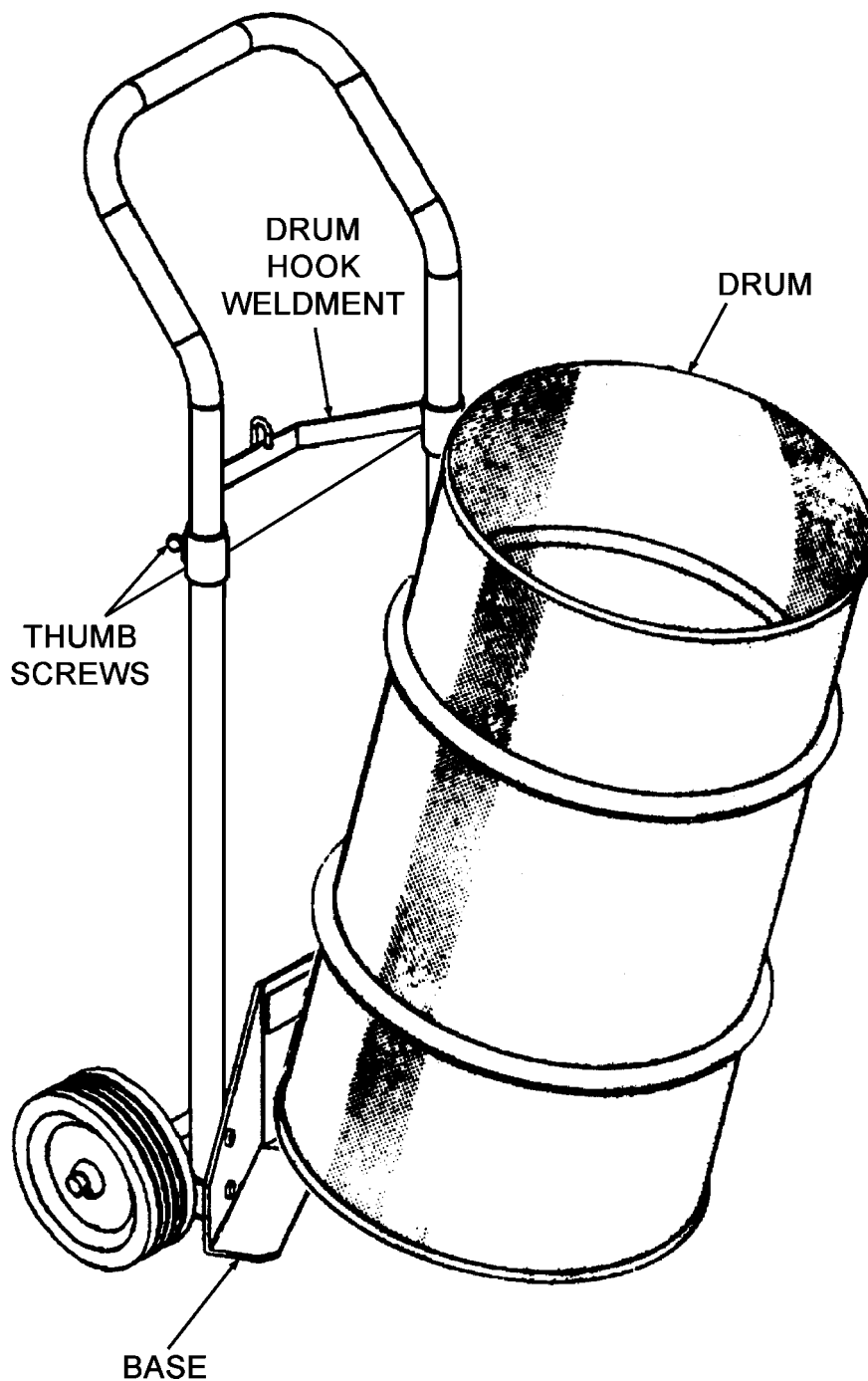

**INSTRUCTIONS FOR CLAMPING DRUM TO
DOLLY TRUCK**

1. Set drum on base.
2. Loosen Thumb Screws (66130).
3. Adjust Drum Hook Weldment (248479) with hook to clamp down.
4. Tighten thumb screw (66130) to hold Drum.