

3610 Drain Pan
(Must be ordered separately.)

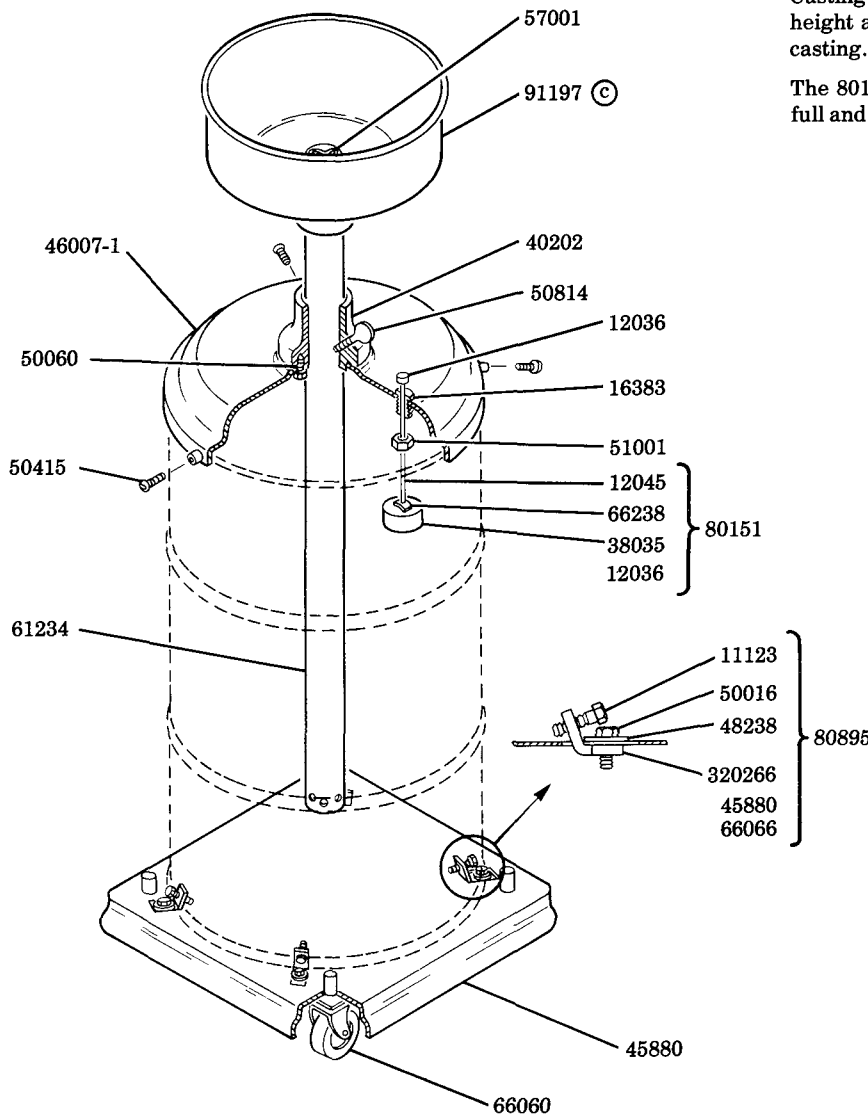

INSTRUCTIONS

Assemble 66060 Casters to the 45880 Base. Center an empty 120 lb. drum on the base and secure with the four base clamps.

Place the 46007-1 Drum Cover on top of the 120 lb. drum and secure with the three 50415 Drum Cover Screws.

Insert the 61234 Drain Tube through the 40202 Guide Casting. The 91197 Funnel may be raised to any desired height and held by the 50814 Thumb Screw in the guide casting.

The 80151 Gauge Float will rise when the drum is nearly full and should be emptied.

SERVICE PARTS

PART	QUAN.	DESCRIPTION
11123	4	Screw
12036	1	Gauge rod knob
12045	1	Gauge rod
16383	1	Gauge rod bushing
38035	1	Gauge floater
40202	1	Guide casting
45880	1	Base
46007-1	1	Drum cover
48238	4	Washer
50016	4	Screw
50060	4	Screw
50415	3	Drum cover screw
50814	1	Thumb screw
51001	1	Hex. nut
57001	1	Catch spring
61234	1	Drain tube
66060	4	Caster
66238	2	Speed nut
80151	1	Gauge float assembly
80895	1	Truck assembly
91197	1	Funnel
360266	4	Clamp

© Indicates change