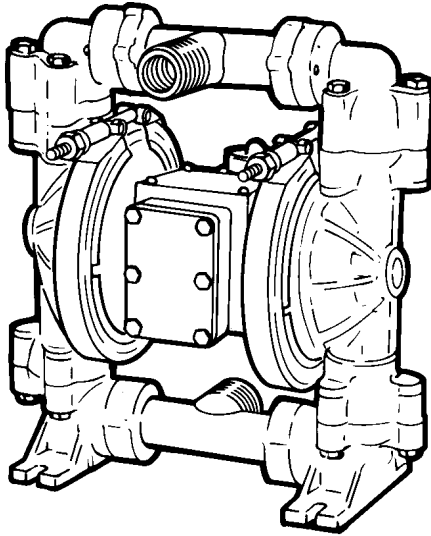

OPERATING INSTRUCTIONS, SERVICE MANUAL
AND REPAIR PARTS LIST

pressure is applied over the entire surface of the diaphragm which is forcing liquid to be discharged by its other side, the diaphragm is operating under a balanced condition during the discharge stroke. This allows the unit to be operated at discharge heads over 200 feet (61 meters) of water head.

Alternate pressurizing and exhausting of the diaphragm chamber is performed by an externally mounted, pilot operated, four way, spool type air distribution valve. When the spool is at one end of the valve body, inlet air pressure is connected to one diaphragm chamber and the other diaphragm chamber is connected to the exhaust. When the spool is moved to the opposite end of the valve body, the porting of chambers is reversed, The air distribution valve spool is moved from one end position to the other in the valve body by means of an internal pilot valve which alternately pressurizes the ends of the air distribution valve spool while simultaneously exhausting the other ends. The pilot valve is positively shifted at each end of the diaphragm stroke by the diaphragm plate's coming in contact with the end of the pilot valve spool and pushing it into position for shifting of the air distribution valve. The chambers are manifolded together with a suction and discharge check valve for each chamber to maintain flow in one direction through the pump.

all external gasketed fasteners for looseness caused by gasket creep. Tighten loose fittings securely to prevent leakage.

AIR SUPPLY

Do not connect the unit to an air supply in excess of 100 PSI (7-0 bars). Install a shutoff valve in the air supply line to permit removal of the unit for servicing. When connecting an air supply of rigid piping, mount a section of flexible line to the pump to eliminate piping strain. In permanent installations, an air line filter is recommended. **The weight of the air supply line and of the filter must be supported by some means other than the air valve cap. Failure to provide support may result in damage to the pump. A pressure regulating valve should be installed to prevent pressure from exceeding recommended limits.**

OPERATION

Your pump has been tested prior to shipment and is ready for use as received. It is completely self-priming and no initial filling with fluid is required.

If the unit is to be totally submerged, the air exhaust must be piped above liquid level to prevent the liquid and foreign material from entering the air distribution valve mechanism.

Open the inlet air valve at least one turn to allow sufficient cycling rate for the pump to prime (30 to 60 cycles per minute). After pumping starts, adjust the inlet air valve for the desired pumping capacity. When further opening of the inlet air valve increases cycling rate without increasing the flow rate, the pump is being starved of liquid due to suction limitations. Further opening of the air inlet valve will waste compressed air. Set the inlet air valve for lowest cycling rate that does not decrease flow rate for most efficient operation.

**CAUTION**

Maximum Operating Pressure, 100 PSI (7 Bar.) and Safe Operating Temperatures of 150°F. (66°C.) Maximum and 40°F. (4.4°C.) Minimum are based upon mechanical stress only and may be significantly altered by pumping certain chemicals. Consult engineering guides for chemical compatibilities and temperature limits.

**WARNING**

Do not use for pumping flammable materials. Build up and discharge of static electricity may result in a fire and/or explosion causing personal injury and loss to property.

Principle of Operation

The pump is powered by compressed air which alternately pressurizes the inner sides of the two diaphragm chambers while simultaneously exhausting the opposite inner chambers causing the diaphragms, which are connected by a shaft, to move endwise. Since air

INSTALLATION PROCEDURES

Position the pump as close as possible to the source of the liquid to be pumped. Avoid long or undersize suction lines and use the minimum number of fittings.

For permanent installation involving rigid piping, install short flexible sections of hose between the pump and piping. This reduces strains and permits easier removal of the pump for service when required. **At time of installation, inspect**

FREEZING OR ICING OF EXHAUST

Icing of the air exhaust can occur under certain conditions of temperature and humidity on compressed air power equipment. When pump performance suffers because of icing, a nonsticky anti-freeze lubricant such as KILFROST, in an air line lubricator, will solve the problem. Icing is more likely to occur at high discharge pressures.

When the pump is used for materials that tend to settle out or transform from liquid to solid form, care must be taken after each use or during idle time to remove them and flush the pump as required to prevent damage.



CAUTION

If a diaphragm fails, the pumped product or fumes can enter the air side of the pump. This side is exhausted through the exhaust port (muffler).

When the product is a hazardous or toxic material, the exhaust should be piped to an appropriate area for safe disposition.

When the product source is at a higher level than the pump (flooded suction), the exhaust should be piped to a higher level than the product to prevent spills caused by siphoning.

MAINTENANCE AFTER USE



CAUTION

Before maintenance or repair, shut off the compressed air line, bleed the pressure, and disconnect the air line from the pump. The discharge line may be pressurized and must be bled of its pressure. When the pump is used for toxic or aggressive fluids, it should be flushed clean prior to disassembly.

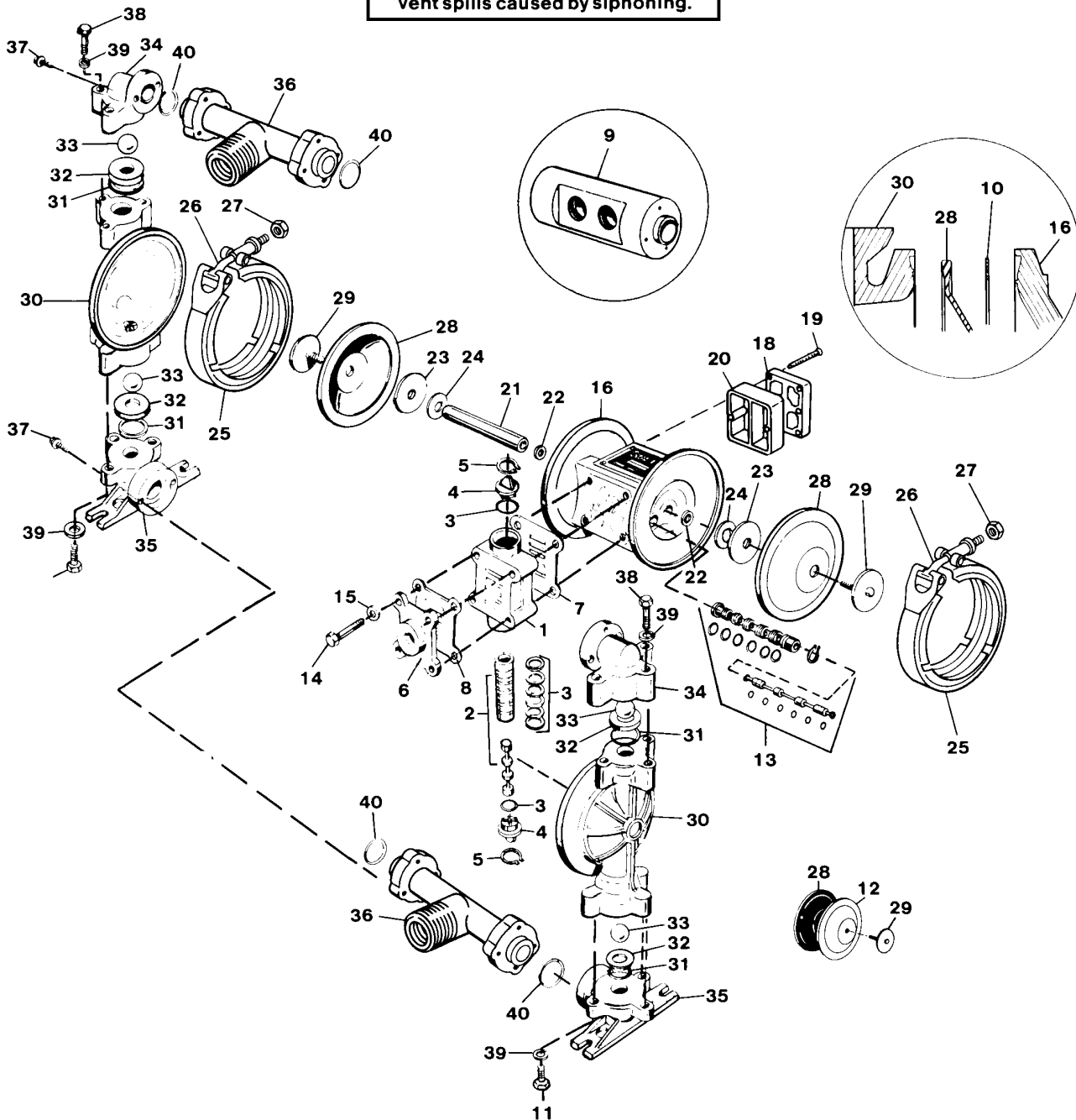

REPAIR KITS AVAILABLE

- ★ 86251 Air End Repair Kit - Both Models
- 86242 Hytrel Wet End Repair Kit - Model 84842
- 86243 Teflon Wet End Repair Kit - Model 84843

SERVICE PARTS

Item	Description	Qty.	Model 84842	Model 84843
1	Spool valve body	1	240734	240734
2	Sleeve & spool set	1	★240736	★240736
3	O-ring	8	★240647 (BN)	★240647 (BN)
4	End cap	2	240648	240648
5	Retaining ring	2	★240649	★240649
6	Valve cap	1	240761	240761
7	Valve body gasket	1	★240762	★240762
8	Valve cap gasket	1	★240763	★240763
9	Manifold dual port (optional)	2	240989	240989
10	Gasket spacer	2	●240755 (BN)	■240755 (BN)
11	Hex head capscrew	6	240715	240715
12	Overlay diaphragm	2	----	■240656 (TF)
13	Pilot valve assembly	1	★244037	★244037
14	Hex head capscrew	4	240658	240658
15	Flat washer	4	240659	240659
16	Intermediate bracket	1	240764	240764
17	(no longer used)	-	----	----
18	Muffler cap	1	244488	244488
19	Self-tapping screw	6	244489	244489
20	Muffler	1	244487	244487
21	Diaphragm rod	1	240665	240665
22	Rod seal	2	★240666	★240666
23	Inner diaphragm plate	2	240767 (PP)	240767 (PP)
24	Bumper	2	★240668	★240668
25	V-band clamp assembly (includes Items 26 & 27)	2	243105	243105
26	Tee bolt	2	243103	243103
27	Hex nut	2	243104	243104
28	Diaphragm	2	●240672 (HY)	■240672 (HY)
29	Outer diaphragm plate	2	240768 (PP)	240768 (PP)
30	Outer chamber	2	240770 (PP)	240770 (PP)
31	O-ring	4	●241000 (BN)	■240772 (TF)
32	Ball valve seat	4	240773 (PP)	©240773 (PP)
33	Check valve ball	4	●240678 (HY)	■240677 (TF)
34	Discharge elbow	2	240775 (PP)	240775 (PP)
35	Suction elbow	2	240777 (PP)	240777 (PP)
36	Manifold	2	243102 (PP)	243102 (PP)
37	Self-tapping screw	8	240781	240781
38	Hex head capscrew	6	240782	240782
39	Flat washer	12	240783	240783
40	O-ring	4	●241001 (BN)	■240784 (TF)

© Indicates change (BN) Buna-N, (HY) Hytrel, (PP) Polypropylene, (TF) Teflon

In freezing temperatures the pump must be completely drained when idle. This model must be tilted to allow the liquid from the chambers to run out of the discharge port.

SERVICE INSTRUCTIONS: TROUBLESHOOTING

1. Pump will not cycle

- A. Check to make sure the unit has enough pressure to operate and that the air inlet valve is open.
- B. Check the discharge line to insure that the discharge line is neither closed nor blocked.
- C. If the spool in the air distribution valve is not shifting, check the main spool. It must slide freely.

- D. Excessive air leakage in the pump can prevent cycling. This condition will be evident Air leakage into the discharge line indicates a ruptured diaphragm. Air leakage from the exhaust port indicates leakage in the air distribution valve. See further service instructions.
- E. Blockage in the liquid chamber can impede movement of diaphragm.

2. Pump cycles but will not pump

- A. Suction side of pump pulling in air. Check the suction line for air leaks and be sure that the end of the suction line is submerged. Check flange bolting. Check valve flanges and manifold to chamber flange joints.

- B. Make certain the suction line or strainer is not plugged. Restriction at the suction is indicated by a high vacuum reading when a vacuum gauge is installed in the suction line.
- C. Check valves may not be seating properly. To check remove the suction line and cover the suction port with your hand. If the unit does not pull a good suction (vacuum), the check valves should be inspected for proper seating
- D. Static suction lift may be too high. Priming can be improved by elevating the suction and discharge lines higher than the check valves and pouring liquid into the unit through the suction inlet. When

priming at high suction lifts or with long suction lines operate the pump at maximum cycle rate.

sealing. If pump is to prime properly, valves must seat air tight.

remove any irregular marks on the surfaces. When the spool slides freely on the sleeve, coat the parts with light oil and reassemble. The four capscrews inserted through the valve body cap to hold the air valve to the intermediate section should be torqued to 90 in./lbs. (1 1.1 6 kilograms/meter).

3. Low performance

- A. Capacity is reduced as the discharge pressure increases, as indicated on the performance curve. Performance capability varies with available inlet air supply. Check air pressure at the pump inlet when the pump is operating to make certain that adequate air supply is maintained.
- B. Check vacuum at the pump suction. Capacity is reduced as vacuum increases. Reduced flow rate due to starved suction will be evident when cycle rate can be varied without change in capacity. This condition will be more prevalent when pumping viscous liquids. When pumping thick, heavy materials the suction line must be kept as large in diameter and as short as possible, to keep suction loss minimal.
- C. Low flow rate and slow cycling rate indicate restricted flow through the discharge line. Low flow rate and fast cycling rate indicate restriction in suction line or air leakage into suction.
- D. Unstable cycling indicates improper check valve seating on one chamber. This condition is confirmed when unstable cycling repeats consistently on alternate exhausts. Cycling that is not consistently unstable may indicate partial exhaust restriction due to freezing and thawing of exhaust air. Use of an anti-freeze lubricant in an air line lubricator should solve this problem.

DIAPHRAGM SERVICING

Remove the twelve capscrews securing the manifold assemblies to the outer chambers. Remove the two V-Band clamps securing the outer chambers to the intermediate housing. Remove the diaphragm assembly(outer plate, diaphragm, inner plate) by turning the assembly counterclockwise using a 3/4" (1.91 cm) wrench on the outer plate lugs. (If a socket is used, it must be a six point socket.) The interior components consisting of the shaft seal and pilot valve assembly are now accessible for service.

Procedures for reassembling the diaphragms are the reverse of the above. During reassembly make certain that the rubber bumper is on the rod on each side. Install the diaphragm with the natural bulge outward.

Install the outer diaphragm plate on the outside of the diaphragm and make certain that the large radius side of the inner plate is toward the diaphragm. Tighten the outer diaphragm plate to approximately 70 in. lbs.

Torque while allowing the diaphragm to turn freely with plates. Use a wrench on the outer diaphragm plate of the opposite side to keep rod from rotating. If the opposite chamber is assembled, the rod need not be held.

AIR DISTRIBUTION VALVE SERVICING

The spool and sleeve are rust and corrosion resistant brass and hardened stainless steel. The spool is closely sized to the sleeve and should slide -freely. Accumulation of dirt and oils may prevent the pump from cycling. Remove the valve body from the center pump housing, remove the end caps, and push the spool out of the sleeve. Wash the parts in cleaning solvent or kerosene, and check the spool and sleeve for possible roughness, nicks or scratches. Use a fine stone or crocus cloth to carefully

PILOT VALVE ACTUATOR

The pilot valve spool contains 6 o-rings. This spool moves through the sleeve. Check condition of o-rings for cuts or gouges before re-assembly. Apply a light coating of grease to the o-rings when inserting into the sleeve. Insert spool into sleeve from chamfered side. The o-ring on the end should be installed after the spool is in place (install last). Make sure the sleeve is locked into the intermediate bracket (item 16) with retainer ring.

A Note about Air Valve Lubrication

The Lincoln pump's pilot valve and main air valve assemblies are designed to operate WITHOUT lubrication. This is the preferred mode of operation. There may be instances of personal preference, or poor quality air supplies when lubrication of the compressed air supply is required. The pump air system will operate with properly lubricated compressed air supplies. Proper lubrication of the compressed air supply would entail the use of an air line lubricator (available from Lincoln) set to deliver one drop of 10 wt., non-detergent oil for every 20 SCFM of air the pump consumed at its point of operation. Consult the pump's published Performance Curve to determine this.

It is important to remember to inspect the sleeve and spool set routinely. It should move back and forth freely. This is most important when the air supply is lubricated. If a lubricator is used, oil accumulation will, overtime, collect any debris from the compressed air. This can prevent the pump from operating properly.

CHECK VALVE SERVICING

Need for inspection or service is usually indicated by poor priming, unstable cycling, reduced performance or the pump's cycling but not pumping.

Remove the twelve capscrews securing the manifold assemblies to the outer chambers. Inspect the surfaces of both check valve and seat for wear or damage that could prevent proper

RETAIN THIS INFORMATION FOR FUTURE REFERENCE

When ordering replacement parts, list: Part Number, Description, Model Number and Series Letter. LINCOLN provides a Distributor Network that stocks equipment and replacement parts.