

**OPERATING INSTRUCTIONS, SERVICE MANUAL  
AND REPAIR PARTS LIST**

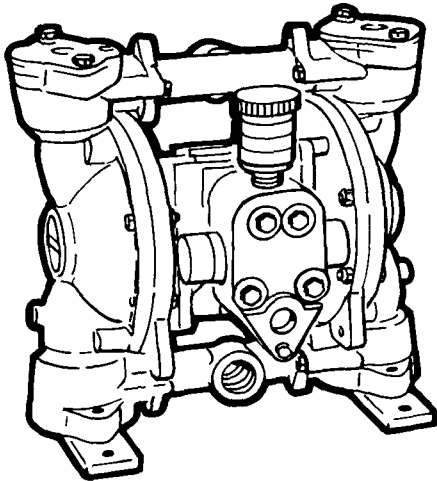

**OPERATING AND  
SERVICE INSTRUCTIONS**

**! WARNING**

**HAZARD WARNING  
POSSIBLE EXPLOSION**

**HAZARD** can result if 1, 1, 1, -Trichloroethane, Methylene Chloride or other Halogenated Hydrocarbon solvents are used in pressurized fluid systems having Aluminum or Galvanized wetted parts. Death, serious bodily injury and/or property damage could result. Consult with the factory if you have questions concerning Halogenated Hydrocarbon solvents.

**! WARNING**

**Do not use for pumping flammable materials. Build up and discharge of static electricity may result in a fire and/or explosion causing personal injury and loss to property.**

**Principle of Operation**

The pump is powered by compressed air which alternately pressurizes the inner sides of the two diaphragm chambers while simultaneously exhausting

the opposite inner chambers causing the diaphragms, which are connected by a shaft, to move endwise. Since air pressure is applied over the entire surface of the diaphragm which is forcing liquid to be discharged by its other side, the diaphragm is operating under a balanced condition during the discharge stroke. This allows the unit to be operated at discharge heads over 200 feet (61 meters) of water head.

Alternate pressurizing and exhausting of the diaphragm chamber is performed by an externally mounted, pilot-operated, four way, spool type air distribution valve. When the spool is at one end of the valve body, inlet air pressure is connected to one diaphragm chamber and the other diaphragm chamber is connected to the exhaust. When the spool is moved to the opposite end of the valve body, the porting of chambers is reversed. The air distribution valve spool is moved from one end position to the other in the valve body by means of an internal pilot valve which alternately pressurizes the ends of the air distribution valve spool while simultaneously exhausting the other ends. The pilot valve is positively shifted at each end of the diaphragm stroke by the diaphragm plate's coming in contact with the end of the pilot valve spool and pushing it into position for shifting of the air distribution valve. The chambers are manifolded together with a suction and discharge check valve for each chamber to maintain flow in one direction through the pump.

**INSTALLATION  
PROCEDURES**

Position the pump as close as possible to the source of the liquid to be pumped. Avoid long or undersize suction lines and use the minimum number of fittings.

For permanent installation involving rigid piping, install short flexible sections of hose between the pump and piping. This reduces strains and permits easier removal of the pump for service when required. **At time of installation, inspect all external gasketed fasteners for looseness caused by**

**gasket creep. Tighten loose fittings securely to prevent leakage.**

**AIR SUPPLY**

Do not connect the unit to an air supply in excess of 125 PSI (8.61 bars). Install a shutoff valve in the air supply line to permit removal of the unit for servicing. When connecting an air supply of rigid piping, mount a section of flexible line to the pump to eliminate piping strain. In permanent installations, an air line filter is recommended. **The weight of the air supply line and of the filter must be supported by some means other than the air valve cap. Failure to provide support may result in damage to the pump. A pressure regulating valve should be installed to prevent pressure from exceeding recommended limits.**

**LUBRICATION**

A small amount of lightweight oil (SAE 10 wt. maximum) poured into the air inlet daily is recommended to lubricate the air distribution valve. An air line filter and lubricator is recommended on permanent installations. The lubricator should be set at a rate of one drop of oil for every 20 SCFM (Standard Cubic Feet per Minute) (9.44 lit./sec.) of air being used. When using EPDM elastomers, use no oil in the system or chemical attack may occur. Consult factory for oil recommendation.

**OPERATION**

Your pump has been tested prior to shipment and is ready for use as received. It is completely self-priming and no initial filling with fluid is required.

If the unit is to be totally submerged, the air exhaust must be piped above liquid level to prevent the liquid and foreign material from entering the air distribution valve mechanism.

Open the inlet air valve at least one turn to allow sufficient cycling rate for the pump to prime (30 to 60 cycles per minute). After pumping starts, adjust the inlet air valve for the desired pumping capacity. When further opening of

the inlet air valve increases cycling rate without increasing the flow rate, the pump is being starved of liquid due to suction limitations. Further opening of the air inlet valve will waste compressed air. Set the inlet air valve for lowest cycling rate that does not decrease flow rate for most efficient operation.

### FREEZING OR ICING OF EXHAUST

Icing of the air exhaust can occur under certain conditions of temperature and humidity on compressed air power equipment. When pump performance suffers because of icing, a non-sticky anti-freeze lubricant such as KILFROST, in an air line lubricator, will solve the problem. Icing is more likely to occur at high discharge pressures.



### CAUTION

If a diaphragm fails, the pumped product or fumes can enter the air side of the pump. This side is exhausted through the exhaust port (muffler).

When the product is a hazardous or toxic material, the exhaust should be piped to an appropriate area for safe disposition.

When the product source is at a higher level than the pump (flooded suction), the exhaust should be piped to a higher level than the product to prevent spills caused by siphoning.

### MAINTENANCE AFTER USE



### CAUTION

Before maintenance or repair, shut off the compressed air line, bleed the pressure, and disconnect the air line from the pump. The discharge line may be pressurized and must be bled of its pressure. When the pump is used for toxic or aggressive fluids, it should be flushed clean prior to disassembly.

When the pump is used for materials that tend to settle out or transform from liquid to solid form, care must be taken after each use or during idle time to remove them and flush the pump as required to prevent damage.

In freezing temperatures the pump must be completely drained when idle. This model must be tilted to allow the liquid from the chambers to run out of the discharge port.

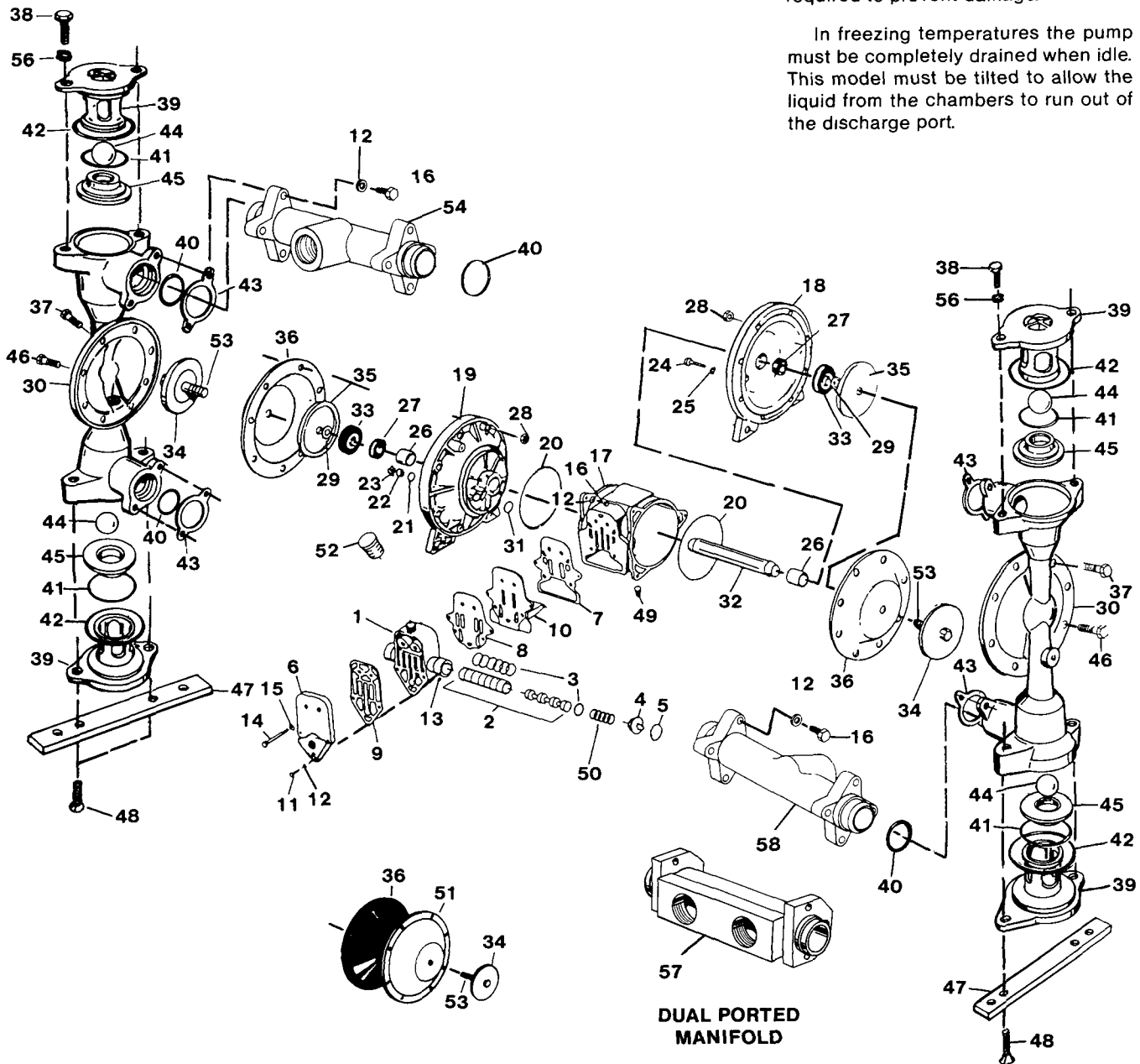

## SERVICE INSTRUCTIONS: TROUBLESHOOTING

### 1. Pump will not cycle

- A. Check to make sure the unit has enough pressure to operate and that the air inlet valve is open.
- B. Check the discharge line to insure that the discharge line is neither closed nor blocked.
- C. If the spool in the air distribution valve is not shifting, check the main spool. It must slide freely.
- D. Excessive air leakage in the pump can prevent cycling. This condition will be evident. Air leakage into the discharge line indicates a ruptured diaphragm. Air leakage from the exhaust port indicates leakage in the air distribution valve. See further service instructions.
- E. Blockage in the liquid chamber can impede movement of diaphragm.

### 2. Pump cycles but will not pump

- A. Suction side of pump pulling in air. Check the suction line for air leaks and be sure that the end of the suction line is submerged. Check flange bolting. Check valve flanges and manifold to chamber flange joints.
- B. Make certain the suction line or strainer is not plugged. Restriction at the suction is indicated by a high vacuum reading when a vacuum gauge is installed in the suction line.
- C. Check valves may not be seating properly. To check, remove the suction line and cover the suction port with your hand. If the unit does not pull a good suction (vacuum), the check valves should be inspected for proper seating.
- D. Static suction lift may be too high. Priming can be improved by elevating the suction and discharge lines higher than the check valves and pouring liquid into the unit through the suction inlet. When priming at high suction lifts or with long suction lines operate the pump at maximum cycle rate.

### 3. Low performance

- A. Capacity is reduced as the discharge pressure increases, as indicated on the performance curve. Performance capability varies with available inlet air supply. Check air pressure at the pump inlet when the pump is operating to make certain that adequate air supply is maintained.
- B. Check vacuum at the pump suction. Capacity is reduced as vacuum increases. Reduced flow rate due to starved suction will be evident when cycle rate can be varied without change in capacity. This condition

## REPAIR KITS AVAILABLE

† 86252 Air End Repair Kit - All Models.

● 86244 Hytrel Wet End Repair Kit - Models 84852 & 84856.

★ 86245 Teflon Wet End Repair Kit - Model 84853.

■ 86237 Buna-N Wet End Repair Kit - Model 84855.

## SERVICE PARTS

Item No.	Description	Qty.	Part Number			
			Model 84852	Model 84853	Model 84855	Model 84856
1	Body, spool valve	1	240695	240695	240695	240695
2	Sleeve & spool set	1	† 240696	† 240696	† 240696	† 240696
3	O-ring	8	† 240697 (BN)	† 240697 (BN)	† 240697 (BN)	† 240697 (BN)
4	Cap, end	2	240698	240698	240698	240698
5	Ring, retainer	2	† 240699	† 240699	† 240699	† 240699
6	Cap, valve body	1	240700	240700	240700	240700
7	Gasket	1	† N/A (BN)	† N/A (BN)	† N/A (BN)	† N/A (BN)
8	Gasket	1	† N/A (BN)	† N/A (BN)	† N/A (BN)	† N/A (BN)
9	Gasket	1	† N/A (BN)	† N/A (BN)	† N/A (BN)	† N/A (BN)
10	Pilot valve assembly	1	† N/A	† N/A	† N/A	† N/A
11	Capscrew, hex head	1	240705	240705	240705	240705
12	Washer, flat	15	240706	240706	240706	240706
13	Nut, square	1	240707	240707	240707	240707
14	Capscrew, hex head	4	240708	240708	243563	240708
15	Washer, flat	4	240709	240709	240709	240709
16	Capscrew, hex head	14	240710	240710	240710	240710
17	Bracket, intermediate	1	240711	240711	240711	240711
18	Chamber, diaphragm	1	240712	240712	240712	240712
19	Chamber, diaphragm	1	240713	240713	240713	240713
20	O-ring	2	240714 (BN)	240714 (BN)	240714 (BN)	240714 (BN)
21	O-ring	2	† 240655 (BN)	† 240655 (BN)	† 240655 (BN)	† 240655 (BN)
22	Bushing	2	† 240716	† 240716	† 240716	† 240716
23	Ring, retainer	2	† 240717	† 240717	† 240717	† 240717
24	Plunger, actuator	2	† N/A	† N/A	† N/A	† N/A
25	Bumper	2	† N/A	† N/A	† N/A	† N/A
26	Bearing, sleeve	2	240720	240720	240720	240720
27	Seal, u-cup	2	† 240721 (NI)	† 240721 (NI)	† 240721 (NI)	† 240721 (NI)
28	Nut, hex	8	240722	240722	240722	240722
29	Washer, sealing	2	240723	240723	240723	240723
30	Chamber, outer	2	240724	240724	240724	240724
31	Ring, sealing	2	240725	240725	240725	240725
32	Rod, diaphragm	1	240726	240726	240726	240726
33	Bumper	2	240727	240727	240727	240727
34	Plate, outer diaphragm	2	240728	240728	240728	240728
35	Plate, inner diaphragm	2	240729	240729	240729	240729
36	Diaphragm	2	● 240730 (HY)	★ 240730 (HY)	■ N/A (BN)	● 240730 (HY)
37	Capscrew, hex head	8	240731	240731	240731	240731
38	Capscrew, hex head	4	240732	240732	243564	240732
39	Ball retainer/cap	4	240733	240733	240733	240733
40	O-ring	4	● 244191 (BN)	★ 240735 (TF)	■ N/A (BN)	● 244191 (BN)
41	O-ring	4	● 244192 (BN)	★ 240737 (TF)	■ N/A (BN)	● 244192 (BN)
42	O-ring	4	● 244193 (BN)	★ 240739 (TF)	■ N/A (BN)	● 244193 (BN)
43	Spacer, ring	4	-----	★ 240740	-----	-----
44	Ball, check valve	4	● 240741 (HY)	★ 240742 (TF)	■ N/A (BN)	● 240741 (HY)
45	Seat, check valve	4	240743	240743	240743	240743
46	Capscrew, hex head	8	240744	240744	240744	240744
47	Foot, mounting	2	240745	240745	240745	240745
48	Capscrew, flat head	4	240746	240746	240746	240746
49	Pipe plug	1	240747	240747	240747	240747
50	Spring	1	† 240748	† 240748	† 240748	† 240748
51	Diaphragm, overlay	2	-----	★ 240749 (TF)	-----	-----
52	Muffler	1	240750	240750	240750	240750
53	Stud	2	240751	240751	240751	240751
54	Manifold	1	240752	240752	240752	240752
55	Washer, flat (not shown)	4	240753	240753	240753	240753
56	Washer, flat	4	240709	240709	240709	243566
57	Manifold (Dual)	1	-----	-----	-----	243565
58	Manifold	1	240752	240752	240752	-----

N/A - Not Available as a separate item (see symbol for Repair Kit).

(NI) Fluorinated Nitrile, (TF) Teflon, (HY) Hytrel, (BN) Buna-N

will be more prevalent when pumping viscous liquids. When pumping thick, heavy materials the suction line must be kept as large in diameter and as short as possible, to keep suction loss minimal.

- C. Low flow rate and slow cycling rate indicate restricted flow through the discharge line. Low flow rate and fast cycling rate indicate restriction in suction line or air leakage into suction.
- D. Unstable cycling indicates improper check valve seating on one chamber. This condition is confirmed when unstable cycling repeats consistently on alternate exhausts. Cycling that is not consistently unstable may indicate partial exhaust restriction due to freezing and thawing of exhaust air. Use of an anti-freeze lubricant in an air line lubricator should solve this problem.

## CHECK VALVE SERVICING



### CAUTION

**Whether removing capscrews on suction or discharge valve retainer/cap, make sure all pressure on suction and discharge side of pump has been relieved. Re-lock wire the capscrews before continuing use.**

Need for inspection or service is usually indicated by poor priming, unstable cycling, reduced performance or the pump's cycling but not pumping.

Inspect the surfaces of both check valve and seat for wear or damage that could prevent proper sealing. If pump is to prime properly, valves must seat air tight.

## DIAPHRAGM SERVICING

Remove the eight nuts securing the outer diaphragm chamber flange and remove the chamber. Loosen the capscrew securing the diaphragm and plate to the rod by leaving the diaphragm engaged with the capscrews around the outer flange, preventing rotation of the rod. **DO NOT USE A WRENCH ON THE DIAPHRAGM ROD. FLAWS ON THE SURFACE MAY DAMAGE BEARINGS AND SEAL.**

During reassembly make certain that the rubber bumper is on the rod on each side. Install the diaphragm with the natural bulge outward as indicated on the diaphragm. Install the heavier plate on the outside of the diaphragm and make certain that the large radius side of both plates are toward the diaphragm. Place the sealing washer between the inner diaphragm plate and the end of the rod. Tighten the capscrew to approximately 25 ft. lbs. (3.456 kilograms/meters). Torque while allowing the diaphragm to turn freely with plates. Use a wrench on the capscrew of the opposite side to keep rod from rotating. If the opposite chamber is assembled, the rod need not be held.

When reassembling the outer chambers and the manifold, the bolts securing the manifold flange to the chamber should be snugged prior to tightening the chamber bolts, to insure that the chamber port flange is square with the manifold flange. Finish tightening the manifold flange bolts after chamber bolting is secured.

## AIR DISTRIBUTION VALVE SERVICING

The spool and sleeve are rust and corrosion resistant brass and hardened stainless steel. The spool is closely sized to the sleeve and should slide freely. Accumulation of dirt and oils may prevent the pump from cycling. Remove the valve body from the center pump housing, remove the end caps, and push the spool out of the sleeve. Wash the parts in cleaning solvent or kerosene, and check the spool and sleeve for possible roughness, nicks or scratches. Use a fine stone or crocus cloth to carefully remove any irregular marks on the surfaces. When the spool slides freely on the sleeve, coat the parts with light oil and reassemble. The four capscrews inserted through the valve body cap to hold the air valve to the intermediate section should be torqued to 150 in./lbs. (1.728 kilograms/meter).

## PILOT VALVE SERVICING

This assembly is reached by removing the air distribution valve body from the pump and lifting the pilot valve out of the intermediate housing.

Upon reassembly of this section caution must be taken to prevent damage to the actuator plungers and bushings. Before inserting the pilot valve into the intermediate bracket you must first be certain that the plungers are at their most outward position. This is done by inserting your index finger through the valve body opening into the intermediate bracket and pushing the plungers towards the outer chambers of the pump. It may be necessary to center the spool of the pilot valve to assure clearance and prevent overlapping the plungers with the pilot valve spool.

## PILOT VALVE ACTUATOR SERVICING

The plungers may be removed for inspection or replacement from the inside by removing the air distribution valve body and the pilot valve body from the pump. The plungers should be visible as you look into the intermediate from the top. Depending on their position you may find it necessary to use a fine piece of wire to pull them out.

The bushings for the pilot valve actuators set in a recessed area of the non wetted chambers and are held in place by a star-lock retaining ring. Beneath the bushing is the o-ring seal which prevents the pressurized air from escaping out of the chamber during a discharge stroke of the pump. Under rare circumstances, it may become necessary to replace the o-ring seal. This can be done by removing the wetted chamber and diaphragm assembly, prying out the star-lock retaining ring and lifting the bushing out of position. The star-lock retaining ring is a one time use item, normally replaced with a new one each time it is removed.

### RETAIN THIS INFORMATION FOR FUTURE REFERENCE

When ordering replacement parts, list: Part Number, Description, Model Number, and Series Letter.

LINCOLN provides a Distributor Network that stocks equipment and replacement parts.