

**OPERATING INSTRUCTIONS, SERVICE MANUAL
AND REPAIR PARTS LIST**

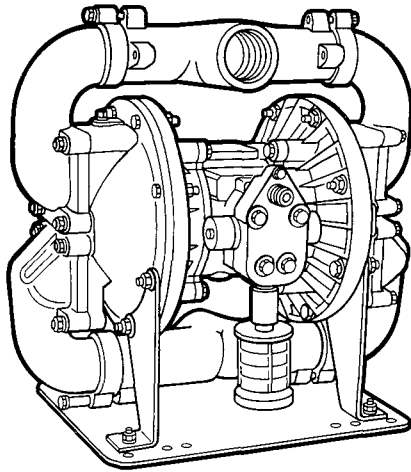

**OPERATING AND
SERVICE INSTRUCTIONS**

WARNING

**HAZARD WARNING
POSSIBLE EXPLOSION**

HAZARD can result if 1, 1, 1, - Trichloroethane, Methylene Chloride or other Halogenated Hydrocarbon solvents are used in pressurized fluid systems having Aluminum or Galvanized wetted parts. Death, serious bodily injury and/or property damage could result. Consult with the factory if you have questions concerning Halogenated Hydrocarbon solvents.

WARNING

Do not use for pumping flammable materials. Build up and discharge of static electricity may result in a fire and/or explosion causing personal injury and loss to property.

Principle of Operation

This pump is powered by compressed air which alternately pressurizes the inner side of one diaphragm chamber while simultaneously exhausting the other inner chamber causing the diaphragms, which are connected by a

shaft, to move endwise. Since air pressure is applied over the entire surface of the diaphragm which is forcing liquid to be discharged from opposite side, the diaphragm is operating under a balanced condition during the discharge stroke and allows the unit to be operated at discharge heads over 200 feet (61 meters) of water head.

Since the diaphragms are connected by a shaft secured by plates to the center of the diaphragms, one diaphragm is being pressurized to perform the discharge stroke while the other diaphragm is being pulled to perform the suction stroke in the opposite chamber. The suction stroke becomes the only unbalanced load applied to diaphragms during operation, providing much longer life than mechanical operated diaphragms under similar conditions. Since the suction lift portion of the operation is essentially the only load applied to diaphragms, the longest possible diaphragm life will be attained by the least amount of suction lift. ALWAYS KEEP THE UNIT AS CLOSE TO THE LIQUID BEING PUMPED AS POSSIBLE. POSITIVE SUCTION HEAD IN EXCESS OF 10 FEET (3.048 METERS) OF LIQUID SHOULD ALSO BE AVOIDED FOR GOOD DIAPHRAGM SERVICE LIFE.

Alternate pressurizing and exhausting of the diaphragm chamber is performed by means of an externally mounted, pilot-operated, four way, spool type, air distribution valve. When the spool is at one end of the valve body, inlet air pressure is connected to one diaphragm chamber and the other diaphragm chamber is connected to the exhaust. When the spool is removed to the opposite end of the valve body, the porting of chambers is reversed. The air distribution valve spool is moved from one end position to the other in the valve body by means of an internal pilot valve which alternately pressurizes the ends of the air distribution valve spool while simultaneously exhausting the other. The pilot valve is positively shifted at each end of the diaphragm stroke by the diaphragm plate coming in contact with the end of the pilot valve spool and pushing it into position for shifting of the air distribution valve. The chambers are

manifolded together with a suction and discharge check valve for each chamber to maintain flow in one direction through the pump.

**INSTALLATION
PROCEDURES**

Locate the pump as close to product to be pumped as is practical, to keep length of suction line and number of fittings to a minimum. DO NOT REDUCE LINE SIZE except for very low flow rates or where higher velocities are required to keep pumped material in suspension in the carrying liquid. For installations involving the use of rigid piping, short flexible sections of hose are recommended between pump and piping. This reduces piping strains and vibrations.

BEFORE PUMP OPERATION

All external gasket fasteners must be inspected for looseness caused by gasket creep after leaving the factory. Retorque loose fasteners to insure against leakage. Follow recommended torques where called out (A card is attached to each new pump stating this fact).

AIR SUPPLY

Do not connect the unit to air supply in excess of 125 PSI (8.61 bars). Connect the pump air inlet to air supply in of sufficient capacity and pressure as required for desired performance. When air supply line is solid piping, use a short length of flexible hose between pump and piping to eliminate piping strains.

LUBRICATION

A small amount of lightweight oil (SAE 10 wt max) poured into air inlet daily is desirable to provide lubrication for air distribution valve. An air line filter and lubricator is recommended on permanent installations. Set at a rate of 1 drop of oil for every 20 SCF (Standard Cubic Feet) (9.4386 lit/sec) of air being used. When using EPDM RUBBER (diaphragms and ball valves) eliminate the use of all oil in the system, chemical attack may otherwise occur.

INLET AIR VALVE SETTING

Make certain that the capacity at which the pump is operating is not limited by the suction conditions involved. Keep in mind that the diaphragms will move at a rate proportional to inlet air flow. If the cycling rate is allowed to exceed the rate that liquid can enter the chamber that is on the suction stroke, the liquid is simply pulled apart (cavitation) and displacement is reduced. For the most

efficient use of compressed air and longest diaphragm life, always throttle the air inlet to lowest cycling rate that does not decrease flow rate.

Start the unit by opening air valve approximately 1/2 to 3/4 turn. After the unit starts pumping, the air valve can be opened to increase pumping capacity as desired. When further opening of the valve increases cycling rate without increase in capacity, cavitation exists; and valve should be closed slightly.

FREEZING OR ICING OF EXHAUST

Icing of air exhaust can be experienced under certain temperature and humidity condition on all compressed air powered equipment. When pump performance suffers because of icing, a non-sticky anti-freeze lubricant such as KILFROST, in an air line lubricator, will solve the problem. Icing is more likely to occur at high discharge pressures.

AIR EXHAUST

The pumps can be submerged if the materials of construction are compatible with the liquid and the exhaust is piped above the liquid level. Piping used for the exhaust should not be smaller than 1" (2.54 cm) pipe size. Reduced pipe size can restrict the exhausted air and cause reduced pump performance.

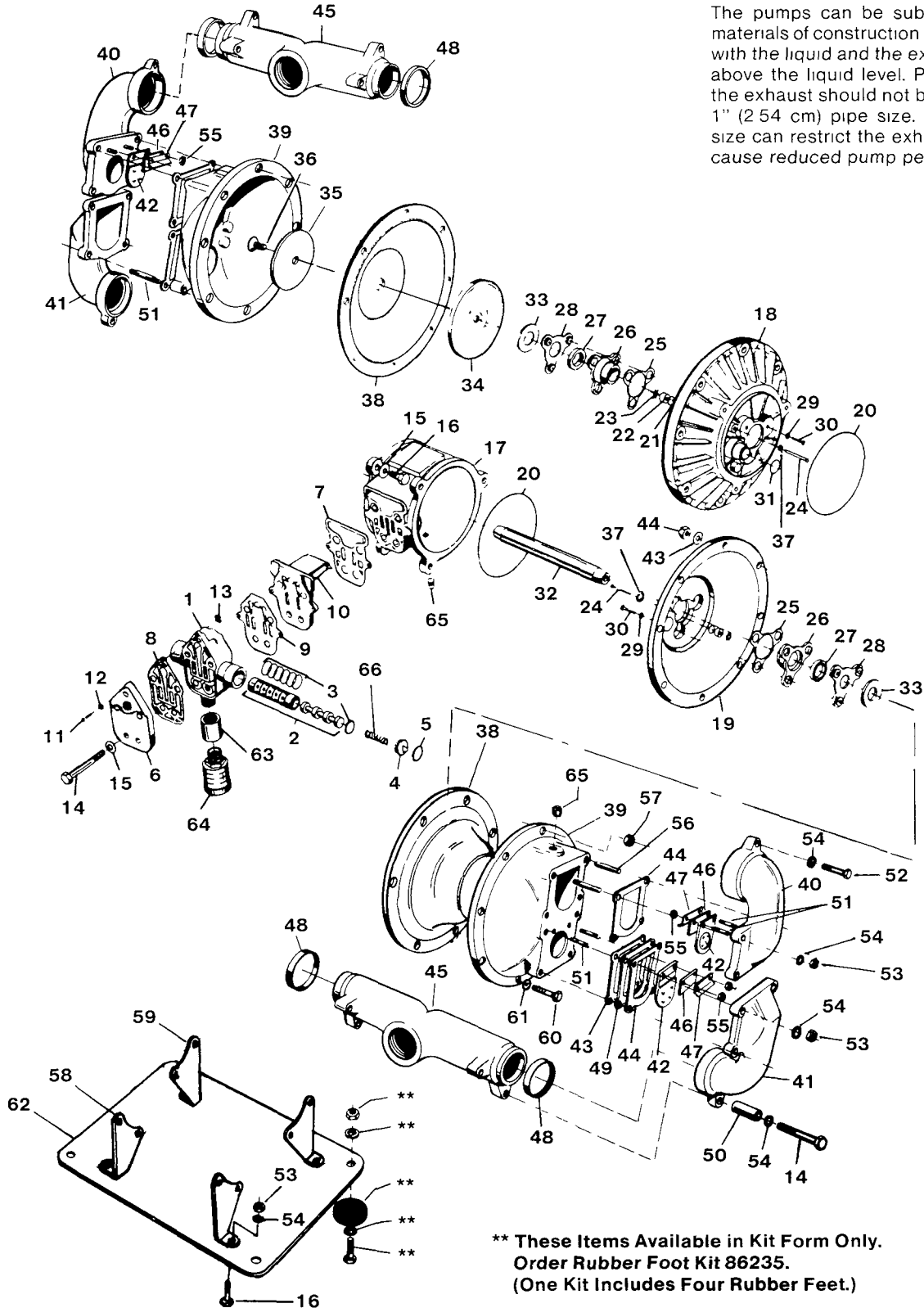

** These Items Available in Kit Form Only.
 Order Rubber Foot Kit 86235.
 (One Kit Includes Four Rubber Feet.)



CAUTION

If a diaphragm fails, the pumped product or fumes can enter the air side of the pump. This side is exhausted through the exhaust port (muffler).

When the product is a hazardous or toxic material, the exhaust should be piped to an appropriate area for safe disposition.

When the product source is at a higher level than the pump (flooded suction), the exhaust should be piped to a higher level than the product to prevent spills caused by siphoning.

MAINTENANCE AFTER USE

When the pump is used for materials that tend to settle out or transform from liquid to solid form, care must be taken after each use or during idle time to remove them and flush the pump as required to prevent damage.

In freezing temperatures the pump must be completely drained when idle. This model must be tilted to allow the liquid from the chambers to run out of the discharge port.



CAUTION

Before maintenance or repair, shut off the compressed air line, bleed the pressure, and disconnect the air line from the pump. The discharge line may be pressurized and must be bled of its pressure. When the pump is used for toxic or aggressive fluids, it should be flushed clean prior to disassembly.

SERVICE INSTRUCTIONS: TROUBLE SHOOTING

PROBLEM:

Pump cycles but will not pump (Note. Higher suction lifts require fast cycling speed for priming.)

POSSIBLE CAUSES:

- A Air leak in suction line.
- B Excessive suction lift
- C Check valve not seating properly.
- D Leakage at joint of suction manifold or elbow flange.
- E Suction line or strainer plugged
- F Diaphragm ruptured.

PROBLEM:

Pump will not cycle (Note Always disconnect air supply to relieve air pressure before disassembling any portion of pump)

POSSIBLE CAUSES:

- A Discharge hose or line plugged, or discharge head requirement greater than air supply pressure (Disconnect discharge line to check.)
- B Spool in air distribution valve not shifting. (Remove end cap and check spool - must slide freely)
- C Diaphragm ruptured (Air will escape out discharge line in this case)
- D Blockage in diaphragm chamber preventing movement (Shut off air supply and reopen after pressure is relieved)

PROBLEM:

Uneven discharge flow (Indicates one chamber not operating properly)

POSSIBLE CAUSES:

- A Check valve not sealing properly in one chamber
- B Diaphragm failure in one chamber
- C Air leak at suction manifold joint or elbow flange one side

SERVICE PARTS

Item	Description	Qty.	Part	Item	Description	Qty.	Part
1	Body, spool valve	1	240695 (PP)	34	Plate, inner diaphragm	2	240898 (AL)
2	Sleeve & spool set	1	240795	35	Plate, outer diaphragm	2	243136
3	O-ring	8	240697 (BN)	36	Capscrew, flat head socket	2	243137
4	Cap, end	2	240698 (HY)	37	Bumper	2	*
5	Ring, retaining	2	240699 (SS)	38	Diaphragm	2	240899 (BN)
6	Cap, valve body	1	240978 (AL)	39	Chamber, outer	2	243138 (AL)
7	Gasket	1	*	40	Elbow, suction	2	243139 (AL)
8	Gasket	1	*	41	Elbow, discharge	2	243140 (AL)
9	Gasket	1	*	42	Flap valve	4	243141 (BN)
10	Assembly, pilot valve	1	242005	43	Gasket, seat	4	243142
11	Capscrew, hex head	1	240979	44	Gasket, flange	4	243143
12	Washer, flat	1	240706	45	Manifold, discharge, suction	2	243144 (AL)
13	Nut, square	1	240980	46	Pad, hinge - flap valve	4	243145 (BN)
14	Capscrew, hex head	6	240708	47	Retainer, flap valve	4	243147 (SS)
15	Washer, flat	10	240709	48	Ring, sealing	4	243148 (BN)
16	Capscrew, hex head	10	240889	49	Seat, flap valve	4	243149 (SS)
17	Bracket, intermediate	1	240788 (PP)	50	Spacer	2	243150
18	Chamber, inner	1	240890 (PP)	51	Stud	8	243151 (SS)
19	Chamber, inner	1	240891 (PP)	52	Capscrew, hex head	2	243152
20	O-ring	2	240791 (BN)	53	Nut, hex	20	240722
21	O-ring	2	240655 (BN)	54	Washer, lock	24	243153
22	Bushing	2	240716	55	Nut, stop	8	243154 (SS)
23	Ring, retainer	2	240717 (SS)	56	Stud	16	243155
24	Plunger, actuator	2	*	57	Nut, hex	16	240911
25	Gasket, bearing	2	240845 (BN)	58	Mounting foot, left hand	2	243156
26	Bearing, sleeve	2	240893	59	Mounting foot, right hand	2	243157
27	Seal, U-cup	2	243134 (BN)	60	Capscrew, hex head	16	240909
28	Retainer, bearing	2	240805 (PP)	61	Washer, flat	16	240918
29	Washer, flat	6	240692	62	Plate, base	1	243158 (AL)
30	Screw, self-tapping	6	240663 (SS)	63	Elbow, pipe	1	240865
31	Ring, sealing	2	240802 (BN)	64	Muffler	1	240836
32	Rod, diaphragm	1	240895 (SS)	65	Pipe plug	3	240747
33	Bumper	2	240809	66	Spring	1	240748

(AL) Aluminum, (BN) Buna-N, (HY) Hytrel, (PP) Polypropylene, (SS) Stainless Steel

* Can only be purchased in Kit 86236.

REPAIR INSTRUCTIONS

This pump is built for long maintenance-free operation; however, each installation is different, and ideal conditions cannot always be maintained. There are several areas for which it is felt necessary to detail the disassembly and reassembly procedure.

DISASSEMBLY

1. Check Valve:

Valve inspection requires removal of (4) 3/8" hex nuts. On the suction side the flange, when removed, carries the valve and seat as an assembly. On the discharge side, the valve and seat will stay with the diaphragm housing. Visual inspection and cleaning is possible. If parts are to be replaced, remove the self locking nuts and all parts are accessible.

2. Diaphragm Assembly:

Diaphragms can be inspected or the diaphragm assembly removed without removing the suction and discharge flanges. Remove (8) nuts around the chamber flange, and the housing assembly will pull off. Check valves can be inspected for proper seating at this point as well as the diaphragm. Use care to keep foreign matter from behind the diaphragm. The opposite diaphragm may be inspected by the same procedure. If either diaphragm has to be replaced, follow closely these steps:

Pull the outer diameter of one diaphragm off the (8) capscrews. NOTE: One side only! On the free diaphragm assembly, use a 3/8" allen wrench to turn the assembly (diaphragm, plates and screw) loose from the shaft. Once the assembly has turned, it will turn out by hand by use of the diaphragm. Now the opposite diaphragm assembly and the drive shaft will pull free from the capscrews and pump intermediate assembly. The interior components consisting of sleeve bearings, rod seals, and pilot valve actuator bushings are now accessible for service if required. Hold the shaft in a clamping device making sure to protect surface of shaft so as not to scratch or mar it in any way. The diaphragm assembly will turn loose. To disassemble the components, turn a 10-32 screw by hand into the tapped hole in the inner plate. This keeps the plate from turning while the socket head capscrew is removed. To do this, place assembly in a vise so the two protruding ends of screws are loose in the vise jaws (3/4" apart). Turn the center screw loose from the back plate and the assembly will come apart.

3. Air Distribution Valve:

The spool and sleeve are rust and corrosion resistant brass and hardened stainless steel. The spool is closely sized to the sleeve and should slide freely. Accumulation of dirt and oils may prevent the pump from cycling. Remove the valve body from the center pump housing, remove the end caps, and push the spool out of the sleeve. Wash the parts in cleaning solvent or kerosene, and check the spool and sleeve for possible roughness, nicks, or scratches. Use a fine stone or crocus cloth to carefully remove any irregular marks on the surfaces. When the spool slides freely on the sleeve, coat the parts with light oil and reassemble. The four capscrews inserted through the valve body cap to hold the air valve to the intermediate section should be torqued to 150 in./lbs. (1.728 kilograms/meter).

PILOT VALVE

This assembly is reached by removing the air distribution valve body from the pump and lifting the pilot valve body out of the intermediate housing.

When reinserting an externally serviceable pilot valve, push both plungers out of the path of the pilot valve so that they and the pilot valve are not damaged.

PILOT VALVE ACTUATOR

The bushings for the pilot valve actuators are pressed into the intermediate bracket from the outside. The plunger may be removed for inspection or replacement from the inside by removing the air distribution valve body and the pilot valve body from the pump. The plungers should be visible as you look into the intermediate from the top. Depending on their position, you may find it necessary to use a fine piece of wire to pull them out.

Under rare circumstances, it may become necessary to replace the o-ring seal. The bushing can be turned out through the inner chamber by removing the outer chamber assembly to reach the bushing.

ASSEMBLING

All procedures for reassembling the pump are the reverse of the previous instructions with further instructions as shown:

1. The diaphragm assemblies are to be installed with the natural bulge outward or toward the head of the center screw. Make sure both plates are installed with outer radii against the diaphragm.

After all components are in position in a vise and hand tight, set a torque wrench for 360 inch pounds (30 ft. lbs.) (4.147 kilograms/meter) using a (3/8") allen head socket. After each diaphragm sub assembly has been completed, thread one assembly into the shaft (held near the middle in a vise having soft jaws to protect the finish).

Make sure that 10-32 screw has been removed and that the bumper is in place in the shaft.

Install this sub assembly into the pump and secure by placing the outer chamber housing and capscrews on the end with the diaphragm. This will hold the assembly in place while the opposite side is installed. Make sure the last diaphragm assembly is torqued to 25 ft. lbs. (3.456 kilograms/meter) before placing the outer diaphragm over the capscrews. If the holes in the diaphragm flange do not line up with the holes in the chamber flange, turn the diaphragm assembly in the direction of tightening to align the holes so that the capscrews can be inserted. This final torquing of the last diaphragm assembly will lock the two diaphragm assemblies together. Place remaining outer chamber on the open end and tighten down the securing nuts gradually and evenly on both sides to 200 in./lbs. (2.3 kilogram/meter).

2. Caution should be used while reassembling check valves. The valves are designed for some preload over the retainer hinge pad. This is done to insure proper face contact with the seat. After all parts are in place, tighten the lock nuts down on the assembly to the point where visual inspection shows that seat and valve face mate without gap. This is important for dry prime. However, after priming action has started, valves will function due to differential pressure without concern or trouble.

IMPORTANT

This pump is pressurized internally with air pressure during operation. Always make certain all bolting is in good condition and that ALL of correct bolting is reinstalled during assembly.

RETAIN THIS INFORMATION FOR FUTURE REFERENCE

When ordering replacement parts, list: Part Number, Description, Model Number and Series Letter.

LINCOLN provides a Distributor Network that stocks equipment and replacement parts.