

SERVICE & OPERATING MANUAL

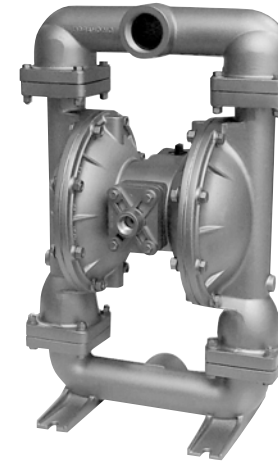

Model 85624 Series B

2" Aluminum Air-Powered Diaphragm Pump



II 2GD b T5



U.S. Patent #
5,996,627 &
6,241,487
Other U.S. Patents
Applied for

Table of Contents

Engineering Data and Temperature Limitations	1	Composite Repair Parts Drawing	10
Performance Curve	2	Available Service and Conversion Kits	10
Dimensions	3	Composite Repair Parts List	11
Metric Dimensions	4	Air Distribution Valve Assembly Drawing, Parts List and Servicing	12
Principle of Pump Operation	5	Actuator Plunger Servicing	13
Installation and Start-Up	5	Diaphragm Service Drawing	14
Air Supply	5	Diaphragm Servicing	15
Air Valve Lubrication	5	Check Valve Servicing	16
Air Line Moisture	5	Check Valve Drawing	16
Air Inlet and Priming	5	Pumping Hazardous Liquids	17
Between Uses	5	Converting Pump for Piping Exhaust Air	17
Installation Guide	6	Converted Exhaust Illustration	17
Troubleshooting	7	Grounding the Pump	18
Warranty	7	ATEX Declaration of Conformity	19
Recycling	8		
Important Safety Information	8		

Section - B5
Page - 27A

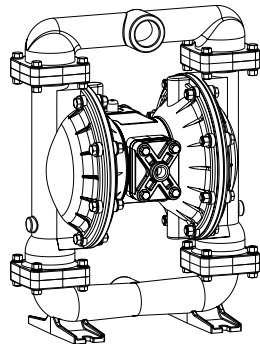

Air Inlet Side View

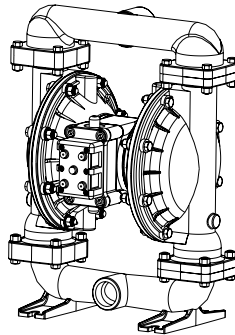

Air Exhaust Side View



II 2GD b T5



U.S. Patent #
5,996,627 &
6,241,487
Other U.S. Patents
Applied for

Model 85624 Series B

Aluminum Air-Powered Diaphragm Pump

ENGINEERING, PERFORMANCE
& CONSTRUCTION DATA

INTAKE/DISCHARGE PIPE SIZE 2" NPT(internal)	CAPACITY 0 to 150 gallons per minute (0 to 567 liters per minute)	AIR VALVE No-lube, no-stall design	SOLIDS-HANDLING Up to .25 in. (6mm)	HEADS UP TO 125 psi or 289 ft. of water (8.6 Kg/cm ² or 86 meters)	DISPLACEMENT/STROKE .42 Gallon / 1.59 liter
---	--	---	---	--	---

CAUTION! Operating temperature limitations are as follows:

Materials

Buna General purpose, oil-resistant. Shows good solvent, oil, water and hydraulic fluid resistance. Should not be used with highly polar solvents like acetone and MEK, ozone, chlorinated hydrocarbons and nitro hydrocarbons.

Polypropylene

Polyethylene

	Maximum*	Operating Temperatures	
		Minimum*	Optimum**
Buna	190°F 88°C	-10°F -23°C	50° to 140°F 10°C to 60°C
Polypropylene	150°F 65°C	-40°F -40°C	
Polyethylene	180°F 82°C	-40°F -40°C	50° to 140°F 10° to 60°C

Performance Curve

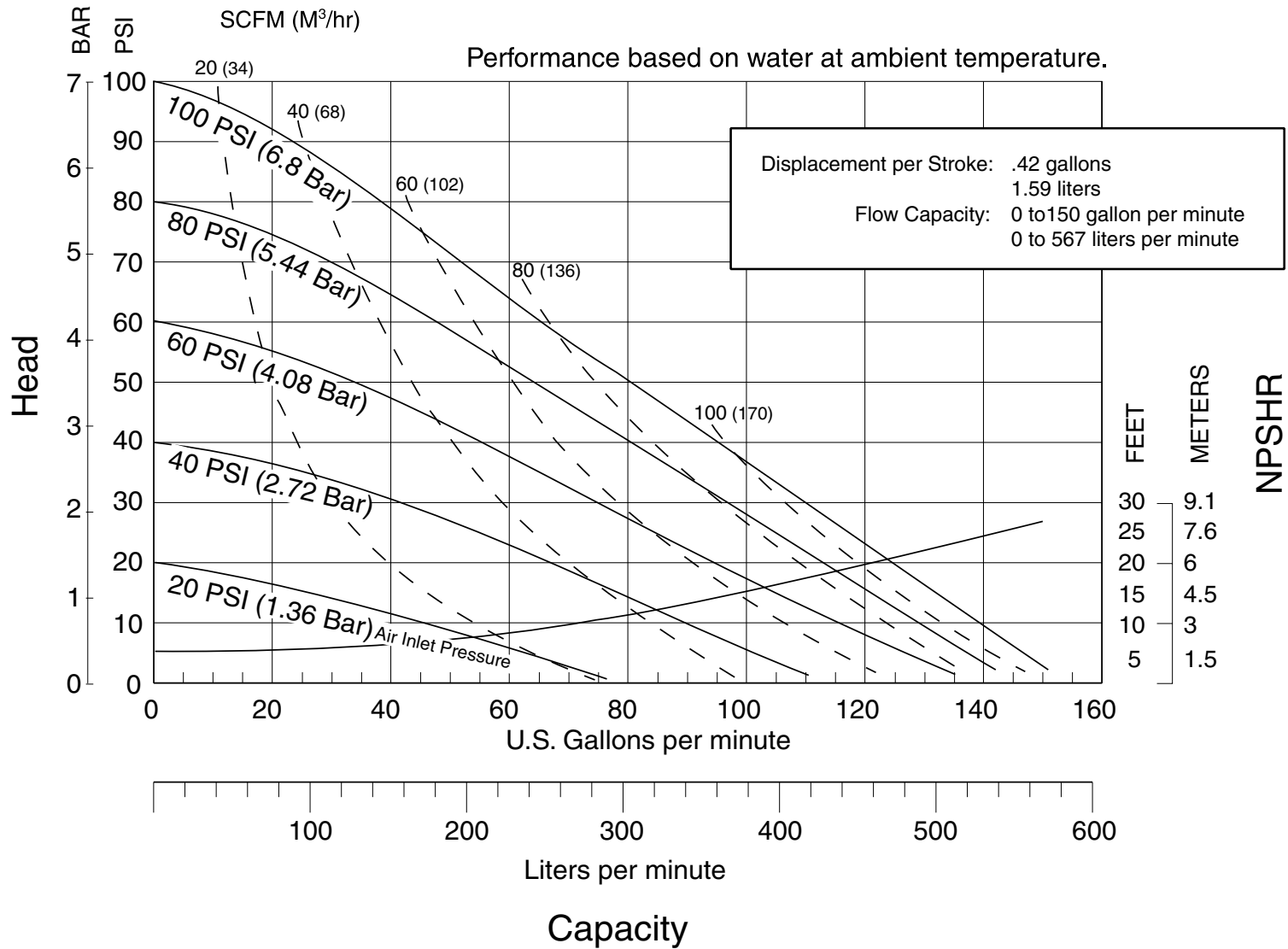

Dimensions:

Dimensions in Inches

Dimensional Tolerance: $\pm 1/8$ "

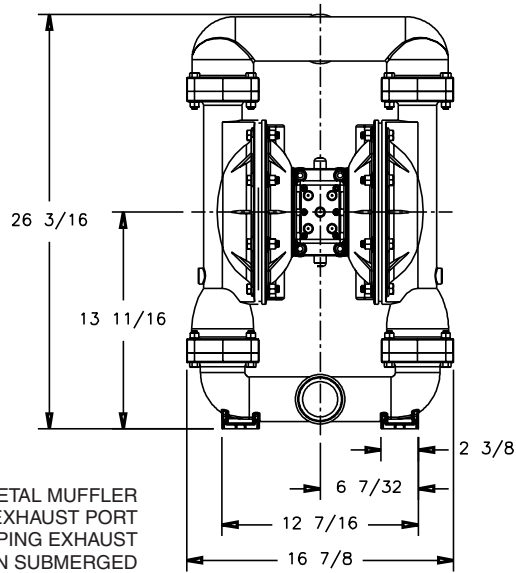

STANDARD METAL MUFFLER
1" NPT EXHAUST PORT
FOR PIPING EXHAUST
AIR IN SUBMERGED
APPLICATIONS.

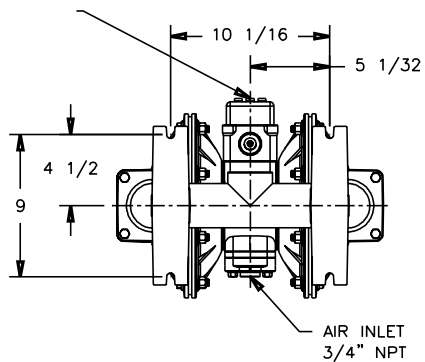
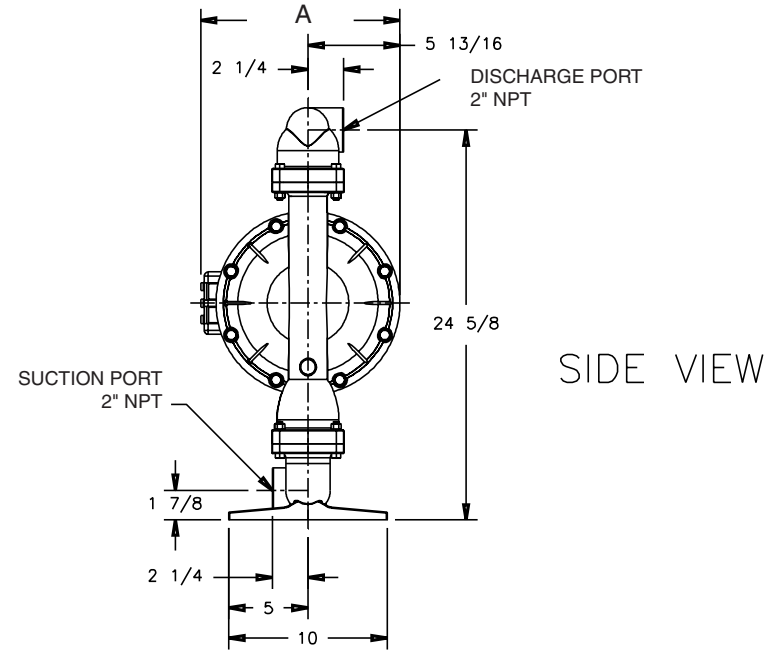

DIMENSION	A
Metal Muffler	14 11/16

Metric Dimensions:

Dimensions in Millimeters
Dimensional Tolerance: ± 3mm

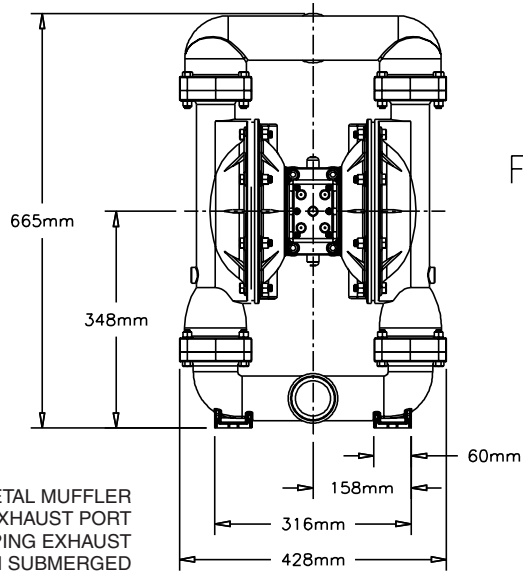

FRONT VIEW

STANDARD METAL MUFFLER
1" NPT EXHAUST PORT
FOR PIPING EXHAUST
AIR IN SUBMERGED
APPLICATIONS.

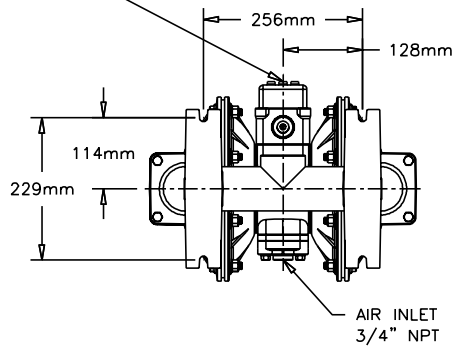

BOTTOM VIEW

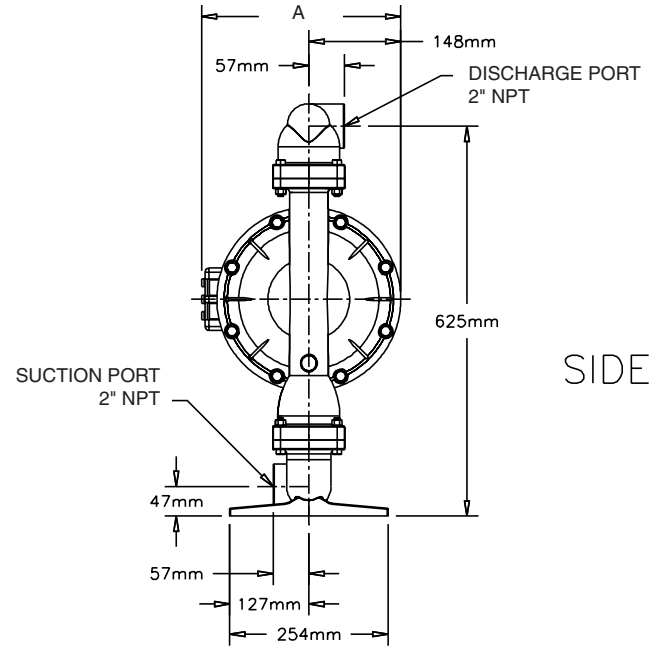

SIDE VIEW

DIMENSION	A
Metal Muffler	373

PRINCIPLE OF PUMP OPERATION

This ball type check valve pump is powered by compressed air and is a 1:1 ratio design. The inner side of one diaphragm chamber is alternately pressurized while simultaneously exhausting the other inner chamber. This causes the diaphragms, which are connected by a common rod secured by plates to the centers of the diaphragms, to move in a reciprocating action. (As one diaphragm performs the discharge stroke the other diaphragm is pulled to perform the suction stroke in the opposite chamber.) Air pressure is applied over the entire inner surface of the diaphragm while liquid is discharged from the opposite side of the diaphragm. The diaphragm operates in a balanced condition during the discharge stroke which allows the pump to be operated at discharge heads over 200 feet (61 meters) of water.

For maximum diaphragm life, keep the pump as close to the liquid being pumped as possible. Positive suction head in excess of 10 feet of liquid (3.048 meters) may require a back pressure regulating device to maximize diaphragm life.

Alternate pressurizing and exhausting of the diaphragm chamber is performed by an externally mounted, pilot operated, four way spool type air distribution valve. When the spool shifts to one end of the valve body, inlet pressure is applied to one diaphragm chamber and the other diaphragm chamber exhausts. When the spool

shifts to the opposite end of the valve body, the pressure to the chambers is reversed. The air distribution valve spool is moved by an internal pilot valve which alternately pressurizes one end of the air distribution valve spool while exhausting the other end. The pilot valve is shifted at each end of the diaphragm stroke when an actuator plunger is contacted by the diaphragm plate. This actuator plunger then pushes the end of the pilot valve spool into position to activate the air distribution valve.

The chambers are connected with manifolds with a suction and discharge check valve for each chamber, maintaining flow in one direction through the pump.

INSTALLATION AND START-UP

Locate the pump as close to the product being pumped as possible. Keep the suction line length and number of fittings to a minimum. Do not reduce the suction line diameter.

For installations of rigid piping, short sections of flexible hose should be installed between the pump and the piping. The flexible hose reduces vibration and strain to the pumping system. A surge suppressor is recommended to further reduce pulsation in flow.

In systems where a closed discharge may occur, thermal expansion of the fluid can cause a hazardous, high-pressure condition. To prevent damage to equipment and or personnel, place a pressure relief valve in the system. The pressure relief valve should be set to relieve pressure in the system at 150 psi

and the pressure relief valve should be located near the outlet of the pump with provision for return to tank. (See recommended installation drawing on page 6).

AIR SUPPLY

Air supply pressure cannot exceed 125 psi (8.6 bar). Connect the pump air inlet to an air supply of sufficient capacity and pressure required for desired performance. When the air supply line is solid piping, use a short length of flexible hose not less than ½" (13mm) in diameter between the pump and the piping to reduce strain to the piping. The weight of the air supply line, regulators and filters must be supported by some means other than the air inlet cap. Failure to provide support for the piping may result in damage to the pump. A pressure regulating valve should be installed to insure air supply pressure does not exceed recommended limits.

AIR VALVE LUBRICATION

The air distribution valve and the pilot valve are designed to operate WITHOUT lubrication. This is the preferred mode of operation. There may be instances of personal preference or poor quality air supplies when lubrication of the compressed air supply is required. The pump air system will operate with properly lubricated compressed air supply. Proper lubrication requires the use of an air line lubricator set to deliver one drop of SAE 10 non-detergent oil for every 20 SCFM (9.4 liters/sec.) of air the pump consumes at the point of operation.

Consult the pump's published Performance Curve to determine this.

AIR LINE MOISTURE

Water in the compressed air supply can create problems such as icing or freezing of the exhaust air, causing the pump to cycle erratically or stop operating. Water in the air supply can be reduced by using a point-of-use air dryer to supplement the user's air drying equipment. This device removes water from the compressed air supply and alleviates the icing or freezing problems.

AIR INLET AND PRIMING

To start the pump, open the air valve approximately ½ to ¾ turn. After the pump primes, the air valve can be opened to increase air flow as desired. If opening the valve increases cycling rate, but does not increase the rate of flow, cavitation has occurred. The valve should be closed slightly to obtain the most efficient air flow to pump flow ratio.

BETWEEN USES

When the pump is used for materials that tend to settle out or solidify when not in motion, the pump should be flushed after each use to prevent damage. (Product remaining in the pump between uses could dry out or settle out. This could cause problems with the diaphragms and check valves at restart.) In freezing temperatures the pump must be completely drained between uses in all cases.

INSTALLATION GUIDE

Top Discharge Ball Valve Unit

- ① Surge Suppressor
- ② Filter/Regulator

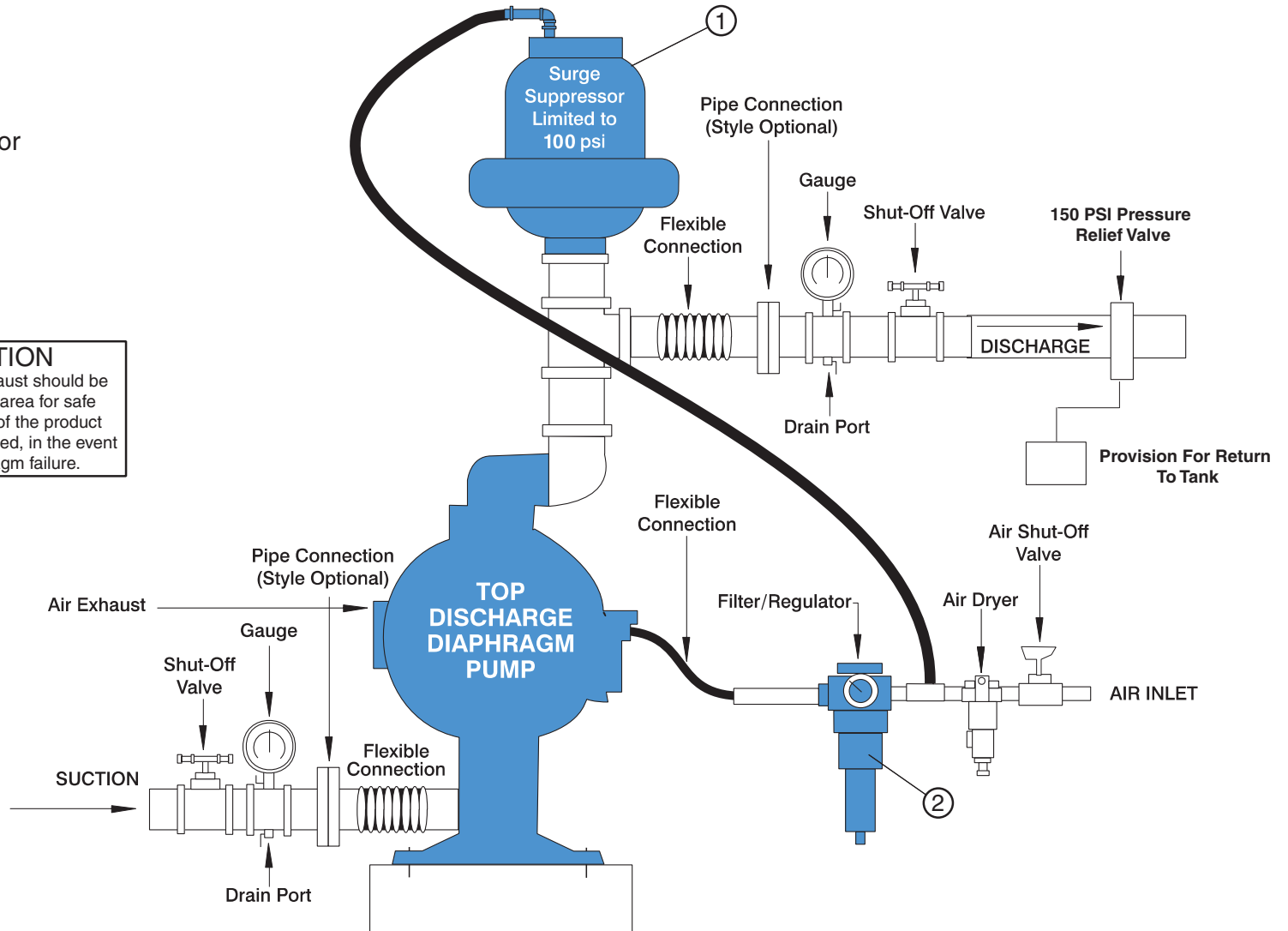
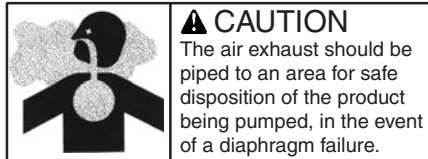

TROUBLESHOOTING

Possible Symptoms:

- Pump will not cycle.
- Pump cycles, but produces no flow.
- Pump cycles, but flow rate is unsatisfactory.
- Pump cycle seems unbalanced.
- Pump cycle seems to produce excessive vibration.

What to Check: Excessive suction lift

Corrective Action: For lifts exceeding 20 feet (6 meters), filling the pumping chambers with liquid will prime the pump in most cases.

What to Check: Excessive flooded suction in system.

Corrective Action: For flooded conditions exceeding 10 feet (3 meters) of liquid, install a back pressure device.

What to Check: System head exceeds air supply pressure.

Corrective Action: Increase the inlet air pressure to the pump. Most diaphragm pumps are designed for 1:1 pressure ratio at zero flow.

What to Check: Air supply pressure or volume exceeds system head.

Corrective Action: Decrease inlet air pressure and volume to the pump as calculated on the published PERFORMANCE CURVE. Pump is cavitating the fluid by fast cycling.

What to Check: Undersized suction line.

Corrective Action: Meet or exceed pump connection recommendations shown on the DIMENSIONAL DRAWING.

What to Check: Restricted or undersized air line.

Corrective Action: Install a larger air line and connection. Refer to air inlet recommendations shown in your pump's SERVICE MANUAL.

What to Check: Check ESADS, the Externally Serviceable Air Distribution System of the pump.

Corrective Action: Disassemble and inspect the main air distribution valve, pilot valve and pilot valve actuators. Refer to the parts drawing and air valve section of the SERVICE MANUAL. Check for clogged discharge or closed valve before reassembly.

What to Check: Rigid pipe connections to pump.

Corrective Action: Install flexible connectors and a surge suppressor.

What to Check: Blocked air exhaust muffler.

Corrective Action: Remove muffler screen, clean or de-ice and reinstall. Refer to the Air Exhaust section of your pump SERVICE MANUAL.

What to Check: Pumped fluid in air exhaust muffler.

Corrective Action: Disassemble pump chambers. Inspect for diaphragm rupture or loose diaphragm plate assembly. Refer to the Diaphragm Replacement section of your pump SERVICE MANUAL.

What to Check: Suction side air leakage or air in product.

Corrective Action: Visually inspect all suction side gaskets and pipe connections.

What to Check: Obstructed check valve.

Corrective Action: Disassemble the wet end of the pump and manually dislodge obstruction in the check valve pocket. Refer to the Check Valve section of the pump SERVICE MANUAL for disassembly instructions.

What to Check: Worn or misaligned check valve or check valve seat.

Corrective Action: Inspect check valves and seats for wear and proper seating. Replace if necessary. Refer to Check Valve section of the pump SERVICE MANUAL for disassembly instructions.

What to Check: Blocked suction line.

Corrective Action: Remove or flush obstruction. Check and clear all suction screens and strainers.

What to Check: Blocked discharge line.

Corrective Action: Check for obstruction or closed discharge line valves.

What to Check: Blocked pumping chamber.

Corrective Action: Disassemble and inspect the wetted chambers of the pump. Remove or flush any obstructions. Refer to the pump SERVICE MANUAL for disassembly instructions.

What to Check: Entrained air or vapor lock in one or both pumping chambers.

Corrective Action: Purge chambers through tapped chamber vent plugs. PURGING THE CHAMBERS OF AIR CAN BE DANGEROUS! Contact the Technical Services Department before performing this procedure. Any model with top-ported discharge will reduce or eliminate problems with entrained air.

If your pump continues to perform below your expectations, contact your local Distributor or factory Technical Services Group for a service evaluation.

WARRANTY

This pump is warranted for a period of five years for defective material and workmanship.

RECYCLING

Many components of LINCOLN AODD pumps are made of recyclable materials (see chart on page 10 for material specifications). We encourage pump users to recycle worn out parts and pumps whenever possible, after any hazardous pumped fluids are thoroughly flushed.

IMPORTANT SAFETY INFORMATION



IMPORTANT

Read these safety warnings and instructions in this manual completely, before installation and start-up of the pump. It is the responsibility of the purchaser to retain this manual for reference. Failure to comply with the recommendations stated in this manual will damage the pump, and void factory warranty.



WARNING

Take action to prevent static sparking. Fire or explosion can result, especially when handling flammable liquids. The pump, piping, valves, containers or other miscellaneous equipment must be grounded. (See page 18)



WARNING

This pump is pressurized internally with air pressure during operation. Always make certain that all bolting is in good condition and that all of the correct bolting is reinstalled during assembly.



CAUTION

Before pump operation, inspect all gasketed fasteners for looseness caused by gasket creep. Re-torque loose fasteners to prevent leakage. Follow recommended torques stated in this manual.



WARNING

When used for toxic or aggressive fluids, the pump should always be flushed clean prior to disassembly.



CAUTION

In systems where a closed discharge may occur, thermal expansion of the fluid can cause hazardous, high-pressure conditions. Follow instructions in the Installation and Start-Up section of this manual.



WARNING

Before maintenance or repair, shut off the compressed air line, bleed the pressure, and disconnect the air line from the pump. The discharge line may be pressurized and must be bled of its pressure.



WARNING

Before doing any maintenance on the pump, be certain all pressure is completely vented from the pump, suction, discharge, piping, and all other openings and connections. Be certain the air supply is locked out or made non-operational, so that it cannot be started while work is being done on the pump. Be certain that approved eye protection and protective clothing are worn all times in the vicinity of the pump. Failure to follow these recommendations may result in serious injury or death.



WARNING

In the event of diaphragm rupture, pumped material may enter the air end of the pump, and be discharged into the atmosphere. If pumping a product which is hazardous or toxic, the air exhaust must be piped to an appropriate area for safe disposition.



WARNING

Airborne particles and loud noise hazards. Wear ear and eye protection.



II 2GD b T5

Pump complies with EN809 Pumping Directive and Directive 98/37/EC Safety of Machinery, and ATEX 100a Directive 94/9/EC Equipment for use in Potentially Explosive Environments.



Composite Repair Parts Drawing

AVAILABLE SERVICE AND CONVERSION KITS

271770

WET END KIT

Buna Diaphragms, Balls, and Seats.

273040

AIR END KIT

Seals, O-rings, Gaskets, Retaining Rings, Air Valve Assembly, and Pilot Valve Assembly

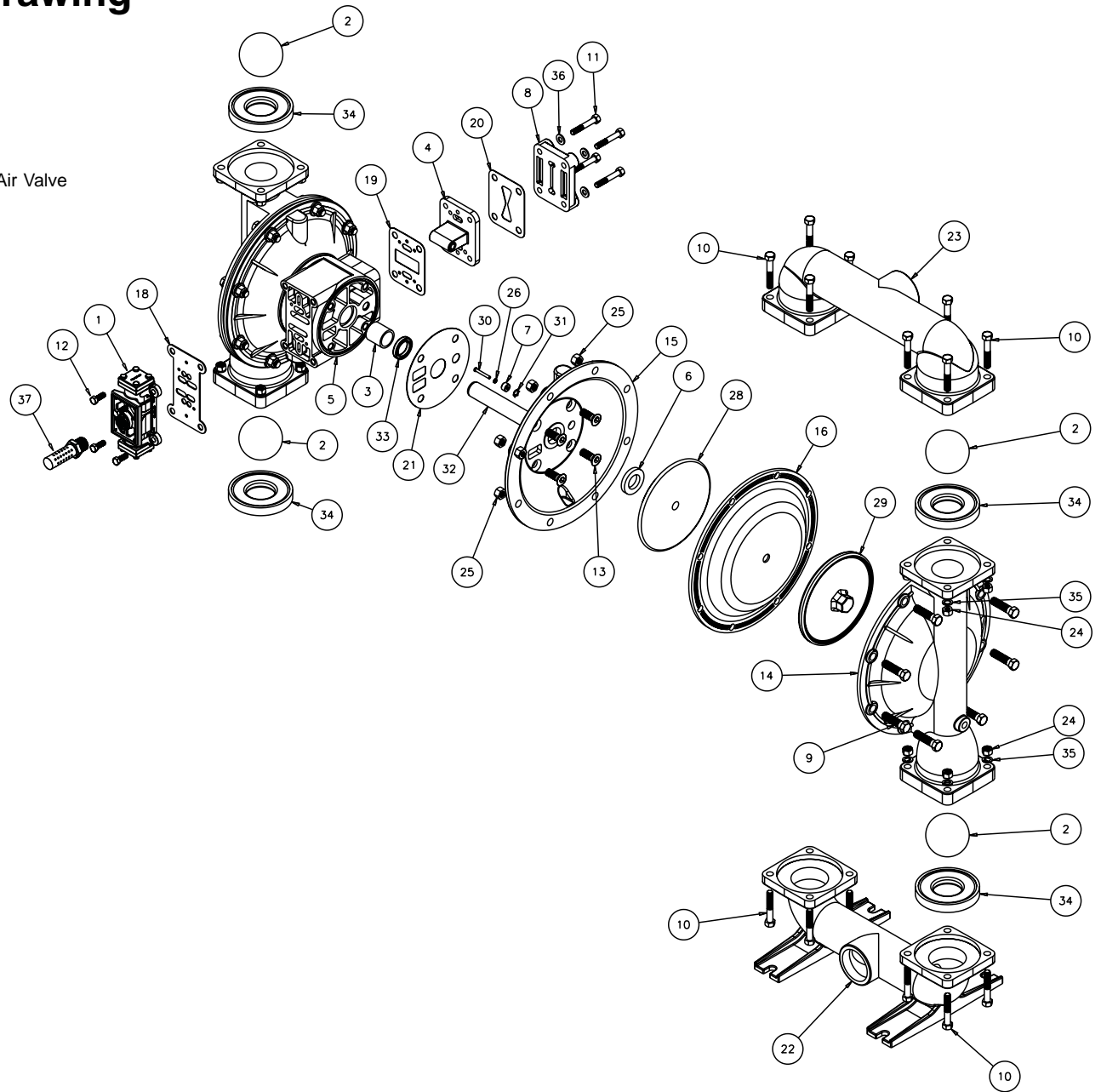

Composite Repair Parts List

ITEM	DESCRIPTION	QTY	MODEL 85624 Series B
1	Air Valve Assembly	1	273013
2	Ball, Check	4	240903
3	Bearing, Sleeve	2	240922
4	Pilot Valve Assembly	1	273014
5	Bracket, Intermediate	1	271785
6	Bumper	2	271786
7	Bushing, Plunger	2	271787
8	Cap, Air Inlet	1	271788
9	Capscrew, Hex Head 7/16UNC x 2.00 long	16	271754
10	Capscrew, Hex Head 3/8-16UNC x 2.25 long	16	271789
11	Capscrew, Hex Head 5/16-18UNC x 2.00 long	4	271790
12	Capscrew, Socket Head 3/8-16UNC x 2.50 long	4	273015
13	Capscrew, Flat Socket Head 7/16-14UNC x 1.25	8	271792
14	Chamber, Outer	2	271793
15	Chamber, Inner	2	271794
16	Diaphragm	2	240900
18	Gasket, Air Valve	1	273016
19	Gasket, Pilot Valve	1	273017
20	Gasket, Air Inlet	1	273018
21	Gasket, Inner Chamber	2	273019
22	Manifold, Suction	1	271799
23	Manifold, Discharge	1	271800
24	Nut, Hex 3/8-16UNC	16	271801
25	Nut, Hex 7/16-14UNC	16	240911
26	O-Ring	2	240655
28	Plate, Inner Diaphragm	2	271804
29	Plate, Outer Diaphragm	2	240805
30	Plunger, Actuator	2	271806
31	Ring, Retaining	2	240717
32	Rod, Diaphragm	1	271807
33	Seal, U-Cup	2	243134
34	Seat, Check Valve	4	271767
35	Washer, Lock	16	271808
36	Washer, Flat 5/16	4	271809
37	Muffler	1	273020

Air Valve Assembly Drawing, Parts List and Servicing

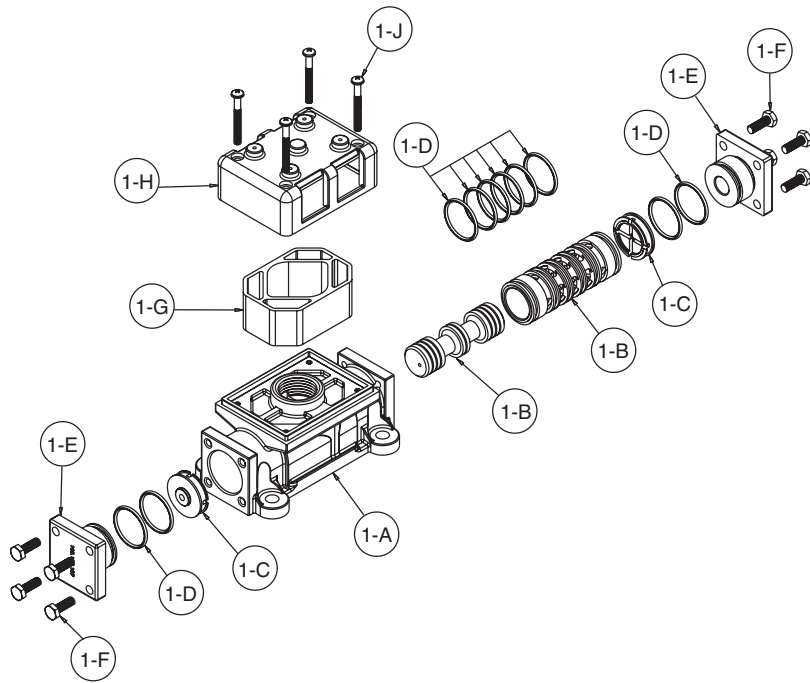

#273013 From Pages 10 & 11

Item	Part Number	Description	Qty
1-A	273041	Air Valve Body	1
1-B	271774	Sleeve and Spool Set	1
1-C	273042	Bumper	2
1-D	240932	O-Ring	10
1-E	273043	End Cap	2
1-F	273044	Hex Head Capscrew 1/4-20 x .75 Long	8

AIR DISTRIBUTION VALVE SERVICING

To service the air valve first shut off the compressed air, bleed pressure from the pump, and disconnect the air supply line from the pump.

Step #1: See COMPOSITE REPAIR PARTS DRAWING.

Using a 9/16" wrench or socket, remove the four hex capscrews (items 12). Remove the air valve assembly from the pump.

Remove and inspect gasket (item 18) for cracks or damage. Replace gasket if needed.

Step #2: Disassembly of the air valve.

Using a 7/16" wrench or socket, remove the eight hex capscrews (items 1-F) that

fasten the end caps to the valve body. Next remove the two end caps (items 1-E). Inspect the two o-rings (items 1-D) on each end cap for damage or wear. Replace the bumpers as needed.

Remove the bumpers (items 1-C). Inspect the bumpers for damage or wear. Replace the bumpers as needed.

Remove the spool (part of item 1-B) from the sleeve. Be careful not to scratch or damage the outer diameter of the spool. Wipe spool with a soft cloth and inspect for scratches or wear.

Inspect the inner diameter of the sleeve (part of item 1-B) for dirt, scratches, or other contaminants. Remove the sleeve if needed and replace with a new sleeve and spool set (item 1-B).

Step #3: Reassembly of the air valve.

Install one bumper (item 1-C) and one end cap (item 1-E), with two o-rings (items 1-D), and fasten with four hex capscrews (items 1-F) to the valve body (item 1-A).

Remove the new sleeve and spool set (item 1-B) from the plastic bag. Carefully remove the spool from the sleeve. Install the six o-rings (item 1-D) into the six grooves on the sleeve. Apply a light coating of grease to the o-rings before installing the sleeve into the valve body (item 1-A), align the slots in the sleeve with the slots in the valve body. Insert the spool into the sleeve. Be careful not to scratch or damage the spool during installation. Carefully insert the sleeve into the bumper and end cap (with o-rings) and fasten with the

remaining hex capscrews.

Fasten the air valve assembly (item 1) and gasket to the pump. Connect the compressed air line to the pump. The pump is now ready for operation.



! IMPORTANT

Read these instructions completely, before installation and start-up. It is the responsibility of the purchaser to retain this manual for reference. Failure to comply with the recommendations stated in this manual will damage the pump, and void factory warranty.

ACTUATOR PLUNGER SERVICING

To service the actuator plunger first shut off the compressed air supply, bleed the pressure from the pump, and disconnect the air supply line from the pump.

Step #1: See PUMP ASSEMBLY DRAWING.

Using a 1/2" wrench or socket, remove the four capscrews (items 11). Remove the air inlet cap (item 8) and air inlet gasket (item 20). The pilot valve assembly (item 4) can now be removed.

Step #2: Inspect the actuator plungers.

See ILLUSTRATION AT RIGHT.

The actuator plungers (items 30) can be reached through the pilot valve cavity in the intermediate assembly (item 5).

Remove the plungers (item 30) from the bushings (item 7) in each end of the cavity. Inspect the installed o-ring (items 26) for cuts and/or wear. Replace the o-rings if necessary. Apply a light coating of grease to each o-ring and re-install the plungers in to the bushings. Push the plungers in as far as they will go.

To remove the bushings (item 7), first remove the retaining rings (item 31) by using a flat screwdriver.

NOTE: It is recommended that new retaining rings be installed.

Step #3: Re-install the pilot valve assembly into the intermediate assembly.

Be careful to align the ends of the stem between the plungers when inserting the stem of the pilot valve into the cavity of the intermediate.

Re-install the gasket (item 20), air inlet cap (item 8) and capscrews (item 11).

Connect the air supply to the pump. The pump is now ready for operation.

ACTUATOR PLUNGER SERVICING

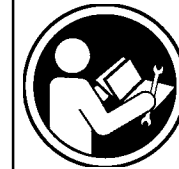
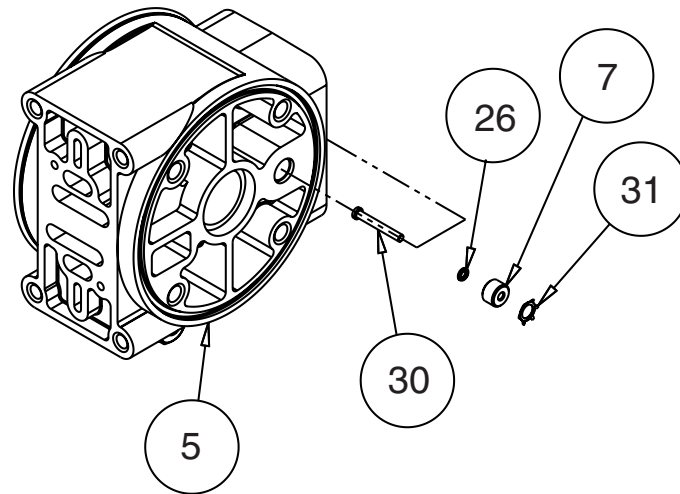

IMPORTANT

Read these instructions completely, before installation and start-up. It is the responsibility of the purchaser to retain this manual for reference. Failure to comply with the recommendations stated in this manual will damage the pump, and void factory warranty.

Diaphragm Service Drawing

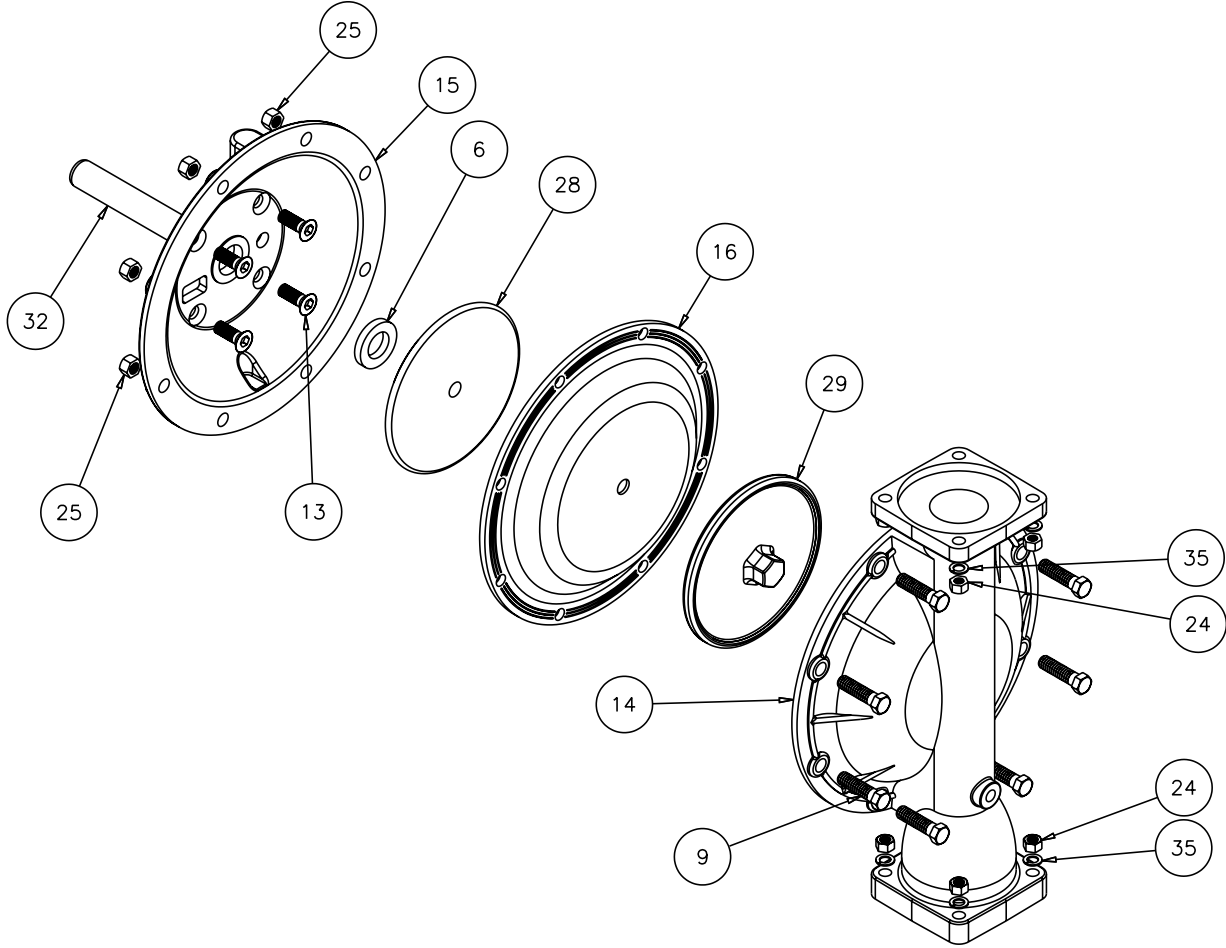

DIAPHRAGM SERVICING

To service the diaphragms first shut off the suction, then shut off the discharge lines to the pump. Shut off the compressed air supply, bleed the pressure from the pump, and disconnect the air supply line from the pump. Drain any remaining liquid from the pump.

Step #1: See the pump assembly drawing, and the diaphragm servicing illustration.

Using a $\frac{9}{16}$ " wrench or socket, remove the 16 capscrews (item 10), hex nuts, and lockwashers that fasten the manifolds (items 22 & 23) to the outer chambers (item 14).

Step #2: Removing the outer chambers.

Using a $\frac{11}{16}$ " and a $\frac{5}{8}$ " wrench or socket, remove the 16 capscrews (items 9), and hex nuts that fasten the outer chambers, diaphragms, and inner chambers (items 15) together.

Step #3: Removing the diaphragm assemblies.

Use a $1\frac{1}{16}$ " (27mm) wrench or six pointed socket to remove the diaphragm assemblies (outer plate, diaphragm, and inner plate) from the diaphragm rod (item 32) by turning counterclockwise.

Insert a 1/4-20 capscrew or set screw into the smaller tapped hole in the inner diaphragm plate (item 28). Insert the protruding stud and the 1/4-20 fastener loosely into a vise. Use a $1\frac{1}{16}$ " wrench or socket to remove the outer diaphragm plate (item 29) by turning counterclockwise. Inspect the diaphragm

(item 16) for cuts, punctures, abrasive wear or chemical attack. Replace the diaphragms if necessary.

Step #4: Installing the diaphragms.

Push the threaded stud of the outer diaphragm plate through the center hole of the diaphragm. Thread the inner plate clockwise onto the stud. Insert the loose assembly with the above 1/4-20 fastener back into the vise. Use a torque wrench to tighten the diaphragm assembly together to 480 in. lbs. (54.23 Newton meters). Allow a minimum of 15 minutes to elapse after torquing, then re-torque the assembly to compensate for stress relaxation in the clamped assembly.

Step #5: Installing the diaphragm assemblies to the pump.

Make sure the bumper (item 6) is installed over the diaphragm rod.

Thread the stud of the one diaphragm assembly clockwise into the tapped hole at the end of the diaphragm rod (item 32) until the inner diaphragm plate is flush to the end of the rod. Insert rod into pump.

Align the bolt holes in the diaphragm with the bolt pattern in the inner chamber (item 15).

Fasten the outer chamber (item 14) to the pump, using the capscrews (item 9), and hex nuts.

On the opposite side of the pump, pull the diaphragm rod out as far as possible. Make sure the bumper (item 6) is installed over the diaphragm rod.

Thread the stud of the remaining diaphragm assembly clockwise into the tapped hole at the end of the diaphragm rod (item 32) as far as possible and still

allow for alignment of the bolt holes in the diaphragm with the bolt pattern in the inner chamber (item 15).

Fasten the remaining outer chamber (item 14) to the pump, using the capscrews (items 9), hex nuts, and lockwashers.

Step #6: Re-install the manifolds to the pump, using the capscrews (item 10), hex nuts and flat washers.

The pump is now ready to be re-installed, connected and returned to operation.

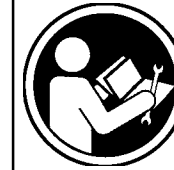

! IMPORTANT

Read these instructions completely, before installation and start-up. It is the responsibility of the purchaser to retain this manual for reference. Failure to comply with the recommendations stated in this manual will damage the pump, and void factory warranty.

CHECK VALVE SERVICING

Before servicing the check valve components, first shut off the suction line and then the discharge line to the pump. Next, shut off the compressed air supply, bleed air pressure from the pump, and disconnect the air supply line from the pump. Drain any remaining fluid from the pump. The pump can now be removed for service.

To access the check valve components, remove the manifold (item 23 or item 22 not shown). Use a $\frac{9}{16}$ " wrench or socket to remove the fasteners. Once the manifold is removed, the check valve components can be seen.

Inspect the check balls (items 2) for wear, abrasion, or cuts on the spherical surface. The check valve seats (item 34) should be inspected for cuts, abrasive wear, or embedded material on the surfaces of both the external and internal chambers. The spherical surface of the check balls must seat flush to the surface of the check valve seats for the pump to operate to peak efficiency. Replace any worn or damaged parts as necessary.

Re-assemble the check valve components. The seat should fit into the counter bore of the outer chamber.

The pump can now be reassembled, reconnected and returned to operation.

Check Valve Drawing

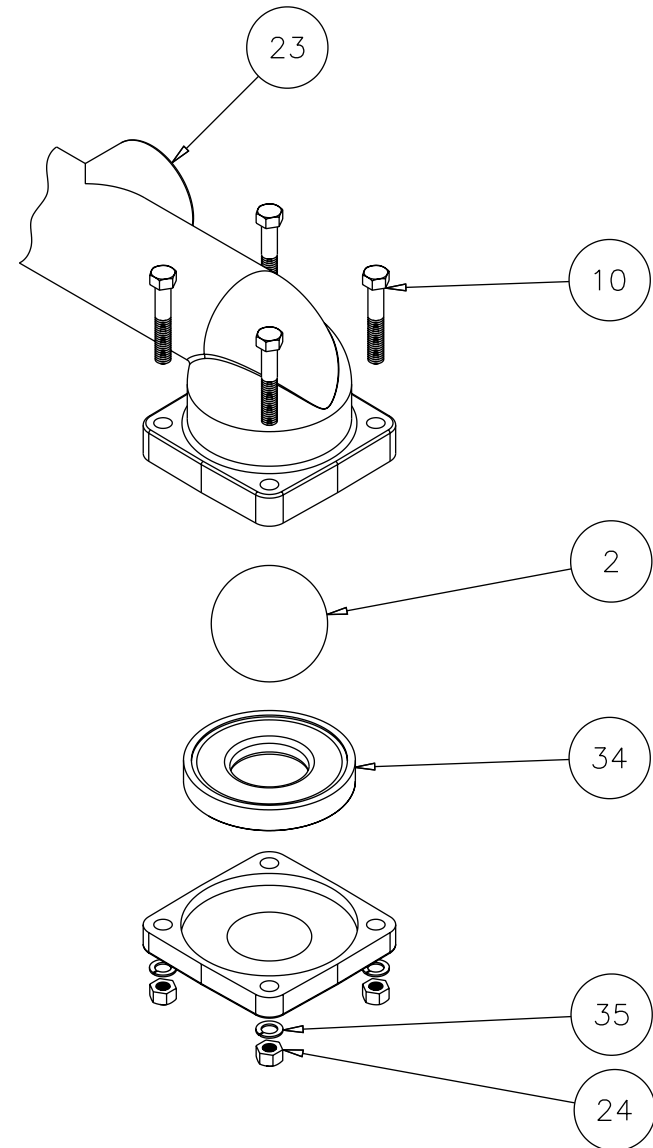

PUMPING HAZARDOUS LIQUIDS

When a diaphragm fails, the pumped liquid or fumes enter the air end of the pump. Fumes are exhausted into the surrounding environment. When pumping hazardous or toxic materials, the exhaust air must be piped to an appropriate area for safe disposal. See illustration #1 at right.

This pump can be submerged if the pump materials of construction are compatible with the liquid being pumped. The air exhaust must be piped above the liquid level. See illustration #2 at right. Piping used for the air exhaust must not be smaller than 1" (2.54 cm) diameter. Reducing the pipe size will restrict air flow and reduce pump performance. When the pumped product source is at a higher level than the pump (flooded suction condition), pipe the exhaust higher than the product source to prevent siphoning spills. See illustration #3 at right.

CONVERTING THE PUMP FOR PIPING THE EXHAUST AIR

The following steps are necessary to convert the pump to pipe the exhaust air away from the pump.

The air valve assembly (item 1) has 1" NPT threads for piped exhaust.

IMPORTANT INSTALLATION

NOTE: The manufacturer recommends installing a conductive flexible hose or connection between the pump and any rigid plumbing. This reduces stresses on the molded plastic threads of the air

exhaust port. Failure to do so may result in damage to the air distribution valve body.

Any piping or hose connected to the pump's air exhaust port must be conductive and physically supported. Failure to support these connections could also result in damage to the air distribution valve body.

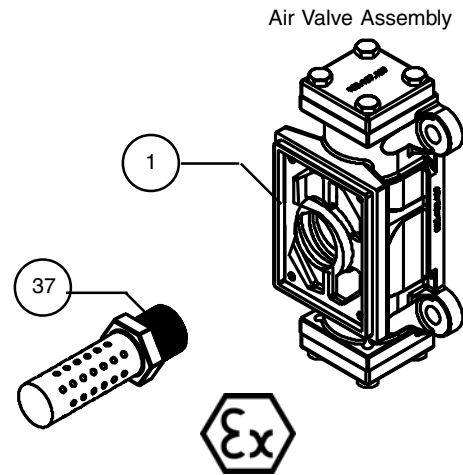

On ATEX compliant units the pump comes equipped with a standard metal muffler

CONVERTED EXHAUST ILLUSTRATION

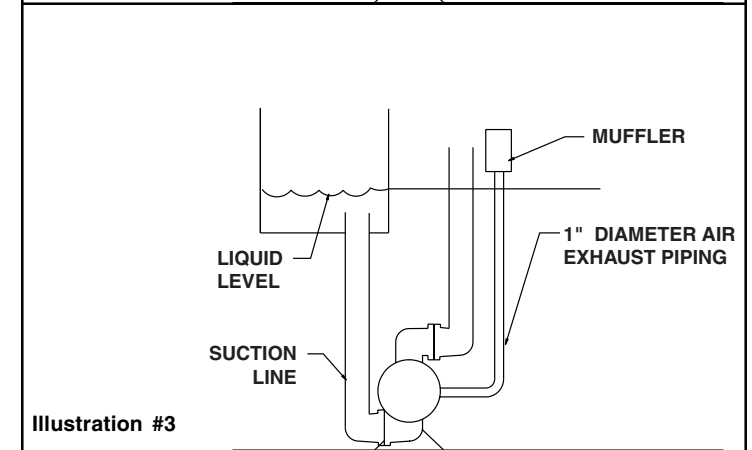
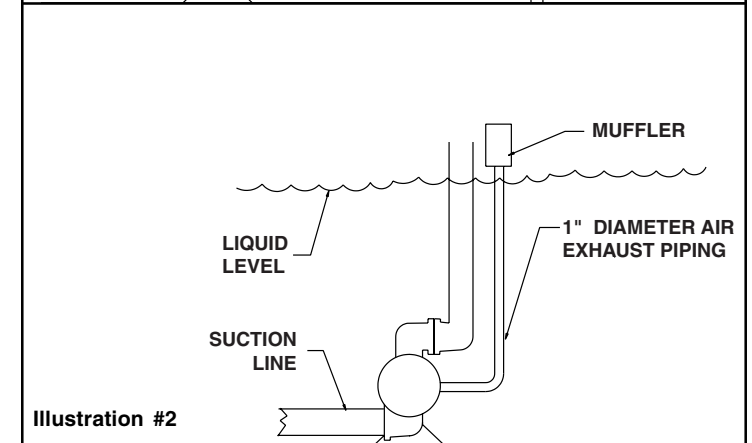
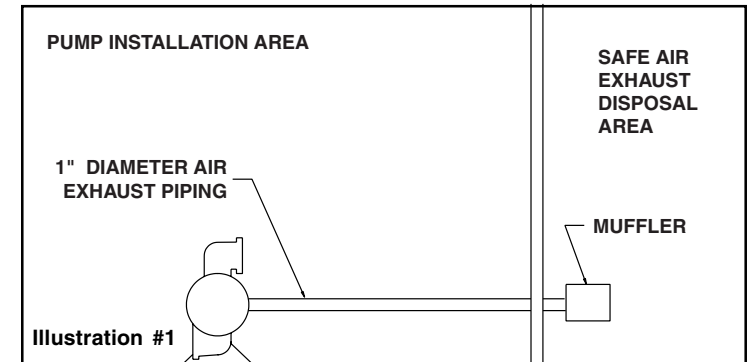

Grounding The Pump

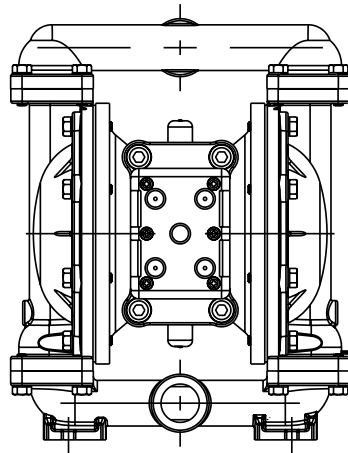
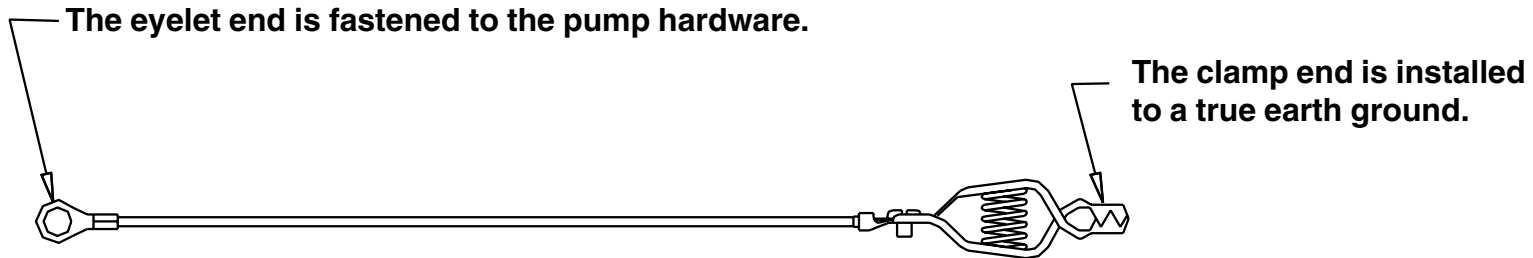

This 8 foot long (244 centimeters) Ground Strap, part number 920-025-000, can be ordered as a service item.

To reduce the risk of static electrical sparking, this pump must be grounded. Check the local electrical code for detailed grounding instruction and the type of equipment required.

	! WARNING
	<i>Take action to prevent static sparking. Fire or explosion can result, especially when handling flammable liquids. The pump, piping, valves, containers or other miscellaneous equipment must be grounded.</i>

**WARREN
RUPP®**

IDEX
IDEX CORPORATION

Declaration of Conformity ATEX 100a

In accordance with Directive 94/9/EC, Annex VIII Equipment
intended for use in potentially explosive environments.

Manufacturer:
Warren Rupp, Inc.
800 North Main Street
P.O. Box 1568
Mansfield, OH 44902 USA



Models:
Air-Operated Double Diaphragm Metallic Pumps
Series: B

LINCOLN
®

DATE/APPROVAL/TITLE:
8 May 2003

Jason Awad, V P Engineering