

RATIO	LUBRICANT OUTPUT(CU. IN.)		RESERVOIR CAPACITY	AIR INLET	LUBRICANT OUTLET	LUBRICANT OPERATING PRESSURE (PSI)			
	PER CYCLE	PER MIN. (@100PSI)				TYPE OF SYSTEM	MINIMUM	MAXIMUM	RECOM-MENDED
40:1	*.11	12	15 Pints	1/8" NPTF(F)	3/4" NPTF(F)	SL-41 SL-42 SL-43	750	1,000	850

**TYPICAL INSTALLATION**

The 283167 Pump is used as the pumping unit for a centralized lubrication system having a single line circuit of SL-41, SL-42, SL-43 or SL-44 Injectors.

It is an air operated reciprocating pump that discharges an established amount of lubricant \*(.11 cu. in.) into the circuit for each pump cycle.

\* Based on lubricants that are free of entrapped air. Lubricants that are aerated will reduce output of pump.

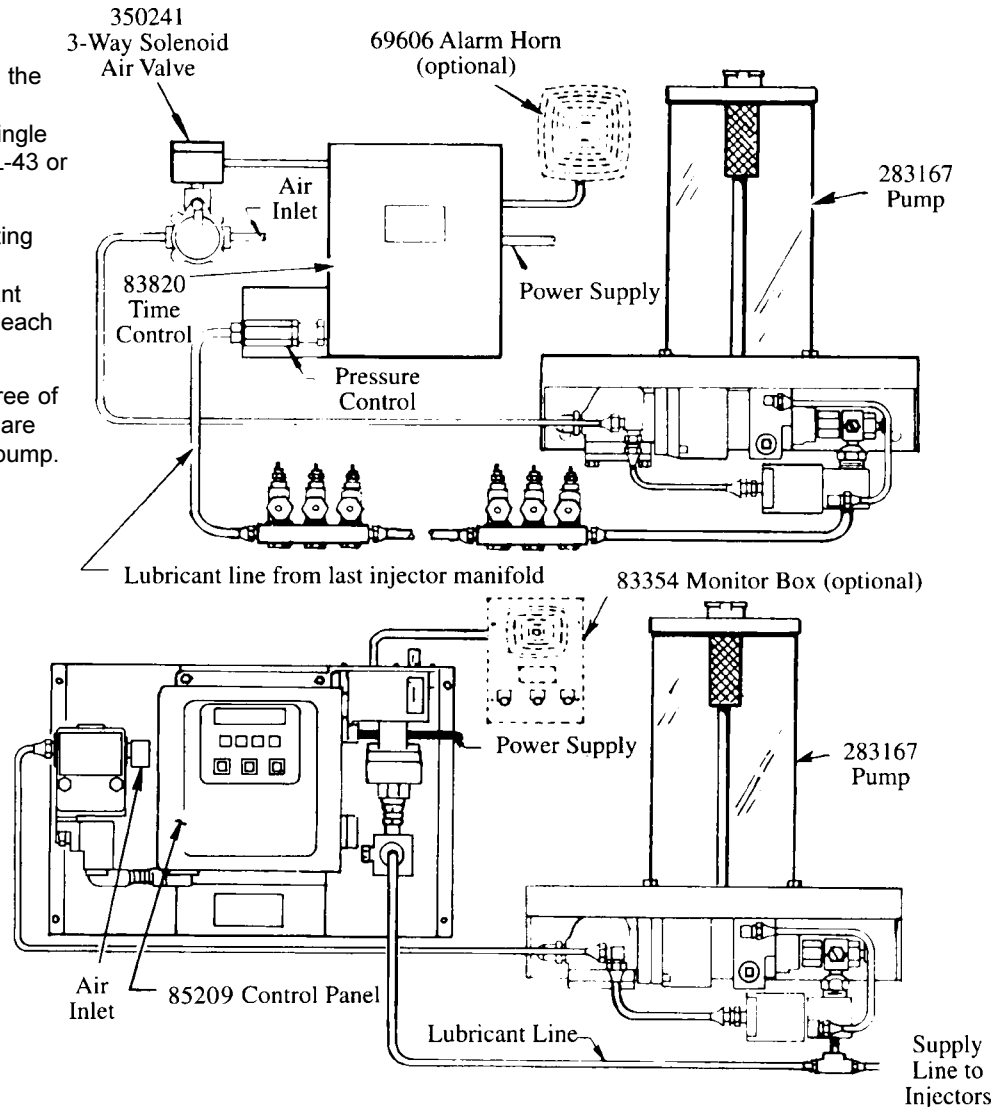

**WARNING**  
**DO NOT OPERATE THIS UNIT WITH COMBUSTIBLE GAS**

**TO FILL RESERVOIR**

The lubricant reservoir is filled through the filler cap at the top of the reservoir. A strainer is located in the filler cap. Strainer should be removed from the filler cap and cleaned periodically.

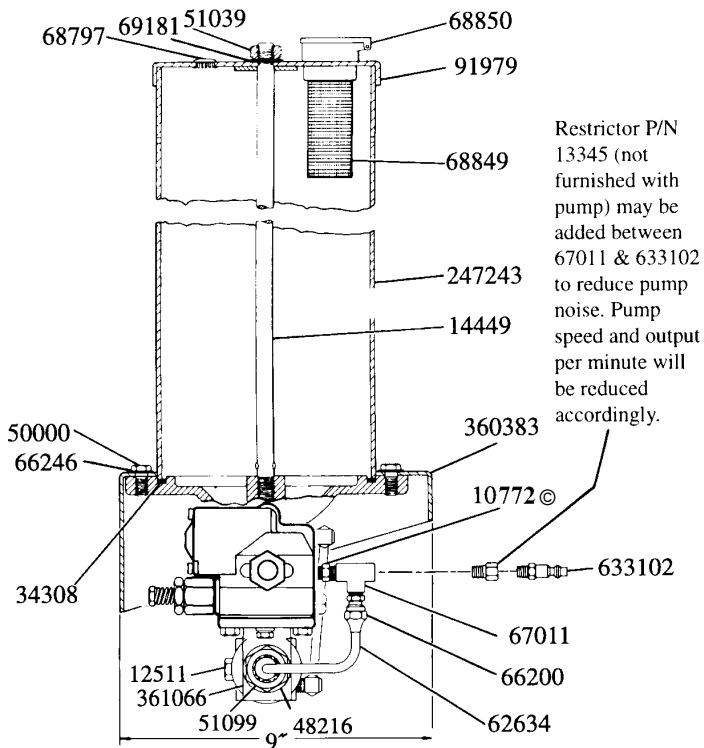

Restrictor P/N 13345 (not furnished with pump) may be added between 67011 & 633102 to reduce pump noise. Pump speed and output per minute will be reduced accordingly.

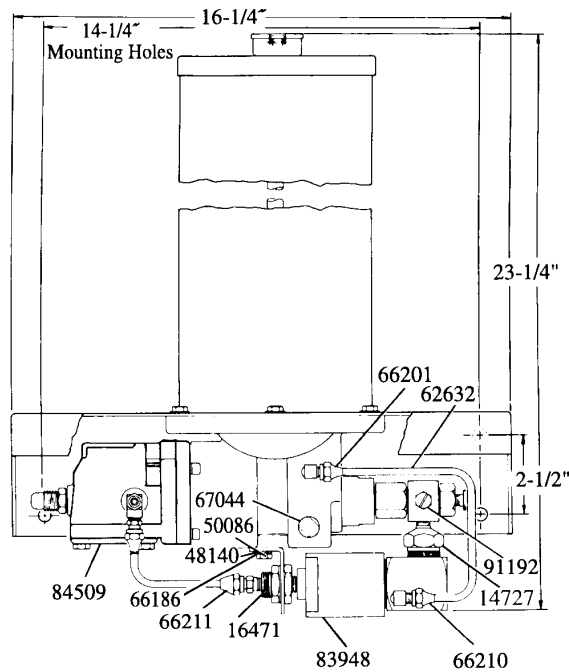

### SERVICE PARTS

Part No.	Qty.	Description	Part No.	Qty.	Description	Part No.	Qty.	Description
#*10061	1	Pump check disc	*34229	1	Packing (Nitrile)	#*83063	1	Valve slide, seat & gasket assembly
10127	1	Plug	34308	1	Gasket (Nitrile)	84508	1	Bushing, plunger & O-ring assy.
10772	1	Nipple	#*34314	1	O-ring (Nitrile)	84509	1	Pump assembly
11470	1	Cap	#*38162	1	Valve gasket (Nitrile)	#*90770	1	Trip rod
#*11471	1	Trip rod collar	40821	1	Base casting	* 91192	1	Safety unloader assembly
#*11472	1	Trip rod pin	#*45605	1	Valve guide plate	#*91331	1	Toggle plate assembly
#*11475	1	Trip shoe	48140	1	Washer	91979	1	Reservoir cap assembly
11904	1	Packing nut	48212	2	Washer	236286	1	Cover
11905	1	Packing cap	48216	1	Washer	236615	1	Muffler cover
#*11947	1	Trip sleeve	48237	1	Washer	#*236616	1	Gasket
12093	1	Check housing	50000	6	Cap screw	236833	1	Muffler
12094	1	Air piston bolt	50521	4	Screw	#*236835	4	Packing (Nitrile)
12095	1	Outlet body	51039	1	Nut	236868	6	Screw
12096	1	Outlet block	51099	1	Nut	236869	4	Screw
12551	2	pipe plug	55138	4	Spring	236870	1	Valve seat bolt
12834	1	Spring retainer	55231	1	Spring	237562	1	Air valve casting
14449	1	Tie rod	56003	1	Spring	239330	1	Viton packing assembly
14720	1	Air cylinder	56038	2	Spring	239336	1	Valve body
14271	1	Piston	62337	1	Steel tubing	#*244313	1	Seat
*14722	1	Needle	62399	1	Steel tubing	#*244359	1	O-ring (Nitrile)
*14723	1	Valve seat	62634	1	Aluminum tubing	#*245425	2	Trip rod packing nut
14727	1	Valve body	66002	1	Steel ball	246816	1	Valve cap gasket
16471	1	Support adapter	*66010	2	Steel ball	247243	1	Reservoir (Acrylic)
* 30003	1	Gasket	66200	1	Straight tube connector	#*247611	1	Gasket (Nitrile coated fiber)
#*31008	2	Gasket	66201	1	90° tube connector	360383	2	Base
31047	1	Gasket	66210	1	90° tube connector	361066	1	Bracket
31054	1	Gasket	66211	1	Straight tube connector	633102	1	Plug
31056	1	Gasket	66246	6	Lockwasher			
#*33039	1	Gasket	67011	1	Tee			
34090	1	Packing (Nitrile)	67044	1	Pipe plug			
*34110	1	Packing (Nitrile)	68797	1	Plug button			
*34158	1	Gasket (Neoprene)	68849	1	Strainer			
34165	1	O-ring (Nitrile)	68850	1	Filler cap			

\*Recommended Service Parts Inventory. #Included in 246415 Repair Kit. © - Indicates Change

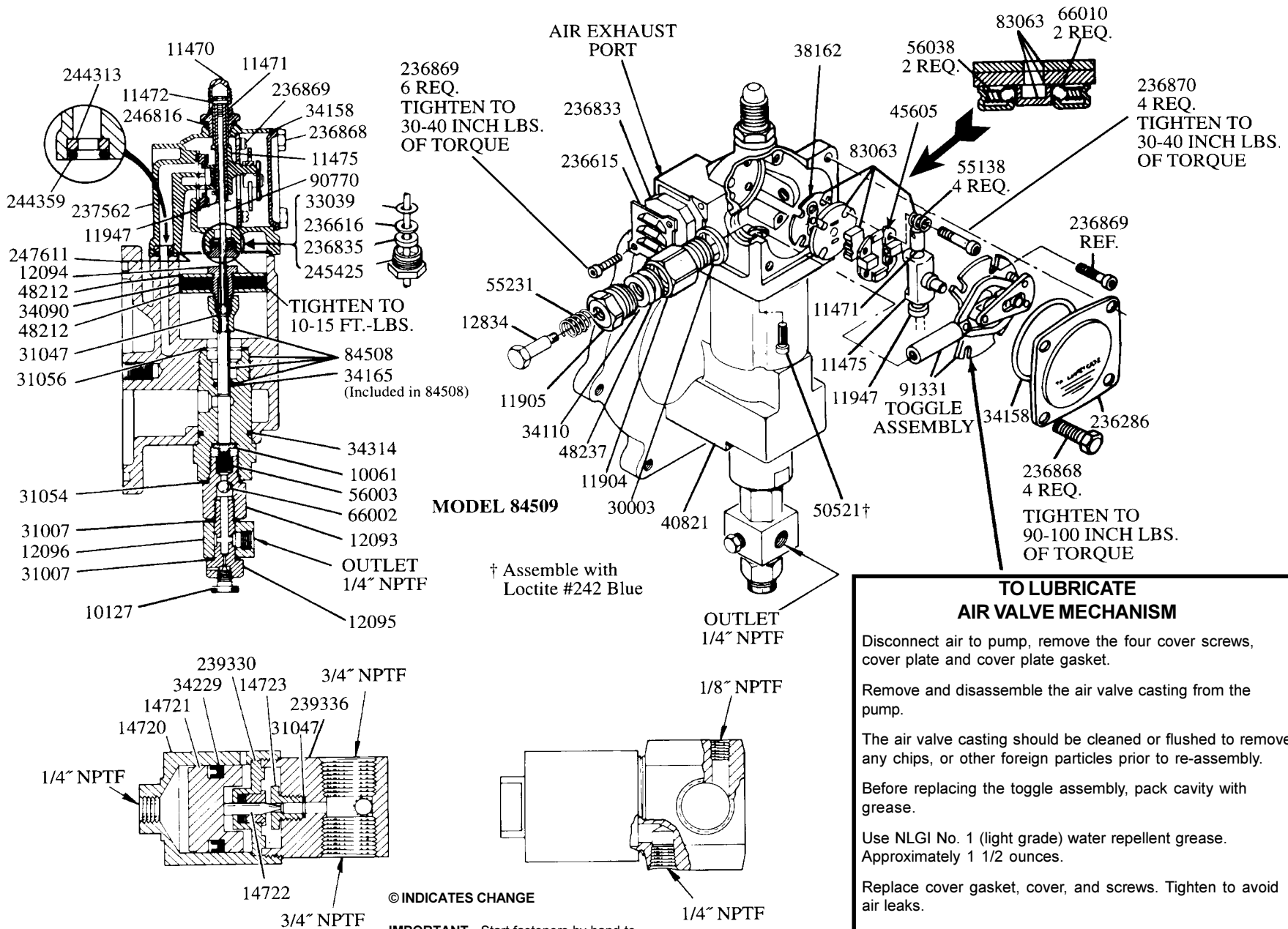

83948 VENT VALVE

---

## INSTRUCTIONS FOR PUMP USING 85209 CONTROL PANEL

### TO PRIME SYSTEM

#### SUPPLY LINES:

After pump reservoir has been filled with recommended lubricant, loosen all plugs in dead ends of injector manifolds and supply lines. Turn vent plug in pump counter-clockwise one complete turn. Depress manual lube pushbutton on door to start pump. Operate pump until lubricant bleeds around vent plug to expel air pockets trapped between the pump and the supply line connection. Tighten vent plug. Continue operating pump until lubricant flows around any plug. Tighten plug. Repeat this procedure until all plug openings are tight and supply lines are primed. Turn off power to reset controller.

#### IMPORTANT:

Refer to Owner/Operator Manual C8 259 to program controller 85209.

#### FEEDER LINES:

Fill each feed line with lubricant before connecting lines to outlets of injectors and bearings. This will prevent having to cycle each injector to fill the feed line between injector and bearing.

#### INJECTORS:

Check the injectors for proper operation by observing the movement of the indicator stems.

#### OPERATION:

When Model 85530 times out it will initiate a lube cycle. The air solenoid is energized to deliver air to the pump and air to the vent valve. Pump begins dispensing lubricant through injectors to the bearings. When all bearings have received lubricant, pressure rises in system to actuate pressure switch. When pressure switch actuates, the control is reset to de-energize solenoid valve cutting off air to pump and vent valve. Pump stops, pressure vents and pressure switch de-actuates. Control begins timing toward next lube event.

---

## INSTRUCTIONS FOR PUMP USING 83820 TIME CONTROL

### TO PRIME SYSTEM:

#### SUPPLY LINES:

After pump reservoir has been filled with recommended lubricant, loosen all plugs in dead ends of injectors manifolds and supply lines. Turn vent plug in pump counter-clockwise one complete turn. Set the delay relay to its maximum position (Refer to Service Manual Section C8, Page 133 Series). Depress push button on top of time control to start pump. Operate pump until lubricant bleeds around vent plug to expel air pockets trapped between the pump and the supply line connection. Tighten vent plug. Continue operating pump until lubricant flows around any plug. Tighten plug. Repeat this procedure until all plug openings are tight and supply lines are primed. Open line switch to shut off pump.

#### IMPORTANT:

Reset the delay relay to desired interval (Refer to System Planning Manual).

#### INJECTORS:

Check injectors for proper operation by observing the movement of the indicator stems.

#### OPERATION

The timer (runs constantly when current is on), drives a cam which has lobes for the desired lubrication cycle frequency (Refer to Service Manual Section C8, Page 133 Series). Lobes engage the micro-switch lever arm to activate the switch, closing the circuit to open the 3-way solenoid air valve permitting air to operate the pump. The pump discharges lubricant through the supply line to the injectors. After the injectors operate (discharge lubricant to the bearings), pump continues to build up lubricant pressure in the supply line until sufficient to operate the pressure control which moves a switch plate, breaking the circuit to the 3-way solenoid air valve, shutting off the air to the pump. Injectors automatically re-charge with lubricant and system is ready for the next lubrication cycle.

The pressure control is factory set for 2,500 psi and must be converted for use in an 850 psi system. For low pressure conversion:

- 1) Loosen locknut.
- 2) Turn the housing counter-clockwise to remove from pressure control.
- 3) Replace 55277 Spring with 55279 Low Pressure Spring (included with 83820 Time Control).
- 4) Reassemble pressure control, turning housing clockwise to 1,000 psi max. setting.
- 5) Tighten Locknut.

---

#### VENT VALVE:

The 83948 Vent Valve is operated by compressed air from the same source which operated the pump. When pump is in operation, air pressure keeps the vent valve closed and lubricant is directed through the outlet and to the injectors. When air to the pump is shut off, vent valve opens and supply line pressure vents back into the reservoir.

#### SAFETY UNLOADER:

91192 Safety unloader is provided at the pump outlet to prevent the build-up of dangerously high lubricant pressure in the system. It is factory set to open at approximately 1,100 psi to 1,300 psi.

**NOTE:** Safety unloader requires no adjustment and should not be tampered with.

#### WHAT TO DO IF:

**Pump loses prime:** Check lubricant supply.

10127 Vent Plug is provided at the pump outlet for expelling air which may be pocketed in the lubricant. If pump operates continuously without discharging lubricant, it is an indication that the pump has lost its prime. Loosen the vent plug one turn until trapped air is pumped out. If pump continues to operate without discharging lubricant, 10061 Pump Check and 66002 Steel Ball may be fouled. Remove and clean checks and check seats.

The 83948 Vent Valve may also be fouled. Foreign material may prevent 14722 Needle from seating properly or 14723 Valve Seat may be worn or damaged. Clean or replace parts.

Failure of injectors to cycle can also be caused by a leak in the supply line. Examine lines and connections.

**Pump fails to operate:** Check air supply.

---

### RETAIN THIS INFORMATION FOR FUTURE REFERENCE

When ordering replacement parts, list: Part Number, Description, Model Number and Series Letter.  
LINCOLN provides a Distributor Network that stocks equipment and replacement parts.