

FOR TYPES SL-4 AND SL-31
INJECTOR MANIFOLDS

INJECTOR CHART

Type	Adj. Output Cu. In.	Operating Pressure	Working Pressure	Vent Pressure	Lubricant*
SL-32	.001 to .008	1200 to 3500 p.s.i.	1500	200	grease or oil
SL-33	.001 to .003	1200 to 3500 p.s.i.	1500	200	grease or oil
SL-42	.001 to .003	750 to 1000 p.s.i.	850	150	oil only

* Grease not to exceed N.L.G.I. #1

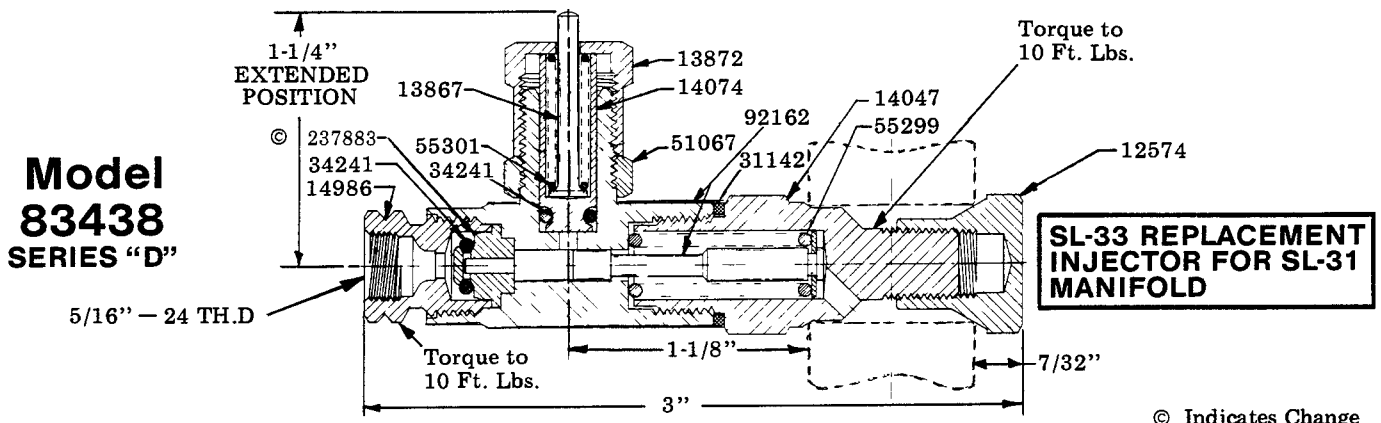
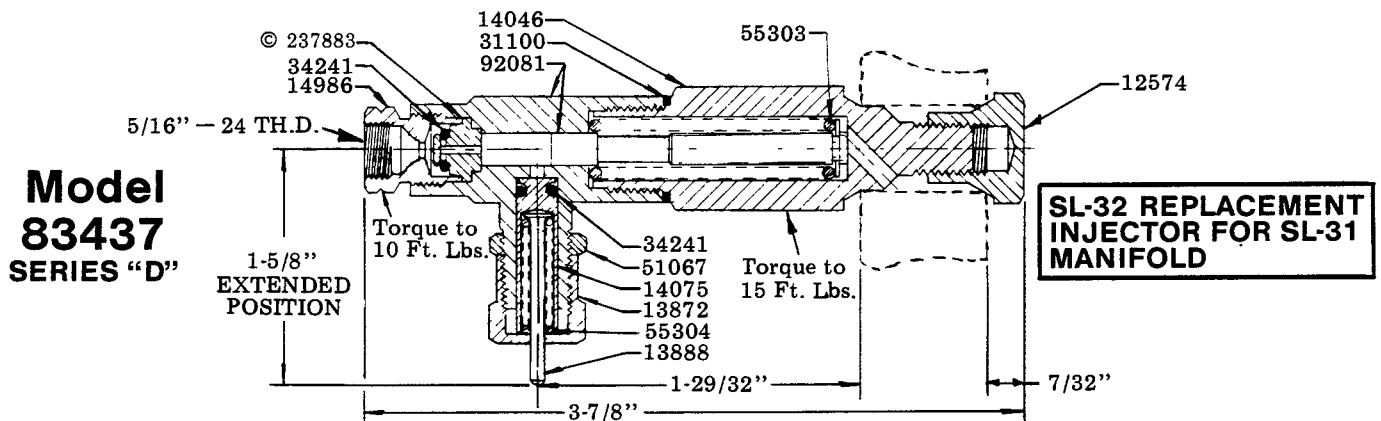
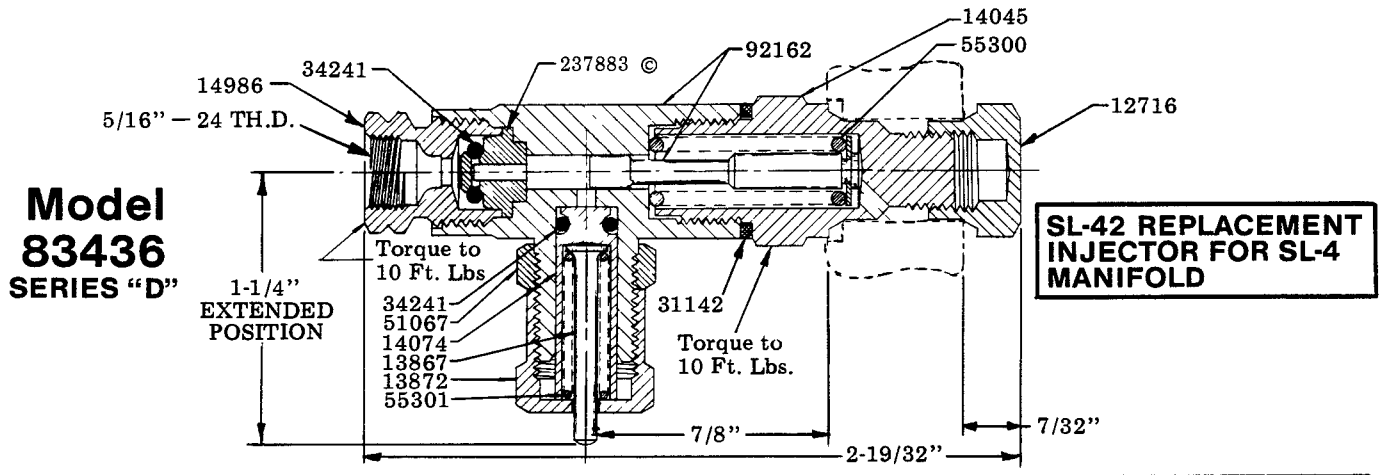

© Indicates Change

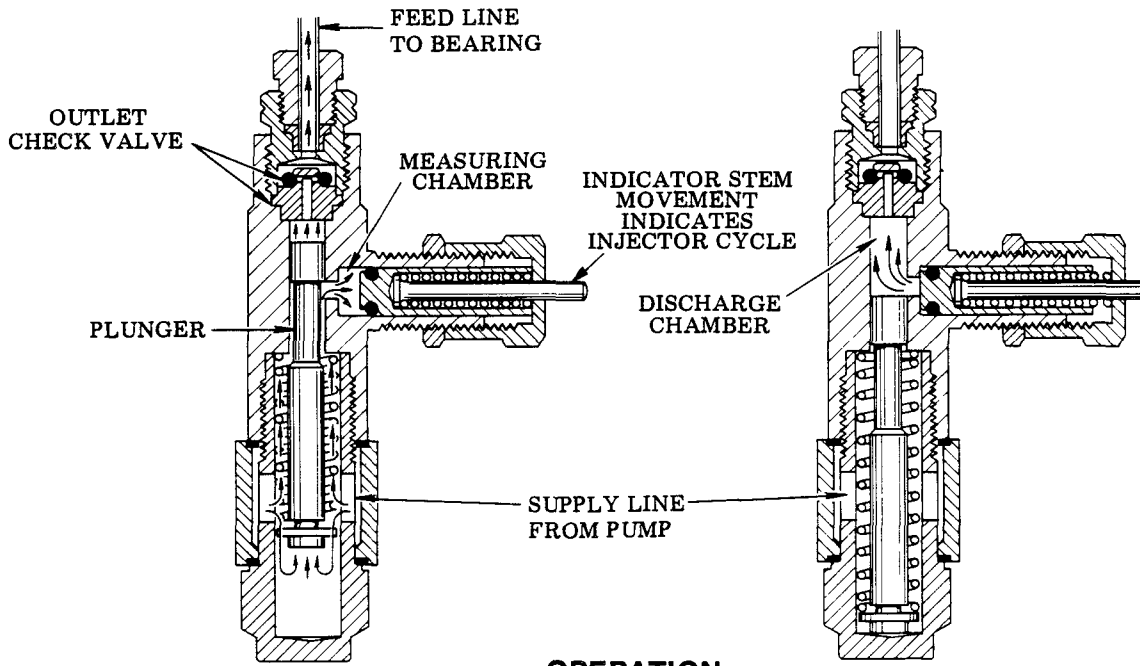

SUPPLY LINE UNDER PRESSURE

Lubricant pressure moves plunger to force lubricant in the discharge chamber through the outlet check valve to the feed line.

Lubricant from supply line charges the measuring chamber.

SUPPLY LINE VENTED

Plunger returns to normal position after supply line is vented, connecting measuring chamber to the discharge chamber. Flow from feed line is blocked by the outlet check valve.

Lubricant is automatically transferred from measuring chamber to discharge chamber.

INJECTOR ADJUSTMENT

Injector output is controlled by the position of the indicator cap which limits the travel of the packing retainer.

With the indicator cap hand tightened against its stop, the lubricant output is decreased to a minimum.

When the injector has been adjusted for the proper lubricant output, the lock nut is tightened against the face of the indicator cap.

Model 83436 and Model 83438 injectors permit a maximum of .003 cu. in. to be dispensed when the indicator cap is retracted two full turns.

Model 83437 injector permits a maximum of .008 cu. in. to be dispensed when the indicator cap is retracted five full turns.

Retracting the indicator cap beyond this point will not increase the lubricant output.

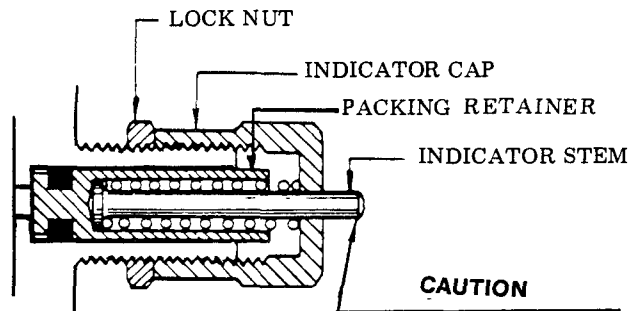

CAUTION

INDICATOR CAP MUST NOT EXTEND BEYOND RETRACTED POSITION OF INDICATOR STEM

SERVICE PARTS

Part	Description	Part	Description	Part	Description
12574	Manifold Nut	14074	Packing Retainer	55299	Spring
12716	Manifold Nut	14075	Packing Retainer	55300	Spring
13867	Injector Indicator	14986	Outlet Body	55301	Spring
13872	Injector Cap	237883	Check Seat	55303	Spring
13888	Injector Indicator	31100	Gasket	55304	Spring
14045	Injector Inlet Adaptor	31142	Gasket	92081	Body & Plunger Assembly
14046	Injector Inlet Adaptor	34241	"O" Ring	92162	Body & Plunger Assembly
14047	Injector Inlet Adaptor	51067	Lock Nut		

RETAIN THIS INFORMATION FOR FUTURE REFERENCE

When ordering replacement parts, list: Part Number, Description, Model Number, and Series Letter.

LINCOLN provides a Distributor Network that stocks equipment and replacement parts.