

RATIO	LUBRICANT OUTPUT (CU. IN.)	RESERVOIR CAPACITY	AIR INLET	LUBRICANT OUTLET	LUBRICANT OPERATING PRESSURE (PSI)			
					TYPE OF SYSTEM	MINIMUM	MAXIMUM	RECOMMENDED
25:1	* 2.15	4 lb. (120 cu. in.)	1/4" NPT Female	1/4" NPT Female	SL-1	1,850 with 75 PSIG Air	3,500 with 140 PSIG Air	2,500 with 100 PSIG Air
					SL-32 SL-33	1,200 with 50 PSIG Air	3,500 with 140 PSIG Air	1,500 with 60 PSIG Air

*Based on Lubricants that are free from entrapped air. Lubricants that are aerated will reduce output of pump.

The 83834 Pump is used as the Pumping Unit for a Centralized Lubrication System having a Single Line Circuit of SL-1, SL-32, or SL-33 Injectors. Dispenses grease up through NLGI No. 1.

It is an air-operated, single-stroke pump requiring air for both forward and return stroke and discharges *2.15 cu. in. of lubricant into the circuit for each pump stroke (Lubrication Cycle).

The total quantity of lubricant needed for the lubrication cycle of the system must not exceed the amount of lubricant discharged per pump stroke.

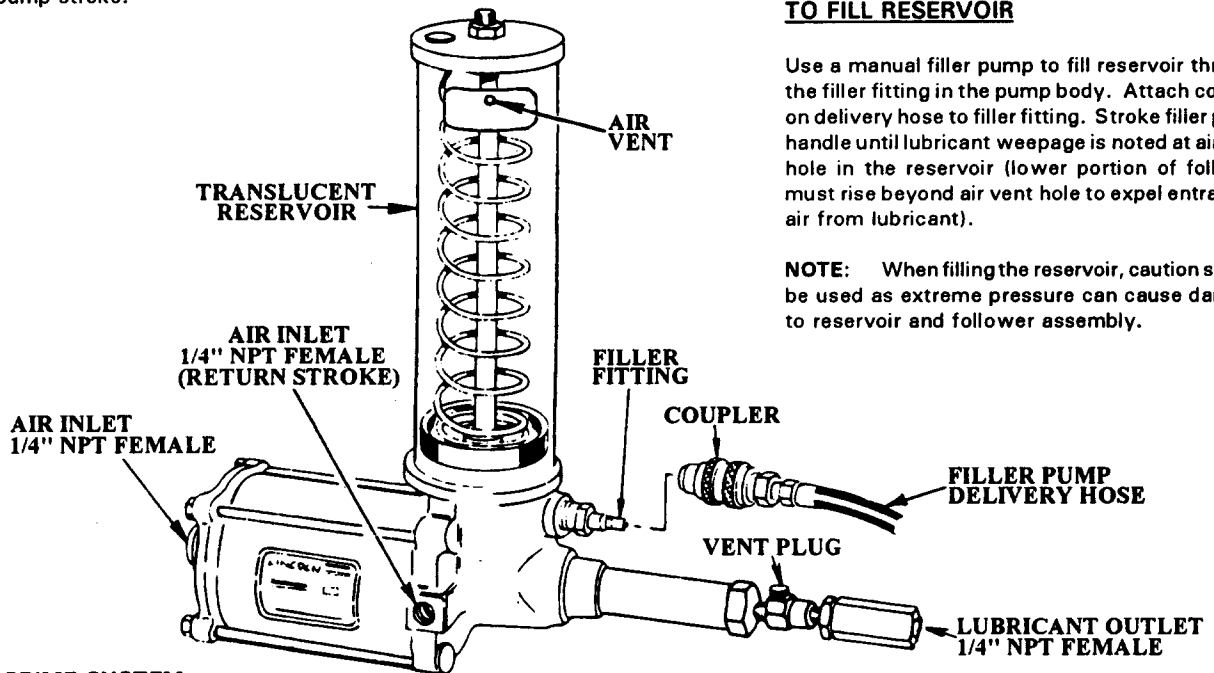

TO FILL RESERVOIR

Use a manual filler pump to fill reservoir through the filler fitting in the pump body. Attach coupler on delivery hose to filler fitting. Stroke filler pump handle until lubricant weepage is noted at air vent hole in the reservoir (lower portion of follower must rise beyond air vent hole to expel entrapped air from lubricant).

NOTE: When filling the reservoir, caution should be used as extreme pressure can cause damage to reservoir and follower assembly.

TO PRIME SYSTEM

SUPPLY LINES: After pump reservoir has been filled with recommended lubricant, turn vent plug counter-clockwise one complete turn and operate pump until lubricant flows freely from opening in vent plug to expel air pockets trapped between the pump and the supply line connection. Tighten vent plug. Remove all plugs in dead ends of the injector manifolds and supply lines. Operate pump until lubricant flows from any plug opening. Close opening with plug. Continue operating pump until lubricant flows from another plug opening. Repeat this procedure until all supply lines are primed and plug openings closed.

FEEDER LINES: Fill each feed line with lubricant before connecting lines to outlet of injectors and bearings. This will prevent having to cycle each injector for every inch of feed line between injector and bearing.

INJECTORS: Check each injector for proper operation. Injector stem moves when injector discharges lubricant to bearing. This may require cycling system several times. After checking injectors for operation, adjust injectors for the volume required for each bearing.

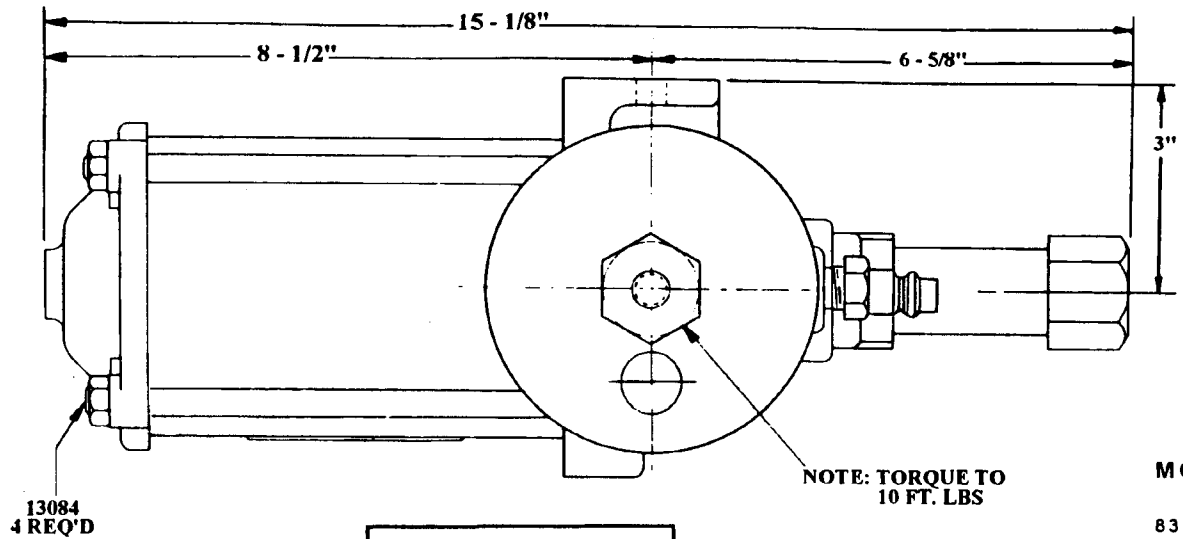

MODEL 83671

83671 Low Level Cut-Off Kit may be used as an alarm or signal device when lubricant drops below an acceptable level.

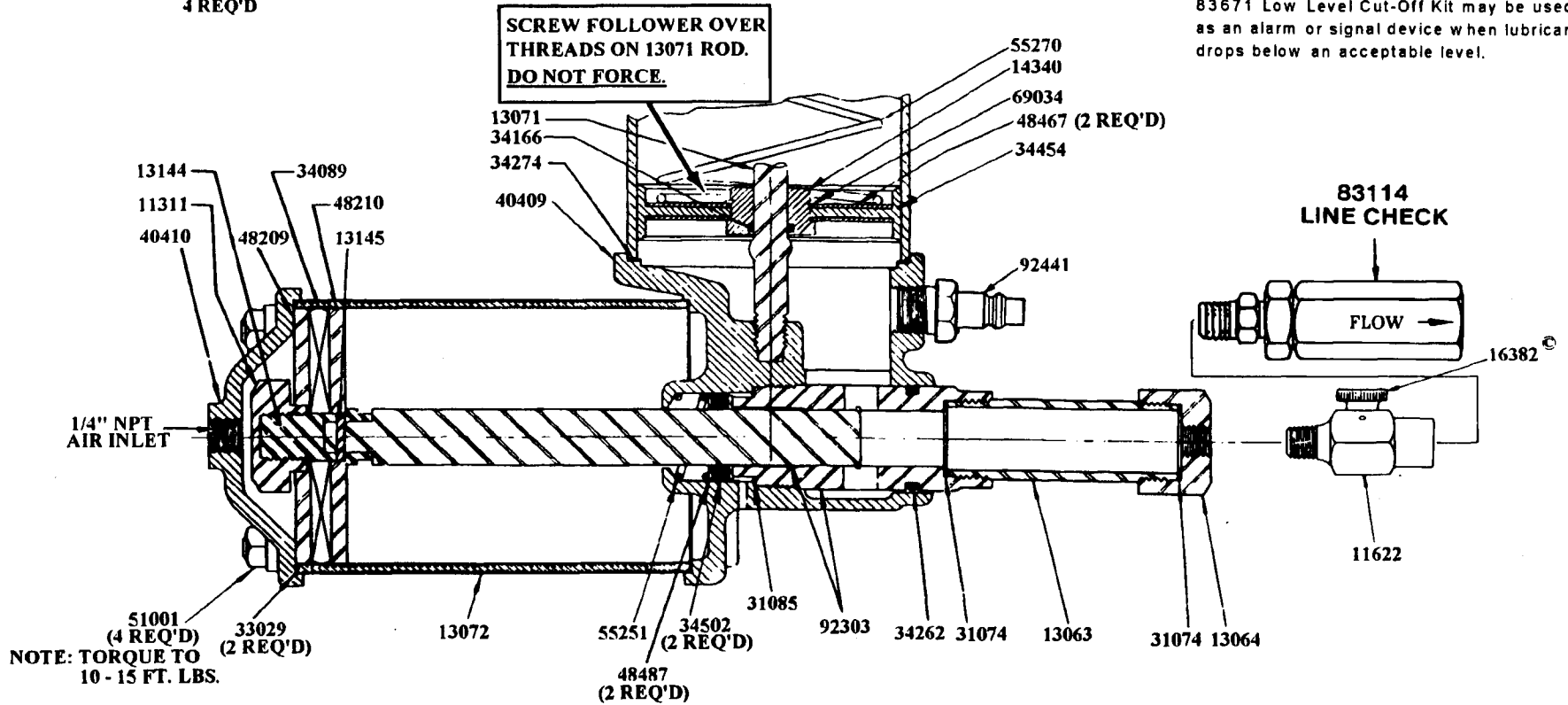

Model 83834
AIR OPERATED SINGLE STROKE
GREASE PUMP

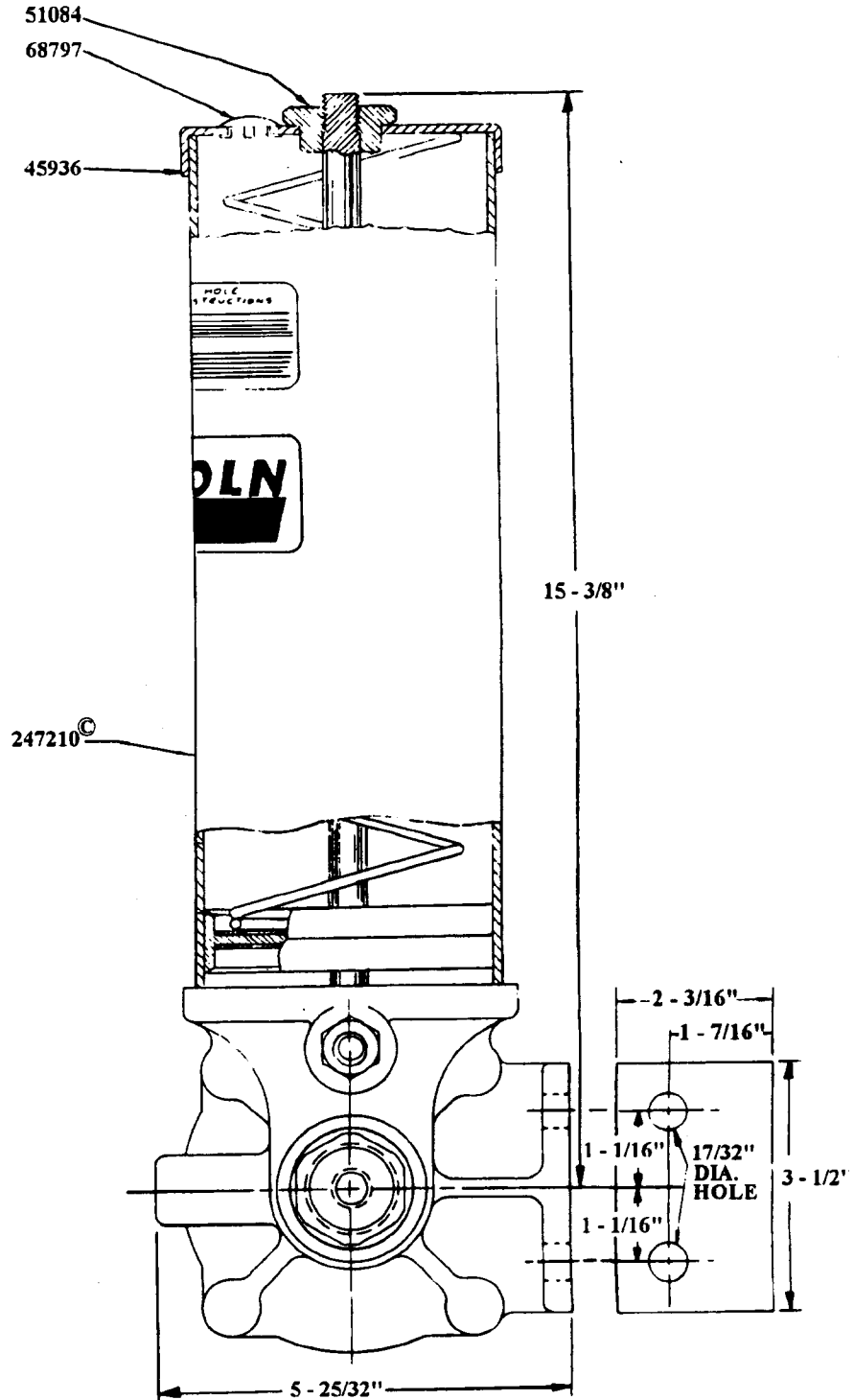

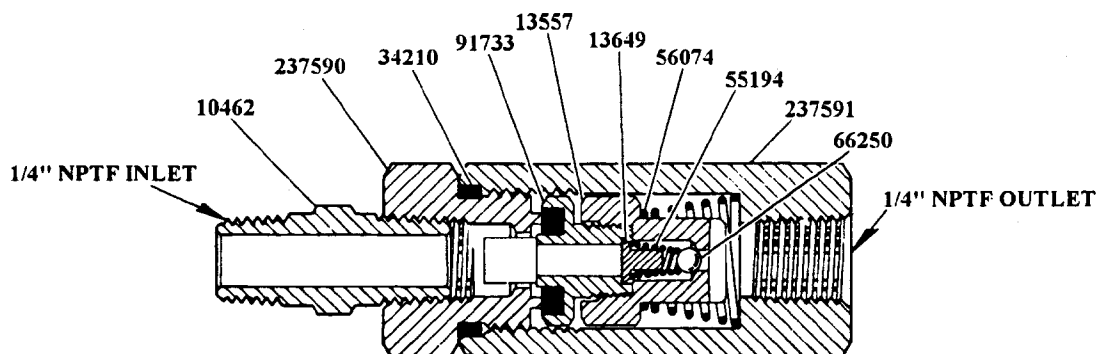

**8314
LINE CHECK**

TO CLEAN LINE CHECK 83114

Remove 91733 Check and examine packing for presence of foreign particles. If packing is damaged, replace 91733 Check.

Remove 66250 Ball Check, 55194 Spring and 13649 Ball Stop from 13557 Check Retainer. Examine for presence of foreign particles. Clean thoroughly.

WHAT TO DO IF: PUMP LOSES PRIME - Check lubricant supply.
 SYSTEM FAILS TO CYCLE - and calculated system planning has been followed - Lubricant is leaking by packing of 91733 Check or the 66250 Check. Failure of injectors to cycle can also be caused by a leak in supply lines. Examine supply lines and connections.
 PUMP FAILS TO OPERATE - Check air supply.

SERVICE PARTS

PART NO.	QTY	DESCRIPTION	PART NO.	QTY	DESCRIPTION	PART NO.	QTY	DESCRIPTION
10462	1	Nipple	*33029	2	Gasket	51084	1	Nut
11311	1	Piston nut	*34089	1	Packing (Nitrile)	55194	1	Spring
11622	1	Outlet Body	*34166	1	O-ring (Nitrile)	55251	1	Spring
13063	1	Pump tube	*34210	1	O-ring (Nitrile)	55270	1	Spring
13064	1	Outlet	*34262	1	O-ring (Nitrile)	56074	1	Spring
13071	1	Tie rod	*34274	1	Gasket	*66250	1	Steel ball
13072	1	Air cylinder	*34454	1	Follower Packing (Nitrile)	68797	1	Plug button
13084	4	Tie rod	34502	2	Packing (Nitrile)	69034	1	Retaining ring
13144	1	Packing stud	40409	1	Body casting	83114	1	Line check assembly
13145	1	Pin	40410	1	Cylinder cap	*91733	1	Check
13557	1	Check retainer	45936	1	Cover cap	92303	1	Bushing & plunger
13649	1	Ball stop	48209	1	Washer	92441	1	Filler fitting
14340	1	Bushing	48210	1	Washer	237590	1	Check seat
©16382	1	Vent plug	48467	2	Washer	237591	1	Check body
*31074	2	Gasket	48487	2	Washer	©247210	1	Reservoir (Acrylic)
*31085	1	Gasket	51001	4	Nut			

* Recommended service parts inventory.

RETAIN THIS INFORMATION FOR FUTURE REFERENCE

When ordering replacement parts, list: Part Number, Description, Model Number and Series Letter.
 LINCOLN provides a Distributor Network that stocks equipment and replacement parts.