

# PROGRAM TIMER

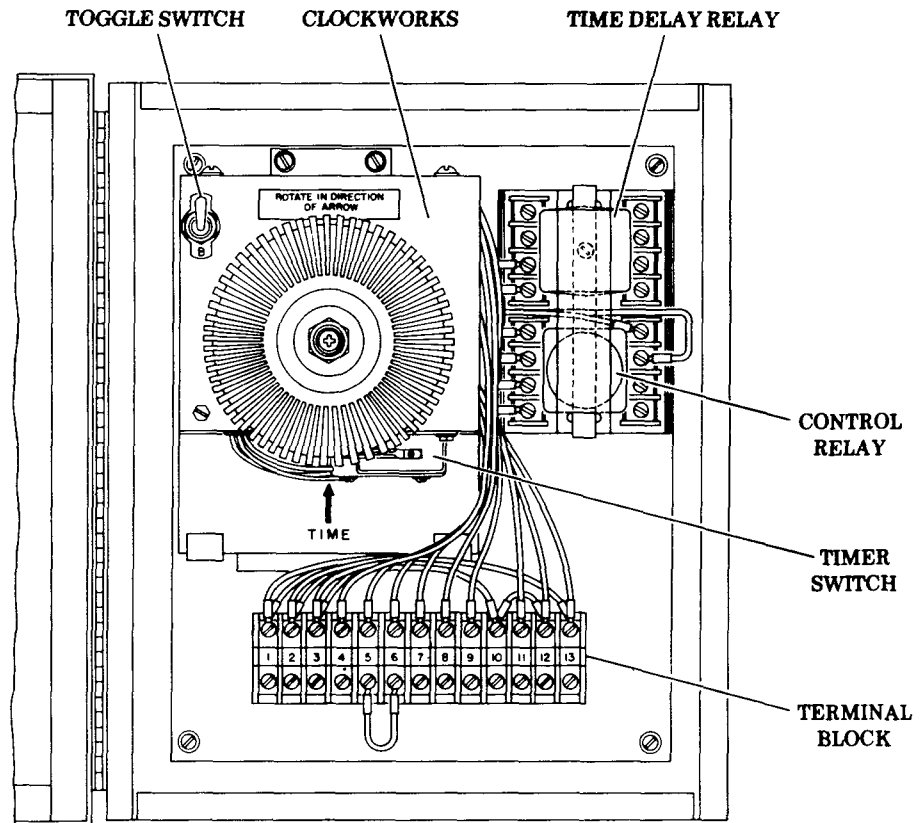

# Model 84068

# Series "B"



Whenever possible the master control panel should be interlocked with the starter controls of the machine being lubricated to be sure the machine will be lubricated when it is operated.

Timer adjusts from 2-1/2 minutes to 4 hours at 115 volts, 60 hertz (3 minutes to 4-3/4 hours at 95 volts, 50 hertz).

It is necessary that a monitor box, horn, light or a warning device be wired into the master control circuit to obtain maximum protection in the form of a signal when the Centro-Matic system is not operating properly.

## ELECTRICAL SPECIFICATIONS

The 84068 is designed for use on 115 volts, 60 hertz, single phase but will operate on 95 volts ( $\pm 15\%$ ), 50 hertz at reduced speed of timing motor. Switching capacity 5 amps. Maximum power required is 7.5 volt-amps. (Does not include externally connected signal devices.)

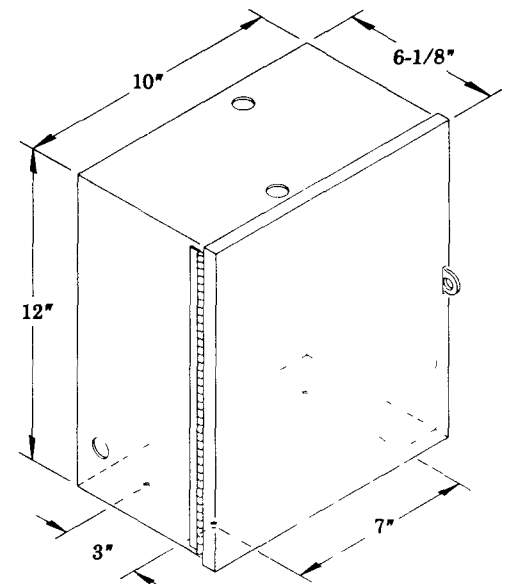

**LINCOLN ST. LOUIS**

4010 GOODFELLOW BLVD • ST LOUIS MO 63120 • (314) 383 5900



A DIVISION OF  
**McNEIL**  
CORPORATION

SECTION - C8  
PAGE - 138A

## SETTING CYCLE FREQUENCY

The electric clockworks runs constantly when current is on. The equally spaced clips, pushed into the inner groove of the program disc, control the frequency of lube cycles. As the program disc rotates, the clips contact and depress the arm of the timer switch. The closed switch completes the circuit to energize the solenoid air valve or motor starter to start pump. The rotating program disc releases the contact when the clip moves off the switch arm.

TIME INCREMENTS FOR EQUALLY SPACED CLIPS

	NUMBER OF CLIPS	1	2	3	4	6	8	12	16	24	32	48	96*
115 VOLTS 60 HERTZ	MINUTES	240	120	80	60	40	30	20	15	10	7.5	5	2.5
95 VOLTS 50 HERTZ	MINUTES	288	144	96	72	48	36	24	18	12	9	6	3

\*48 extra 45952 Clips must be ordered separately.

## INSTRUCTIONS

Select desired time from above chart. Move only number of clips indicated to inner groove.

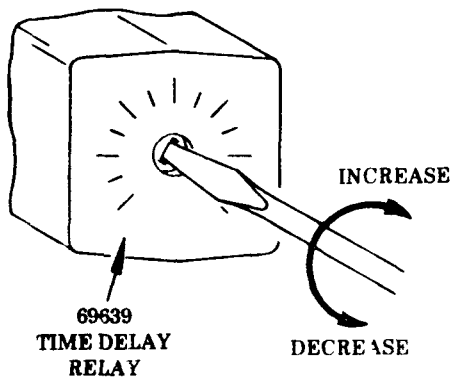
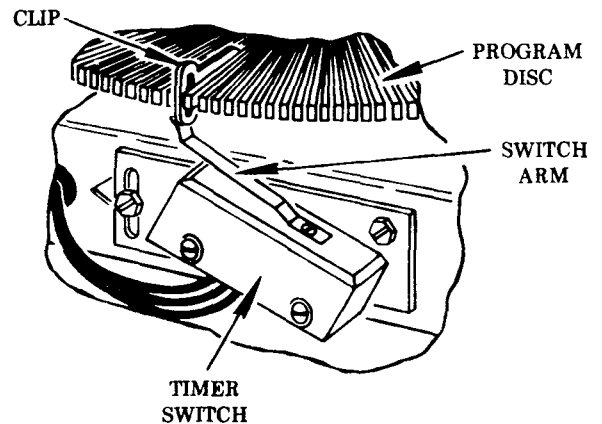
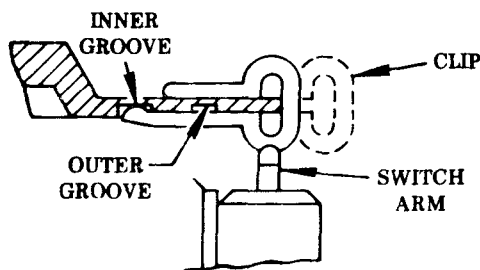

### TO ADJUST TIME DELAY RELAY

The time delay relay has an adjustable delay interval of 3 seconds to 240 seconds (4 mins.).

To adjust relay for desired interval, insert screwdriver into slot of the relay and turn clockwise to increase time delay or counter-clockwise to decrease time delay.

## REMOTE PUSHBUTTON SYSTEM

One or more pushbutton stations can be installed remotely from the program timer so that the Centro-Matic system can be conveniently operated between the clocked lubrication cycles.

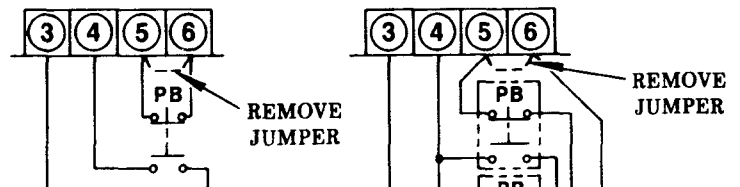

SINGLE REMOTE PUSHBUTTON  
MANUAL LUBE STATION

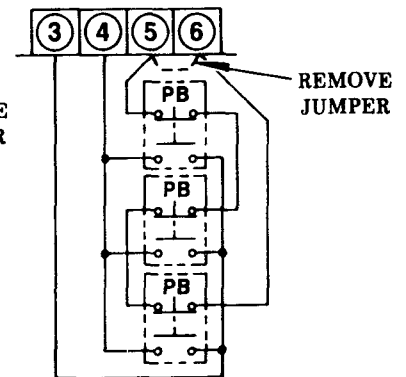

MULTIPLE REMOTE PUSHBUTTONS  
MANUAL LUBE STATIONS

## MANUAL LUBRICATION CYCLE

### PRE-LUBE CYCLE

When power is turned on with toggle switch in "A" position and timer switch in the normal position (switch arm not depressed), a circuit through a closed contact of the toggle switch and magnetic relay starts the pump.

### LUBRICATION CYCLE CONTROLLED BY THE TIMER

Toggle switch in "B" position. Circuits to magnetic relay are only made when timer switch is active (switch arm depressed).



### TO OPERATE THE SYSTEM AT ANY TIME BETWEEN THE CLOCKED LUBRICATION CYCLES

Rotate the program disc clockwise by hand through one clip.

# MODEL 84068 PROGRAM TIMER

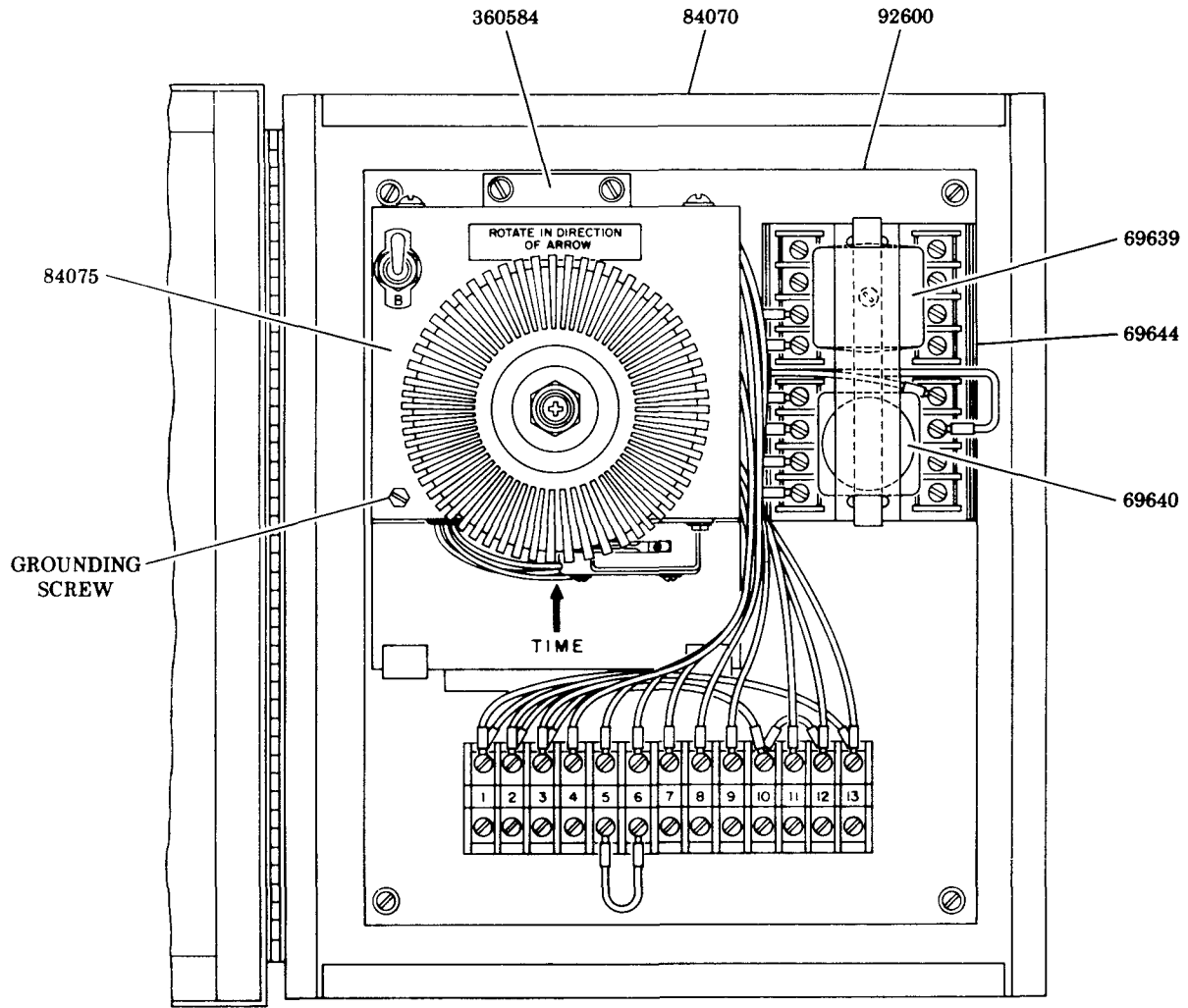

## 84075 CLOCKWORKS

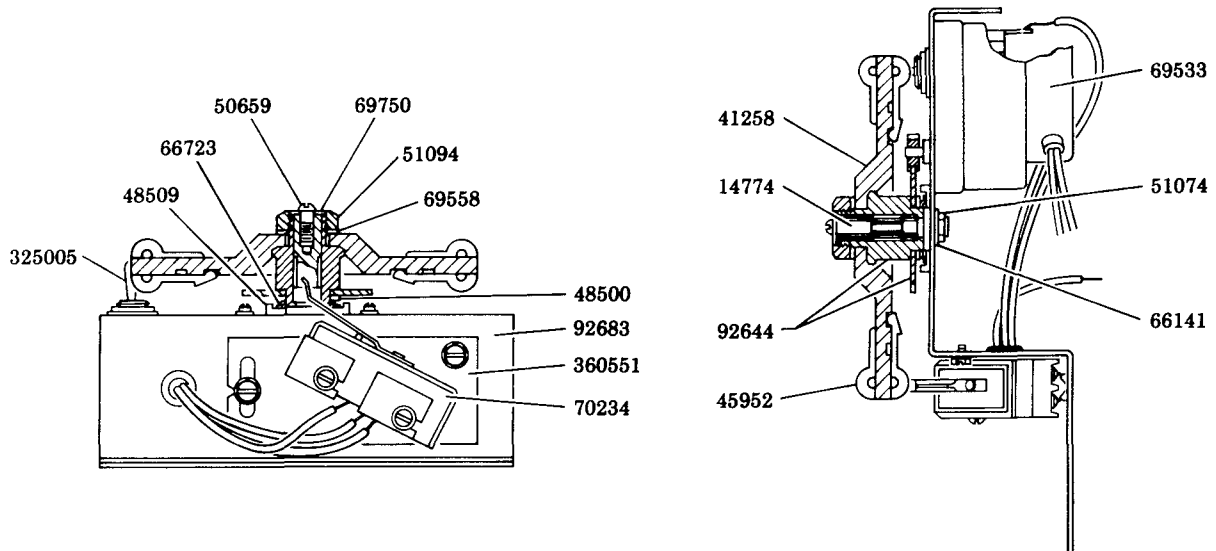

## ELEMENTARY DIAGRAM

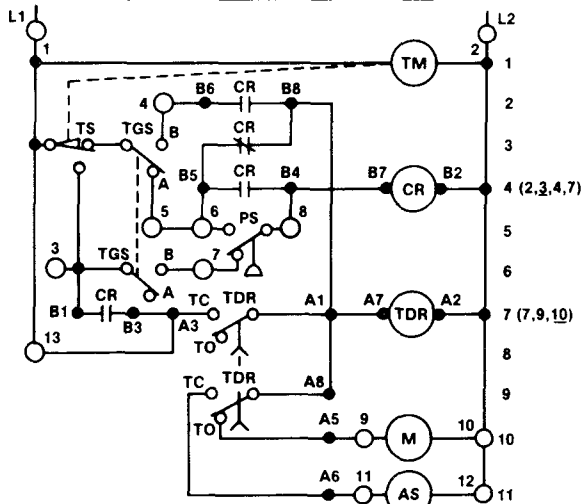

NOTE: Numbered open circles on diagrams identify corresponding numbered terminals on timer.

## POSITION DIAGRAM

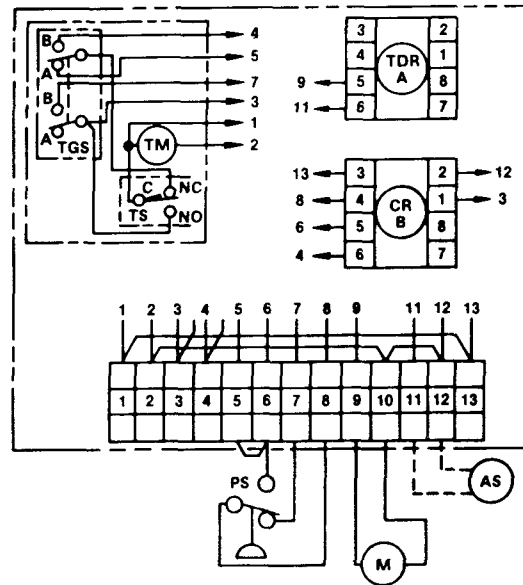

## SEQUENCE OF OPERATION

- (1) Toggle Switch (TGS) in position "A", power "on" energizes Time Delay Relay (TDR) coil, line 7, through contacts Timer Switch (TS), TGS and Control Relay (CR), line 3, Motor Starter or Solenoid Air Valve (M) and Solenoid Vent Valve (SOL) (when used) through TDR, line 10. TDR begins to time out and pump delivers lubricant.
- (2) Pressure rises actuating Pressure Switch (PS) contacts, line 5, to energize CR coil, line 4, opening CR contacts, line 3, and closing CR contacts, line 4. TDR resets, pump stops, pressure vents, but CR remains energized TS, line 3, is actuated by Timer Motor (TM) to de-energize CR coil. Next lube cycle starts when TM releases TS. Operation follows steps 1 and 2 above.
- (3) TGS in position "B", TS, line 3, is actuated by TM, energizing CR coil, line 4, through "B" of TGS and PS, line 6. When TM releases TS, CR coil is held energized through CR contacts, line 7, and PS, line 6. TDR coil is now energized through "B" of TGS, line 3, and CR contacts, line 2. M and SOL (when used) are also energized through TDR contacts, line 10. TDR begins to time out and pump delivers lubricant. Pressure rises in lube supply line.
- (4) PS actuates, de-energizing CR coil, line 4. CR contacts, line 2, open, de-energizing TDR and pump stops, pressure vents and TDR resets. Operation follows as in 3 and 4.
- (5) If TDR times out before PS actuates, TDR contacts, line 7, close, holding TDR timed out. TDR contacts, line 9, close, energizing Alarm Signal (AS), line 11, and TDR contacts, line 10, open, stopping pump. Power must be interrupted to release TDR coil and restore system operation.

CODE	PART	DESCRIPTION
TM	PART OF	TIMER MOTOR
TS	84075	TIMER SWITCH
TGS	TIMER	TOGGLE SWITCH
TDR	69639	TIME DELAY RELAY
CR	69640	CONTROL RELAY
PS	69630	PRESSURE SWITCH
M	*	MOTOR STARTER
	69531†	OR SOL. AIR VALVE
SOL	68307††	SOL. VENT VALVE
AS	*	ALARM SIGNAL

\* Supplied by customer.

† Used on Model 84067.

†† Used on Model 84066.

## SERVICE PARTS

\*Recommended service parts inventory.

PART	QUAN.	DESCRIPTION	PART	QUAN.	DESCRIPTION	PART	QUAN.	DESCRIPTION
14774	1	Axle	66723	1	Spring washer	*84075	1	Clockworks
41258	1	Index wheel	*69533	1	Timing motor	92600	1	Mounting panel
*45952	48	Clip	69558	1	Lockwasher	*92644	1	Bearing & gear
48500	1	Washer	*69639	1	Time delay relay	92683	1	Mounting bracket
48509	1	Cup washer	*69640	1	Control relay	*325005	1	Toggle switch
50659	1	Screw	69644	1	Octal relay socket	360551	1	Switch bracket
51074	1	Nut	69750	1	Brass washer	360584	1	Bracket
51094	1	Nut	*70234	1	Micro-switch			
66141	1	Lockwasher	84070	1	Enclosure			

### RETAIN THIS INFORMATION FOR FUTURE REFERENCE

When ordering replacement parts, list: Part Number, Description, Model Number, and Series Letter.

LINCOLN ST. LOUIS provides a Distributor Network that stocks equipment and replacement parts.

A list of Authorized Service Departments will be furnished upon request.