

SPECIFICATIONS

FOR OFF-HIGHWAY MINING TRUCKS

Ratio	Lubricant Output (cu. in.)		Reservoir Capacity	Air Inlet	Lube Outlet	Lubricant Operating Pressure (PSI)			
	Per Cycle	Per Min.				Type of System	Minimum	Maximum	Recommended
40:1	* 11	12	12 lbs.	Ⓒ 1/4" NPTF	3/4" NPTF	SL-1	1850	3500	2500
						SL-11			
						SL-32	1200	3500	1500
						SL-33			

* Based on lubricants that are free of entrapped air. Lubricants that are specifically aerated will reduce the output of the pump

Ⓒ Indicates change

WARNING
DO NOT OPERATE THIS UNIT WITH COMBUSTIBLE GAS.

TYPICAL INSTALLATION

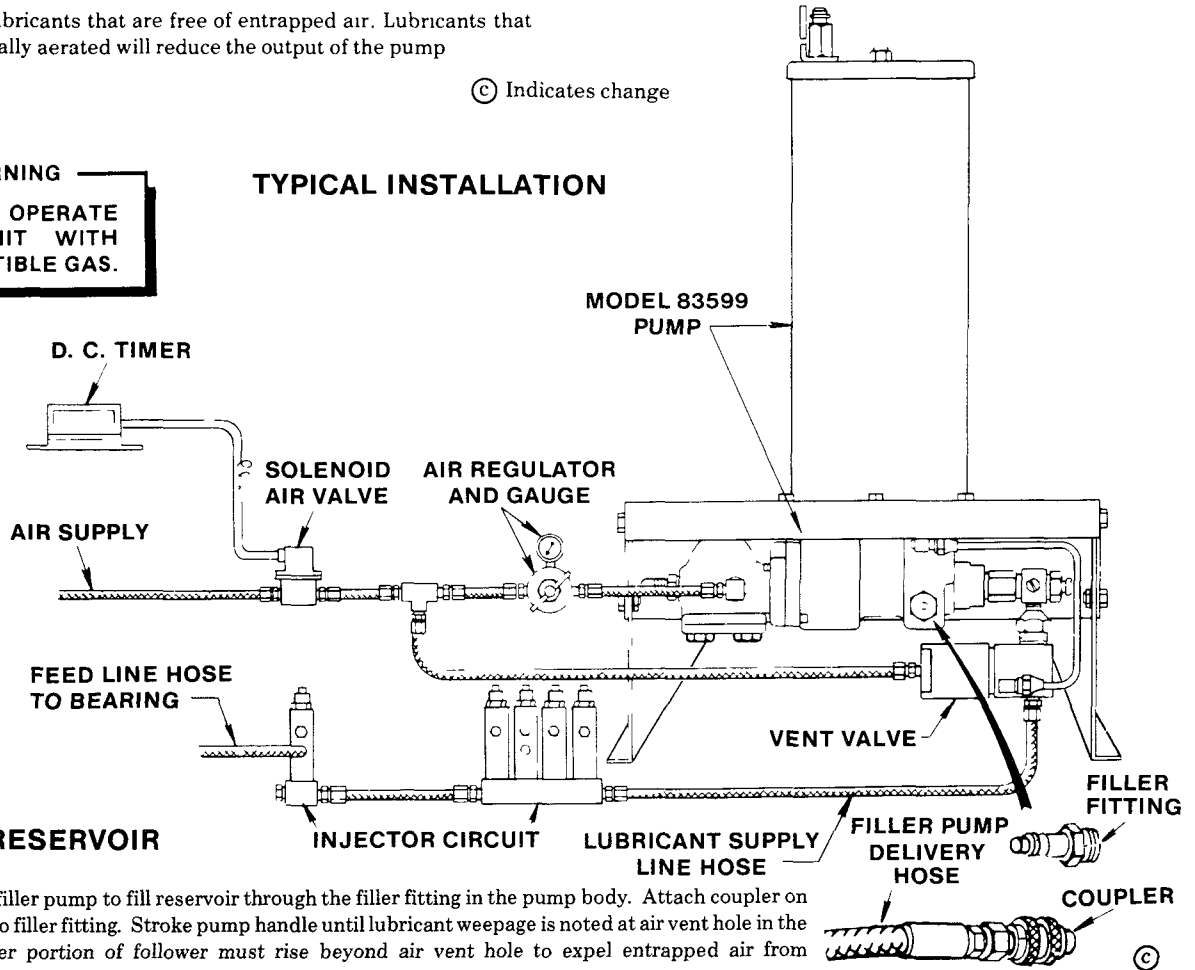

TO FILL RESERVOIR

Use a manual filler pump to fill reservoir through the filler fitting in the pump body. Attach coupler on delivery hose to filler fitting. Stroke pump handle until lubricant weepage is noted at air vent hole in the reservoir (lower portion of follower must rise beyond air vent hole to expel entrapped air from lubricant).

NOTE: When filling the reservoir, caution should be used as extreme pressure can cause damage to reservoir and follower assembly.

OPERATION

The operation of the 83599 Pump is fully automatic, controlled by a 12 or 24 volt D C electric timer and electric operated solenoid air valve. As the truck operates, the timer periodically turns on a switch which energizes the solenoid air valve. The solenoid air valve opens, and admits regulated air to the Centromatic Pump, closing the vent valve. The pump begins to operate, delivering lubricant through the supply lines to each lubricant injector.

As the pump builds up pressure, a measured amount of lubricant is dispensed to the bearings by each injector. After all injectors have cycled, lubricant pressure rises rapidly to 2400 psi with air regulated to 60 psi, and the pump stalls against pressure.

The timer switch contact is broken, and the solenoid air valve is de-energized, shutting off the air supply. Air then exhausts from the pump and vent valve assembly. As air is relieved, the vent valve opens and lubricant pressure in the system vents back through the supply line to the lubricant reservoir. The injectors reload, and the system is ready for the next lubrication cycle.

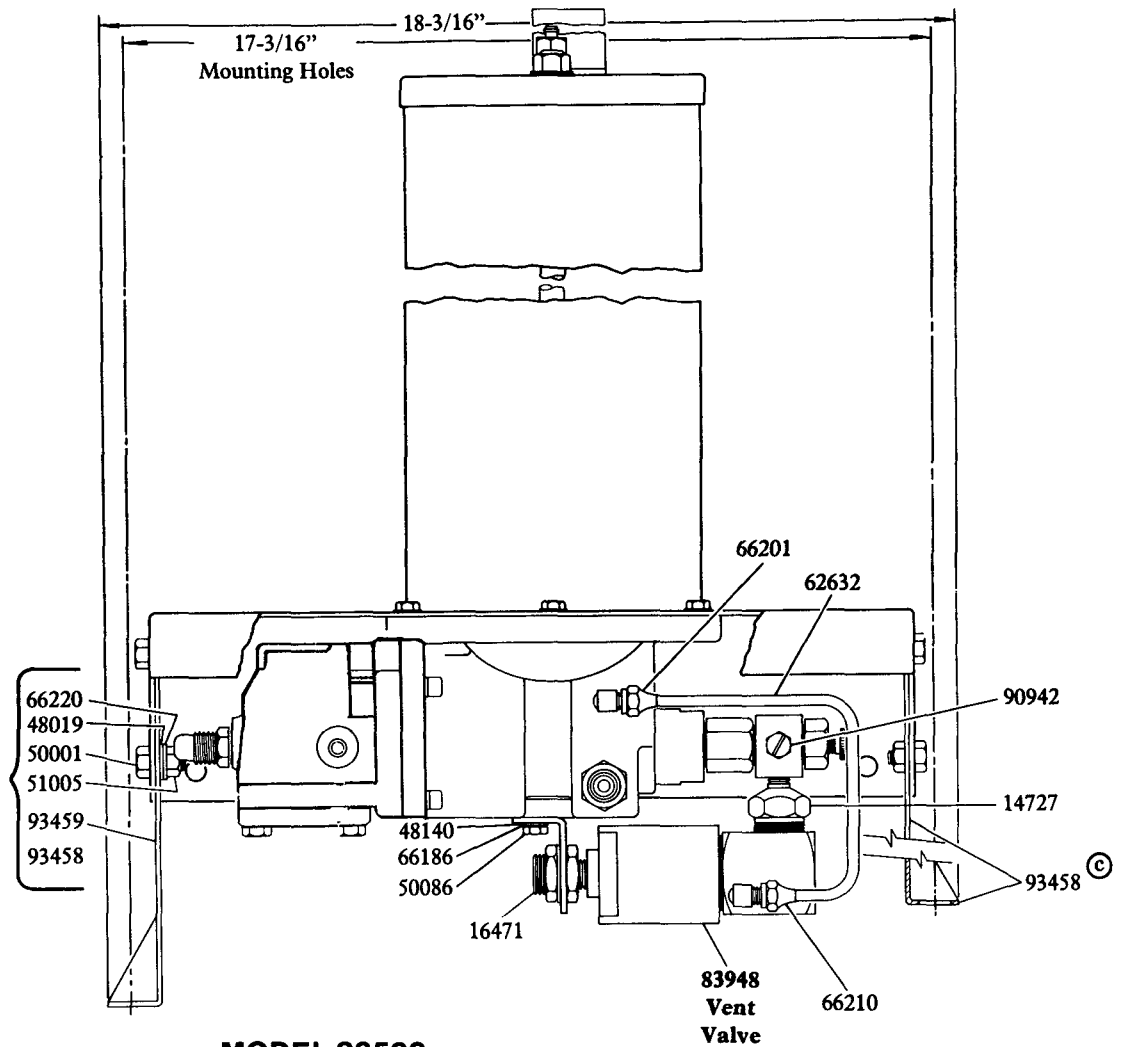
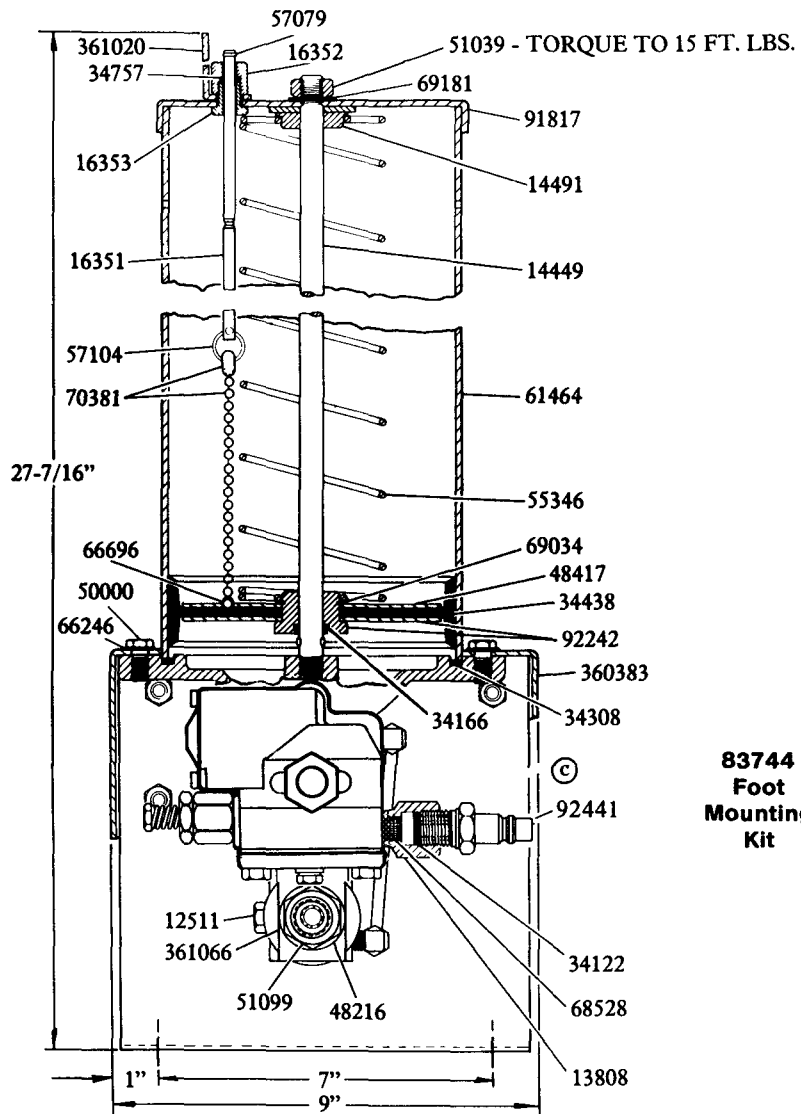

**MODEL 83599
 AIR OPERATED
 GREASE PUMP**

© Indicates change

IMPORTANT - Start fasteners by hand to avoid stripping threads when re-assembling.

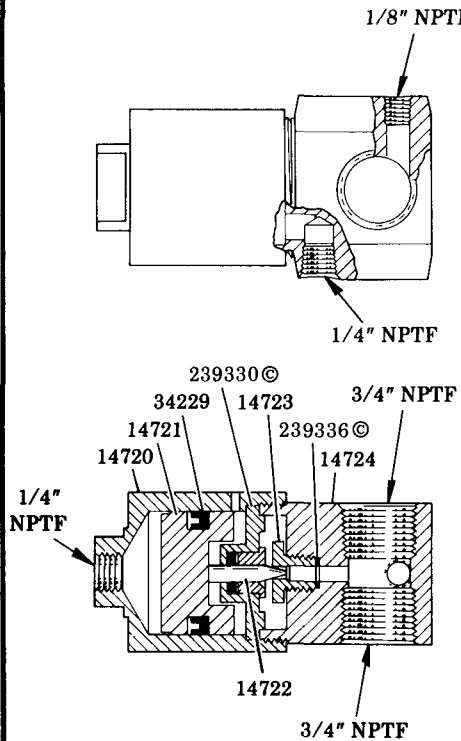

83948 VENT VALVE

WHAT TO DO IF:

Pump loses prime: Check lubricant supply.

A 10127 Vent Plug is provided at the pump outlet for expelling any air which may be pocketed in the lubricant. If pump operates continuously without discharging lubricant, it is an indication that the pump has lost its prime. Loosen vent plug one turn until trapped air is pumped out.

If pump still continues to operate without discharging lubricant, 10061 Pump Check Disc and 66002 Ball Check may be fouled. Remove and clean check and check seats.

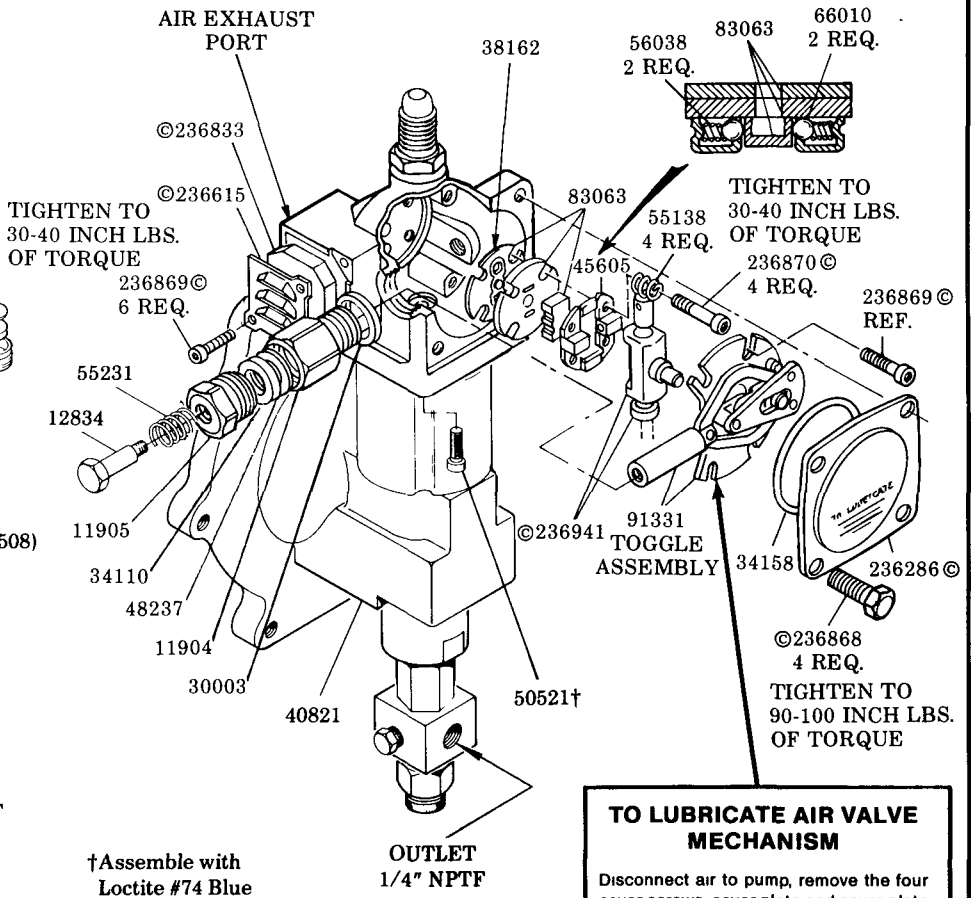
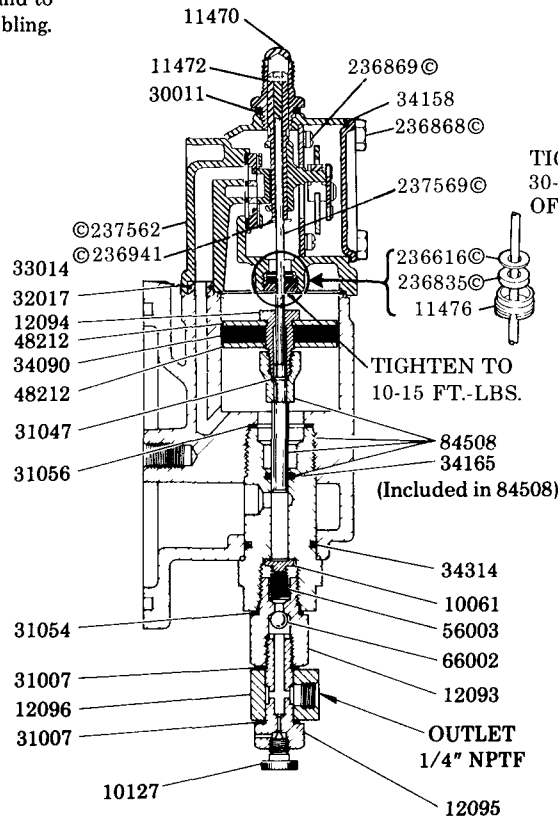

TO LUBRICATE AIR VALVE MECHANISM

Disconnect air to pump, remove the four cover screws, cover plate and cover plate gasket.

Remove and disassemble the air valve casting from the pump.

The air valve casting should be cleaned or flushed to remove any chips, or other foreign particles prior to re-assembly.

Before replacing the toggle assembly, pack cavity with grease.

Use NLGI No 1 (light grade) water repellent grease. Approximately 1½ ounces.

Replace cover gasket, cover, and screws. Tighten to avoid air leaks

Periodic inspection of parts at least once each year is advisable.

The 83948 Vent Valve may also be fouled. Foreign material may prevent the 14722 Needle from seating properly or 14723 Valve Seat may be worn or damaged. Clean or replace parts.

Failure of injectors to cycle can also be caused by a leak in the supply line. Examine lines and connections.

Pump fails to operate: Check air supply.

TO PRIME SYSTEM

SUPPLY LINES: After pump reservoir has been filled with recommended lubricant, remove all plugs in dead ends of the injector manifolds and supply lines. Turn vent plug in pump counter-clockwise one complete turn. Operate pump until lubricant flows freely from vent plug opening to expel air pockets trapped between the pump and the supply line connection. Tighten vent plug. Continue operating pump until lubricant flows from any plug opening. Close opening with plug. Repeat this procedure until all plug openings are closed and supply lines are primed.

FEEDER LINES: Fill each feed line with lubricant before connecting lines to outlet of injectors and bearings. This will prevent having to cycle each injector repeatedly to fill feed line between injector and bearing.

INJECTORS: Check each individual injector for proper operation.

VENT VALVE: The 83948 Vent Valve is operated by compressed air from the same source as that which operates the pump. When pump is in operation, air pressure keeps the vent valve closed and lubricant is directed through the outlet and to the injectors. When air to the pump is shut off, vent valve opens and supply line pressure vents back into the reservoir.

SAFETY UNLOADER: The 90942 Safety Unloader is provided at the pump outlet to prevent the build up of dangerously high lubricant pressure in the system. It is factory set to open at approximately 3,750 to 4,250 psi.

NOTE: Safety unloader requires no adjustment and should not be tampered with.

SERVICE PARTS

Part	Qty.	Description	Part	Qty.	Description
*10061	1	Pump check disc	50086	1	Bolt
10127	1	Plug	50521	4	Screw
11470	1	Cap	51005	10	Nut
*11472	1	Trip rod pin	51039	1	Nut
11476	1	Trip rod packing nut	51099	1	Nut
11904	1	Packing nut	55138	4	Spring
11905	1	Packing cap	*55231	1	Spring
12093	1	Check housing	55346	1	Follower spring
12094	1	Air piston bolt	*56003	1	Spring
12095	1	Outlet body	*56038	2	Spring
12096	1	Outlet block	57079	1	Ring
12511	2	Pipe plug	57104	1	Ring
12834	1	Spring retainer	61464	1	Reservoir
13808	1	Adapter	62632	1	Steel tubing
14449	1	Tie rod	*66002	1	Steel ball
14491	1	Retainer washer	*66010	2	Steel ball
14720	1	Air cylinder	66186	1	Lockwasher
14721	1	Piston	66201	1	Tube connector
*14722	1	Needle	66210	1	Tube connector
*14723	1	Valve seat	66220	10	Lockwasher
14727	1	Reducer nipple	66246	6	Lockwasher
16351	1	Indicator rod	66696	1	Sleeve
16352	1	Indicator nut	68528	1	Strainer
16353	1	Indicator plug	69034	1	Snap ring
16471	1	Support adapter	69181	1	Lockwasher
*30003	1	Gasket	70381	1	Bead chain
*30011	1	Gasket	*83063	1	Valve slide seat & gasket
*31007	2	Gasket	83744	1	Foot mounting kit
*31047	2	Gasket	83948	1	Vent valve assembly
*31054	1	Gasket	84508	1	Bushing, plunger & o-ring
*31056	1	Gasket	*90770	1	Trip rod
*32017	2	Gasket	*90942	1	Safety unloader
*33014	1	Gasket	*91331	1	Toggle plate
*34090	1	Packing	91817	1	Reservoir cap
*34110	1	Packing	92242	1	Bushing & washer ass'y.
*34122	1	Check disc packing	92441	1	Filler fitting
*34158	1	Gasket	93458	1	Bracket ass'y. (right)
*34165	1	O-ring	93459	1	Bracket ass'y. (left)
*34166	1	O-ring	236286	1	Cover
*34229	1	Packing	236615	1	Muffler cover
*34308	1	Gasket	*236616	1	Gasket
*34314	1	O-ring	236833	1	Muffler
34438	1	Follower	*236835	1	Packing
*34757	1	O-ring	236868	4	Screw
38162	1	Valve Gasket	*236869	6	Screw
40821	1	Base casting	236870	4	Valve seat bolt
45605	1	Valve guide plate	236941	1	Trip shoe assembly
48019	10	Washer	237562	1	Air valve casting
48140	1	Washer	*237569	1	Trip rod
48212	2	Washer	239330	1	Packing assembly
48216	1	Washer	239336	1	Valve body
48237	1	Washer	360383	1	Base
48417	1	Follower washer	361020	1	Indicator bracket
50000	6	Screw	361066	1	Bracket
50001	10	Bolt			

* Recommended Service Parts Inventory