

**SPECIFICATIONS**

**FOR OFF-HIGHWAY MINING TRUCKS**

Ratio	Lubricant Output (cu. in.)		Reservoir Capacity	Air Inlet	Lube Outlet	Lubricant Operating Pressure (PSI)			
	Per Cycle	Per Min @ 100 PSI				Type of System	Minimum	Maximum	Recommend
40:1	*.11	12	12 lbs.	1/4" NPTF	3/4" NPTF	SL-1 SL-11	1850	3500	2500
						SL-32 SL-33	1200	3500	1500

\* Based on lubricants that are free of entrapped air. Lubricants that are specifically aerated will reduce the output of the pump.

**WARNING**  
**DO NOT OPERATE THIS UNIT WITH COMBUSTIBLE GAS.**

**TYPICAL INSTALLATION**

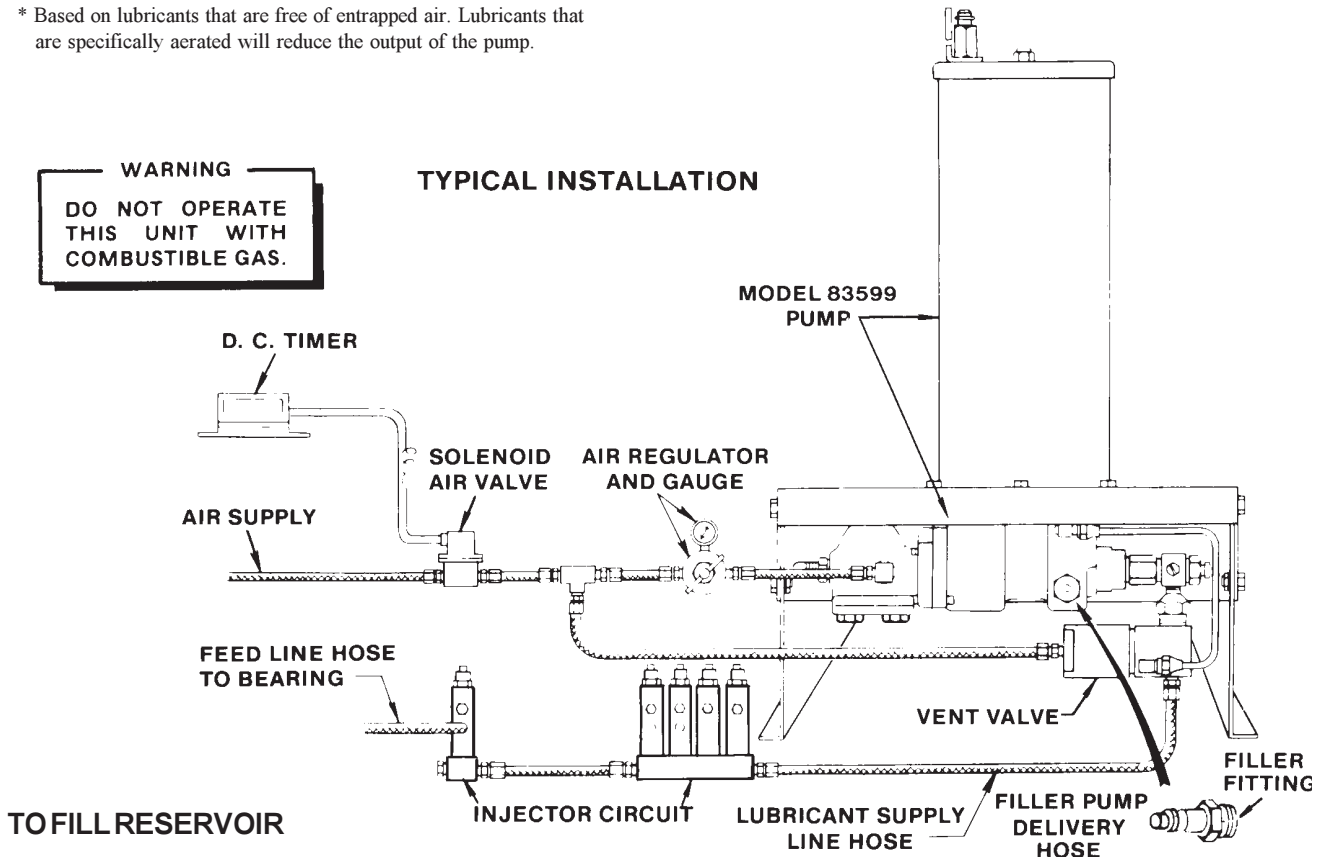

Use a manual filler pump to fill reservoir through the filler fitting in the pump body. Attach coupler on delivery hose to filler fitting. Stroke pump handle until lubricant weepage is noted at air vent hole in the reservoir (lower portion of follower must rise beyond air vent hole to expel entrapped air from lubricant).

**NOTE:** When filling the reservoir, caution should be used as extreme pressure can cause damage to reservoir and follower assembly.

**OPERATION**

The operation of the 83599 Pump is fully automatic, controlled by a 12 or 24 volt D.C. electric timer and electric operated solenoid air valve. As the truck operates, the timer periodically turns on a switch which energizes the solenoid air valve. The solenoid air valve opens, and admits regulated air to the Centro-matic Pump, closing the vent valve. The pump begins to operate, delivering lubricant through the supply lines to each lubricant injector.

As the pump builds up pressure, a measured amount of lubricant is dispensed to the bearings by each injector. After all injectors have cycled, lubricant pressure rises rapidly to 2400 psi with air regulated to 60 psi, and the pump stalls against pressure.

The timer switch contact is broken, and the solenoid air valve is de-energized, shutting off the air supply; air then exhausts from the pump and vent valve assembly. As air is relieved, the vent valve opens and lubricant pressure in the system vents back through the supply line to the lubricant reservoir. The injectors reload, and the system is ready for the next lubrication cycle.

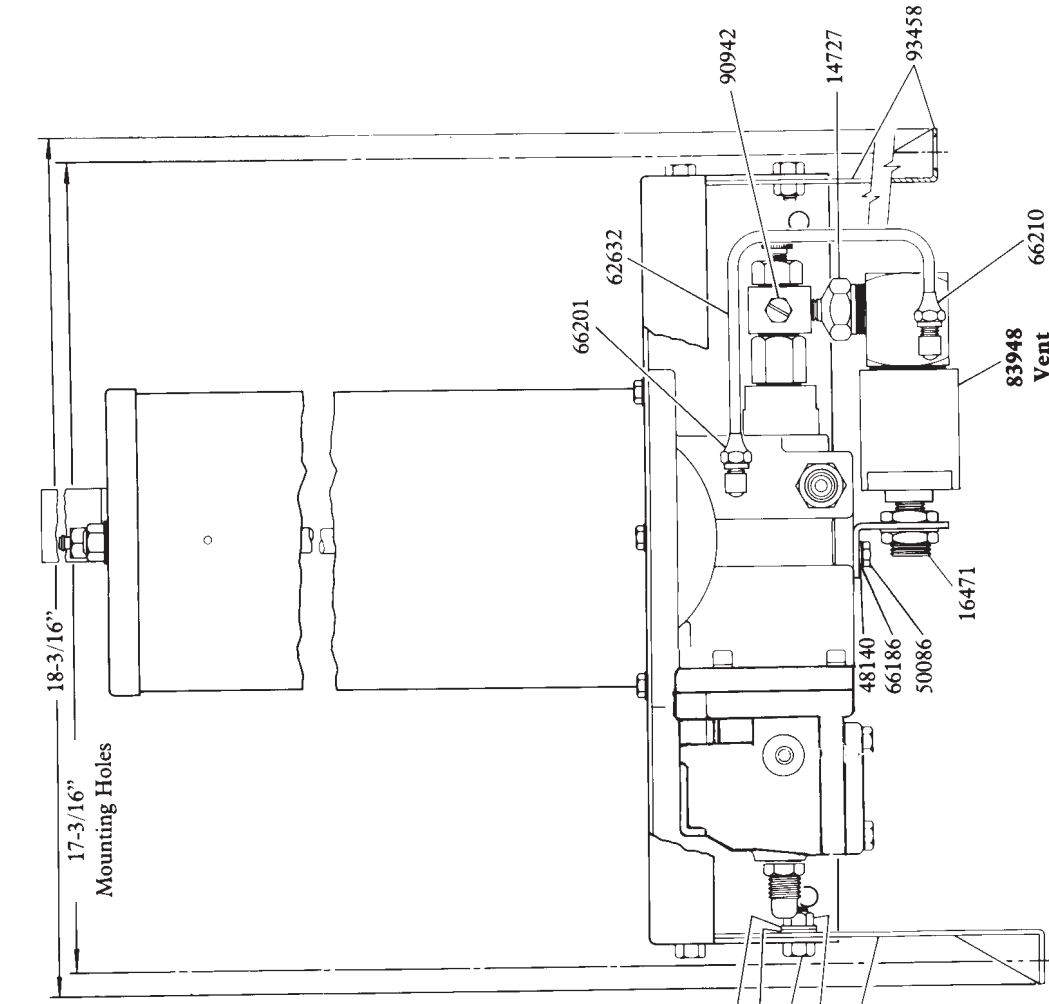

**MODEL 83599  
AIR OPERATED  
GREASE PUMP**

Restrictor, P/N 16577  
(not furnished with pump)  
may be added at airmotor  
inlet to reduce pump noise.  
Pump speed and output  
per minute will be  
reduced accordingly.

**83744  
Foot  
Mounting  
Kit**

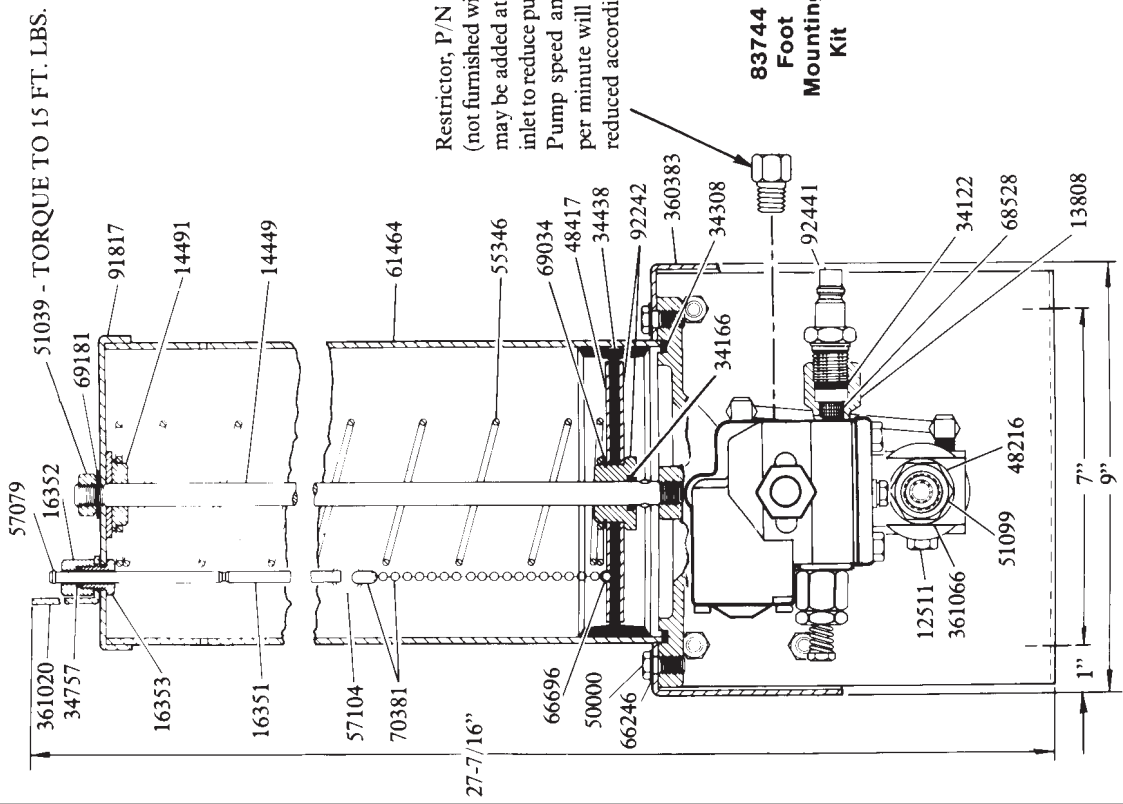

© Indicates Change

**IMPORTANT** - Start fasteners by hand to avoid stripping threads when re-assembling.

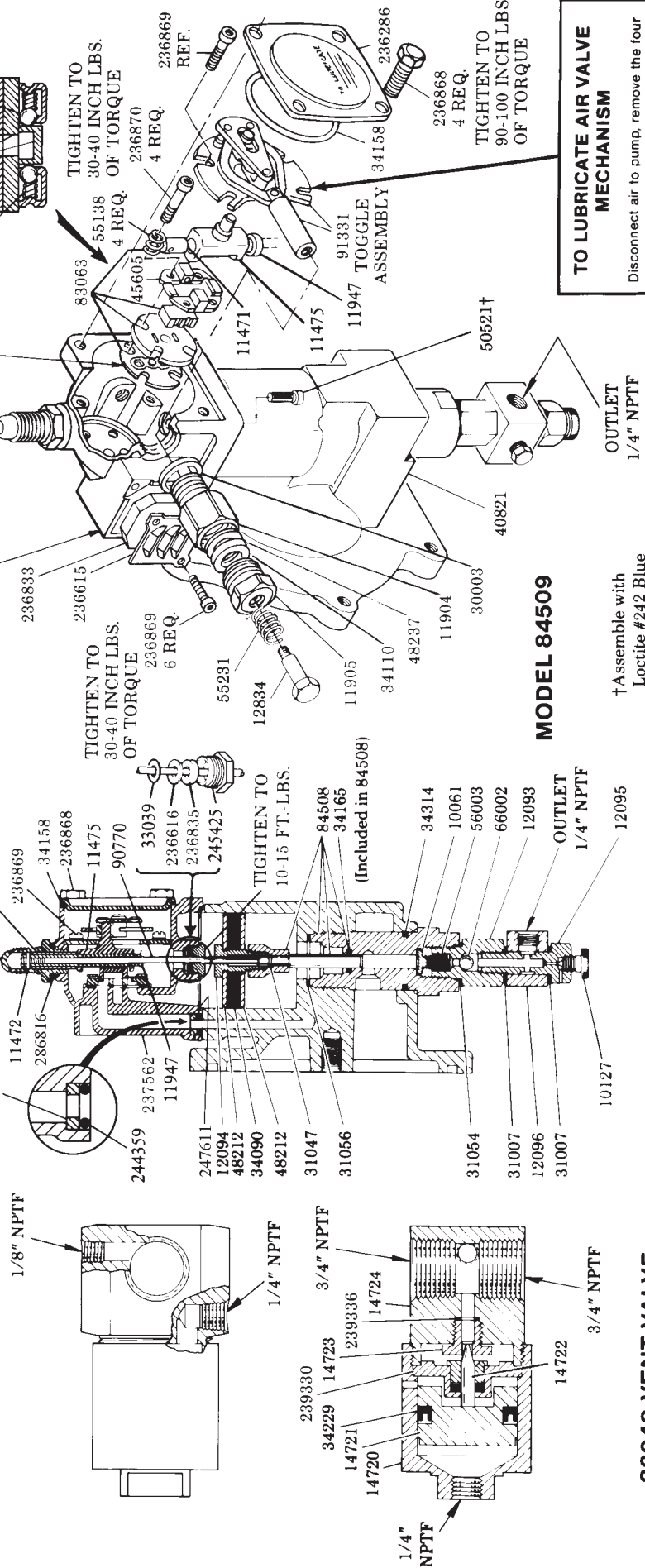

**83948 VENT VALVE**

**WHAT TO DO IF:**

Pump loses prime: Check lubricant supply.

A 10127 Vent Plug is provided at the pump outlet for expelling any air which may be pocketed in the lubricant. If pump operates continuously without discharging lubricant, it is an indication that the pump has lost its prime. Loosen vent plug one turn until trapped air is pumped out.

If pump still continues to operate without discharging lubricant, 10061 Pump Check Disc and 66002 Ball Check may be fouled. Remove and clean check and check seats.

**TO LUBRICATE AIR VALVE MECHANISM**

Disconnect air to pump, remove the four cover screws, cover plate and cover plate gasket.

Remove and disassemble the air valve casting from the pump.

The air valve casting should be cleaned or flushed to remove any chips, or other foreign particles prior to re-assembly.

Before replacing the toggle assembly, pack cavity with grease.

Use NLGINo. 1 (light grade) water repellent grease. Approximately 1½ ounces.

Replace cover gasket, cover, and screws. Tighten to avoid air leaks.

Periodic inspection of parts at least once each year is advisable.

**MODEL 84509**

† Assemble with Loctite #242 Blue

The 83948 Vent Valve may also be fouled. Foreign material may prevent the 14722 Needle from seating properly or 14723 Valve Seat may be worn or damaged. Clean or replace parts.

Failure of injectors to cycle can also be caused by a leak in the supply line. Examine lines and connections.

Pump fails to operate: Check air supply.

OUTLET  
1/4" NPTF

OUTLET  
1/4" NPTF

OUTLET  
1/4" NPTF

OUTLET  
1/4" NPTF

OUTLET  
1/4" NPTF

OUTLET  
1/4" NPTF

## TO PRIME SYSTEM

**SUPPLY LINES:** After pump reservoir has been filled with recommended lubricant, remove all plugs in dead ends of the injector manifolds and supply lines. Turn vent plug in pump counter-clockwise one complete turn. Operate pump until lubricant flows freely from vent plug opening to expel air pockets trapped between the pump and the supply line connection. Tighten vent plug. Continue operating pump until lubricant flows from any plug opening. Close opening with plug. Repeat this procedure until all plug openings are closed and supply lines are primed.

**FEEDER LINES:** Fill each feed line with lubricant before connecting lines to outlet of injectors and bearings. This will prevent having to cycle each injector repeatedly to fill feed line between injector and bearing.

**INJECTORS:** Check each individual injector for proper operation.

**VENT VALVE:** The 83948 Vent Valve is operated by compressed air from the same source as that which operates the pump. When pump is in operation, air pressure keeps the vent valve closed and lubricant is directed through the outlet and to the injectors. When air to the pump is shut off, vent valve opens and the supply line pressure vents back into the reservoir.

**SAFETY UNLOADER:** The 90942 Safety Unloader is provided at the pump outlet to prevent the build up of dangerously high lubricant pressure in the system. It is factory set to open at approximately 3,750 to 4,250 psi.

**NOTE:** Safety unloader requires no adjustment and should not be tampered with.

## SERVICE PARTS

Part	Qty.	Description	Part	Qty.	Description	Part	Qty.	Description
#*10061	1	Pump check disc	*34166	1	O-ring (Nitrile)	66696	1	Sleeve
10127	1	Plug	*34229	1	Packing (Nitrile)	68528	1	Srainer
11470	1	Cap	*34308	1	Gasket (Nitrile)	69034	1	Snap ring
#*11471	1	Trip rod collar	#*34314	1	O-ring (Nitrile)	69181	1	Lockwasher
#*11472	1	Trip rod pin	34438	1	Follower (Nitrile)	70381	1	Bead chain
#*11475	1	Trip shoe	*34757	1	O-ring (Nitrile)	#*83063	1	Valve slide seat & gasket
11904	1	Packing nut	#38162	1	Valve gasket (Nitrile)	83744	1	Foot mounting kit
11905	1	Packing cap	40821	1	Base casting	83948	1	Vent valve assembly
#*11947	1	Trip sleeve	#45605	1	Valve guide plate	84508	1	Bushing, plunger & o-ring
12093	1	Check housing	48019	10	Washer	#*90770	1	Trip rod
12094	1	Air piston bolt	48140	1	Washer	*90942	1	Safety unloader
12095	1	Outlet body	48212	2	Washer	#*91331	1	Toggle plate
12096	1	Outlet block	48216	1	Washer	*91817	1	Reservoir cap
12511	2	Pipe plug	48237	1	Washer	92242	1	Bushing & washer ass'y.
12834	1	Spring retainer	48417	1	Follower washer	92441	1	Filler fitting
13808	1	Adapter	50000	6	Screw	93458	1	Bracket ass'y (right)
14449	1	Tie rod	50001	10	Bolt	93459	1	Bracket ass'y (left)
14491	1	Retainer washer	50086	1	Bolt	236286	1	Cover
14720	1	Air cylinder	50521	4	Screw	236615	1	Muffler cover
*14721	1	Piston	51005	10	Nut	#*236616	1	Gasket
*14722	1	Needle	51039	1	Nut	236833	1	Muffler
*14723	1	Valve seat	51099	1	Nut	#*236835	1	Packing
14727	1	Reducer nipple	55138	4	Spring	236868	4	Screw
16351	1	Indicator rod	*55231	1	Spring	*236869	6	Screw
16352	1	Indicator nut	55346	1	Follower spring	236870	4	Valve seat bolt
16353	1	Indicator plug	*56003	1	Spring	237562	1	Air valve casting
16471	1	Support adapter	*56038	2	Spring	239330	1	Packing assembly
*30003	1	Gasket	57079	1	Ring	239336	1	Valve body
#*31007	2	Gasket	57104	1	Ring	#*244313	1	Seat
*31047	2	Gasket	61464	1	Reservoir	#*244359	1	O-ring (Nitrile)
*31054	1	Gasket	62632	1	Steel tubing	#*245425	1	Trip rod packing nut
*31056	1	Gasket	*66002	1	Steel ball	246816	1	Gasket
#*33039	1	Gasket	*66010	2	Steel ball	#*247611	1	Gasket (Nitrile coated fiber)
*34090	1	Packing (Nitrile)	66186	1	Lockwasher	360383	1	Base
*34110	1	Packing (Nitrile)	66201	1	Tube connector	361020	1	Indicator bracket
*34122	1	Check disc packing	66210	1	Tube connector	361066	1	Bracket
*34158	1	Gasket	66220	10	Lockwasher			
*34165	1	O-ring (Nitrile)	66246	6	Lockwasher			

\*Recommended Service Parts Inventory. #Included in 246415 Repair Kit.

### RETAIN THIS INFORMATION FOR FUTURE REFERENCE

When ordering replacement parts, list: Part Number, Description, Model Number and Series Letter.  
LINCOLN provides a Distributor Network that stocks equipment and replacement parts.