

**HEAT RESISTANT
FOR DISPENSING OIL ONLY**

MANIFOLD CHART

SPECIFICATIONS

OUTPUT: Adjustable from .001 cu. in. to .003 cu. in.
OPERATING PRESSURE: 750 psi to 1000 psi
RECOMMENDED OPERATING PRESSURE: ... 850 psi
RECHARGE PRESSURE: 150 psi
WORKING TEMPERATURE: 350° F Max.

† Black finish indicates Heat Resistant Injector

© Indicates Change

DESCRIPTION	MODEL	MANIFOLD	DIMENSIONS	
			A	B
1 Unit	84428-1	91863-1	1-1/8"	1-5/8"
2 "	84428-2	91864-1	1-7/8"	2-3/8"
3 "	84428-3	91865-1	2-5/8"	3-1/8"
4 "	84428-4	91866-1	3-3/8"	3-7/8"
5 "	84428-5	14361	4-1/8"	4-5/8"
6 "	84428-6	91976-1	4-7/8"	5-3/8"
8 "	84428-8	14291	6-3/8"	6-7/8"
10 "	84428-10	14312	7-7/8"	8-3/8"
15 "	84428-15	14253	11-5/8"	12-1/8"
18 "	84428-18	14332	13-7/8"	14-3/8"

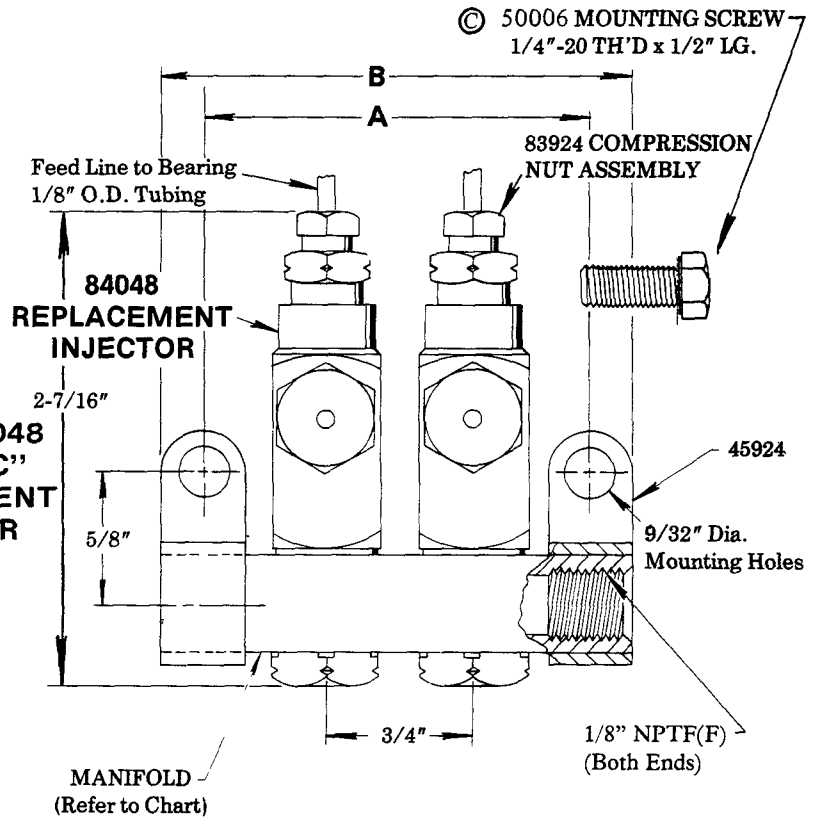
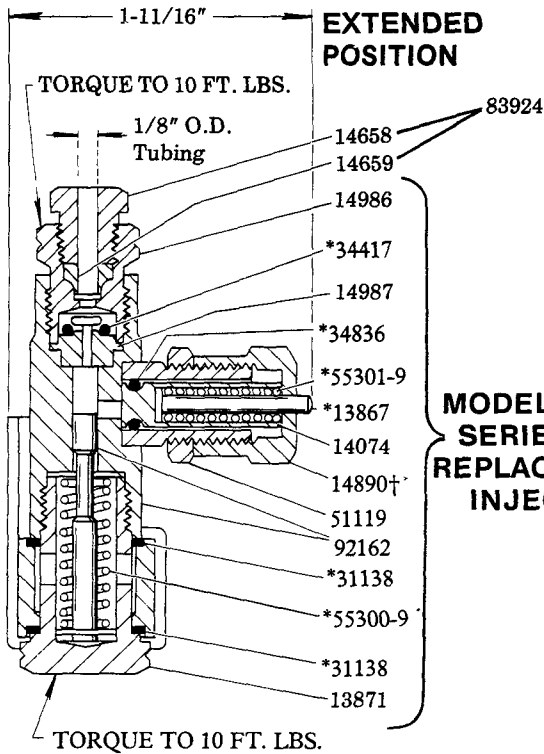

SERVICE PARTS

PART	QUAN.	DESCRIPTION	PART	QUAN.	DESCRIPTION
*13867	1	Injector indicator	*34417	1	O-ring
13871	1	Adapter	*34836	1	O-ring
14074	1	Packing retainer	45924	2	Manifold mounting clip
14658	1	Compression nut	50006	2	Mounting screw
14659	1	Ferrule	51119	1	Locknut
14890	1	Injector cap	*55300-9	1	Spring
14986	1	Outlet body	*55301-9	1	Spring
14987	1	Outlet seat	83924	1	Compression nut ass'y.
*31138	2	Gasket	92162	1	Body & plunger ass'y.

*Included in 236467 Repair kit.

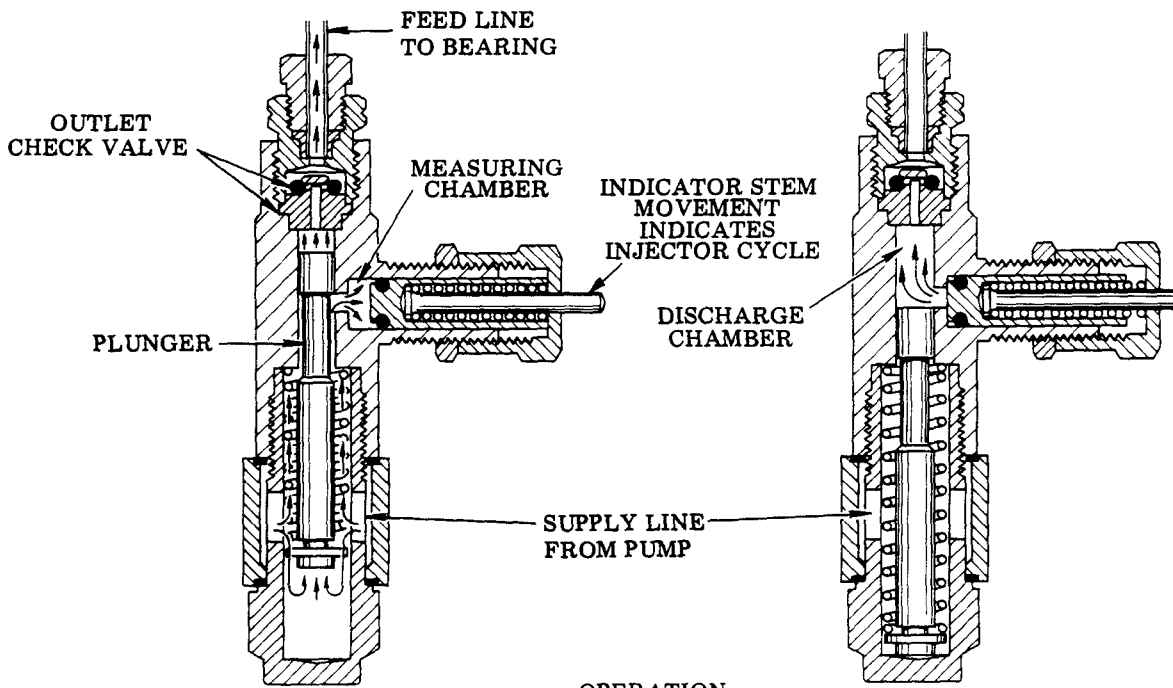

SUPPLY LINE UNDER PRESSURE

(Normal operating pressure 850 psi)

Lubricant pressure moves plunger to force lubricant in the discharge chamber through the outlet check valve to the feed line.

Lubricant from supply line charges the measuring chamber.

SUPPLY LINE VENTED

(Vent pressure 150 psi maximum)

Plunger returns to normal position after supply line is vented, connecting measuring chamber to the discharge chamber. Flow from feed line is blocked by the outlet check valve.

Lubricant is automatically transferred from measuring chamber to discharge chamber.

INJECTOR ADJUSTMENT

Injector output is controlled by the position of the indicator cap which limits the travel of the packing retainer.

With the indicator cap hand tightened against its stop, the lubricant output is decreased to a minimum.

Retracting the indicator cap two full turns permits a maximum of .003 cu. in. to be dispensed.

Retracting the indicator cap beyond two full turns will not increase the lubricant output.

When the injector has been adjusted for the proper lubricant output, the lock nut is tightened against the face of the indicator cap.

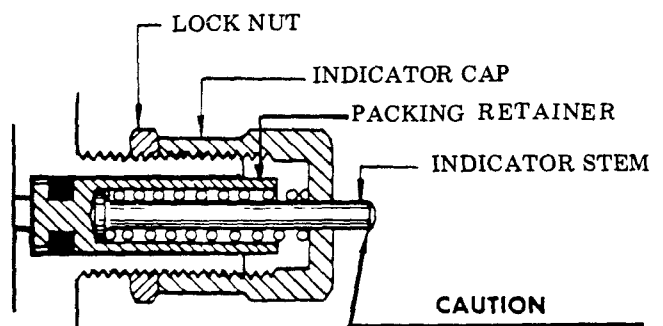

CAUTION

INDICATOR CAP MUST NOT EXTEND BEYOND RETRACTED POSITION OF INDICATOR STEM

RETAIN THIS INFORMATION FOR FUTURE REFERENCE

When ordering replacement parts, list: Part Number, Description, Model Number, and Series Letter.

LINCOLN provides a Distributor Network that stocks equipment and replacement parts.

A list of Authorized Service Departments will be furnished upon request.