

**HEAT RESISTANT  
FOR DISPENSING OIL ONLY  
SPECIFICATIONS**

OUTPUT:.....Adjustable from .001 cu. in. to .003 cu. in.  
OPERATING PRESSURE:.....750 psi to 1000 psi  
RECOMMENDED OPERATING PRESSURE:.....850 psi  
RECHARGE PRESSURE:.....150 psi  
WORKING TEMPERATURE:.....350°F Max.

† Black finish indicates Heat Resistant Injector

**MANIFOLD CHART**

Model	Description	Dimensions		Manifold
		A	B	
84428-1	1 Unit	1-1/8"	1-5/8"	91863-1
84428-2	2 Unit	1-7/8"	2-3/8"	91864-1
84428-3	3 Unit	2-5/8"	3-1/8"	91865-1
84428-4	4 Unit	3-3/8"	3-7/8"	91866-1
84428-5	5 Unit	4-1/8"	4-5/8"	14361
84428-6	6 Unit	4-7/8"	5-3/8"	91976-1
84428-10	10 Unit	7-7/8"	8-3/8"	14312
84428-15	15 Unit	11-5/8"	12-1/8"	14253
84428-18	18 Unit	13-7/8"	14-3/8"	14332

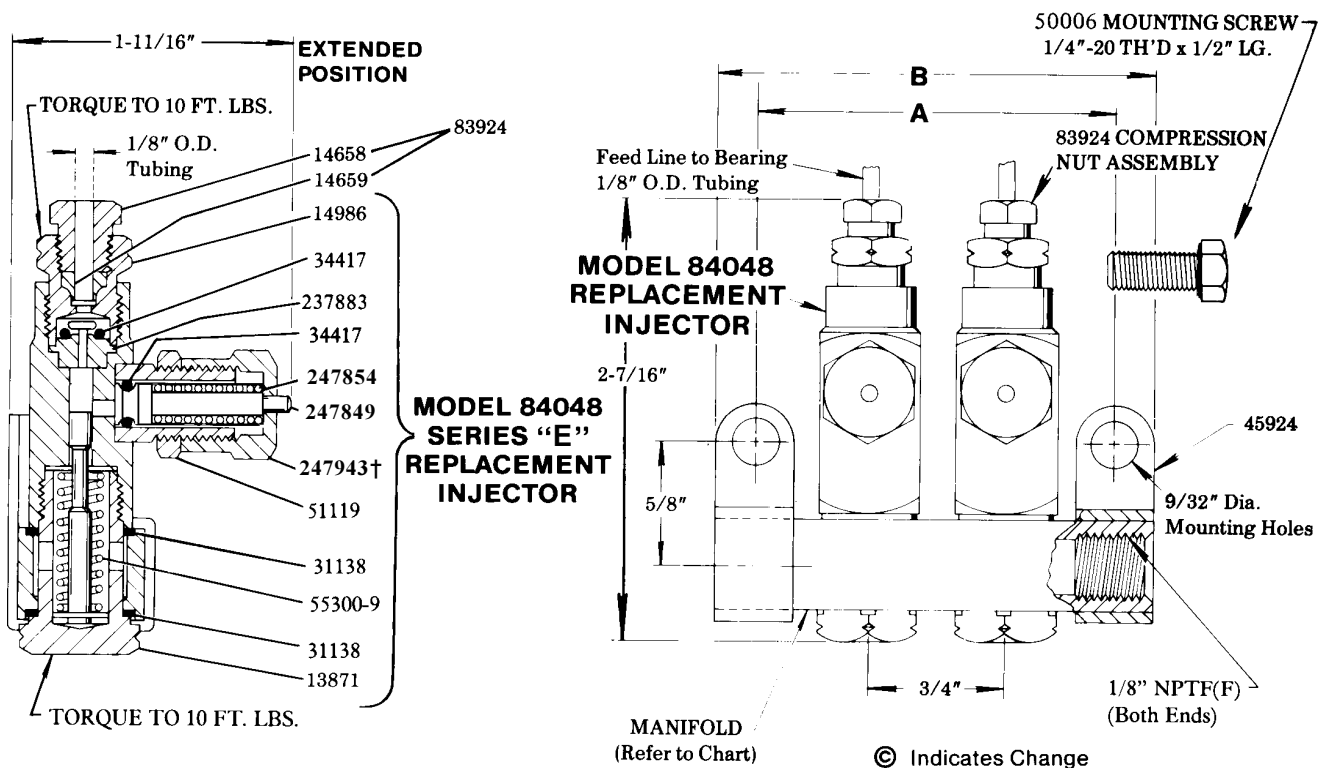

**SERVICE PARTS**

Model	Qty.	Description	Model	Qty.	Description
13871	1	Adapter	51119	1	Locknut
14658	1	Compression nut	+*55300-9	1	Spring
14659	1	Ferrule	83924	1	Compression nut ass'y.
14986	1	Outlet body	+*237883	1	Outlet seat
+*31138	2	Gasket	+ 247849	1	Piston
+*34417	2	O-ring (Viton)	+*247854	1	Spring
45924	2	Manifold mounting clip	+ 247943	1	Injector Cap
50006	2	Mounting screw			

**NOTE:** Injectors from previous series can be improved with stenciled cap and single piece piston by use of 247956 upgrade kit.

\*Included in 247961 Repair Kit +Included in 247956 Upgrade Kit

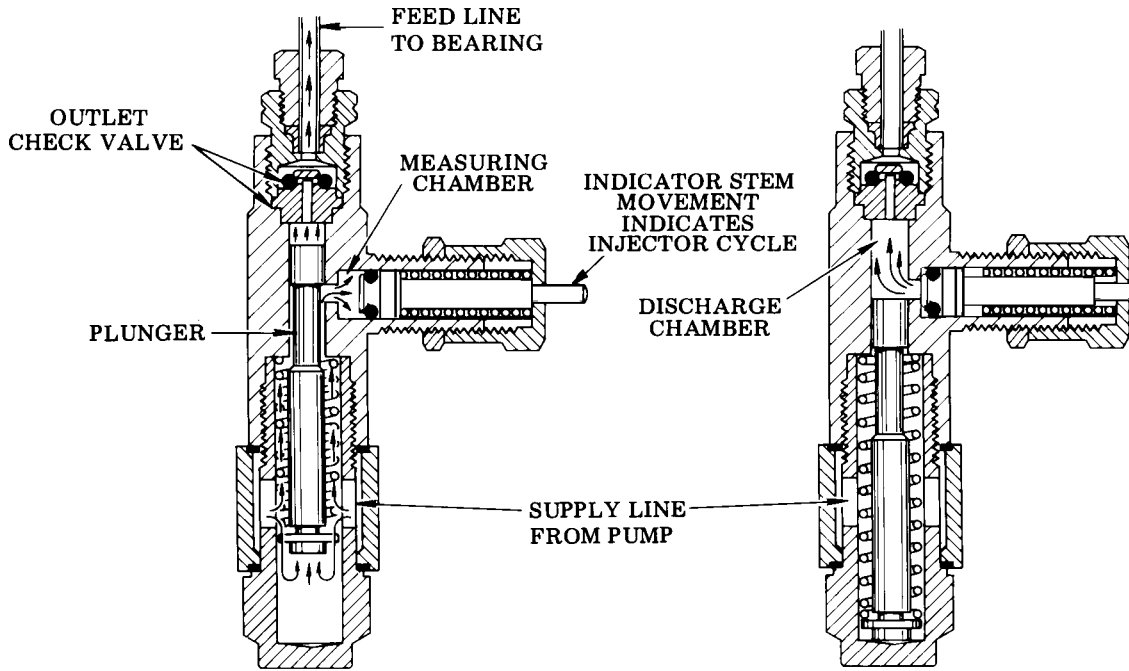

### OPERATION

#### SUPPLY LINE UNDER PRESSURE

(Normal operating pressure 850 psi)

Lubricant pressure moves plunger to force lubricant in the discharge chamber through the outlet check valve to the feed line.

Lubricant from supply line charges the measuring chamber.

#### SUPPLY LINE VENTED

(Vent pressure 150 psi maximum)

Plunger returns to normal position after supply line is vented, connecting measuring chamber to the discharge chamber. Flow from feed line is blocked by the outlet check valve.

Lubricant is automatically transferred from measuring chamber to discharge chamber.

### INJECTOR ADJUSTMENT

Injector output is controlled by the position of the indicator cap which limits the travel of the indicator piston.

With the indicator cap hand tightened against its stop, the lubricant output is decreased to a minimum.

Retracting the indicator cap two full turns permits a maximum of .003 cu. in. to be dispensed. Use the graduations on the cap as an aid in setting the indicator.

When the injector has been adjusted for the proper lubricant output, the lock nut is tightened against the face of the indicator cap.

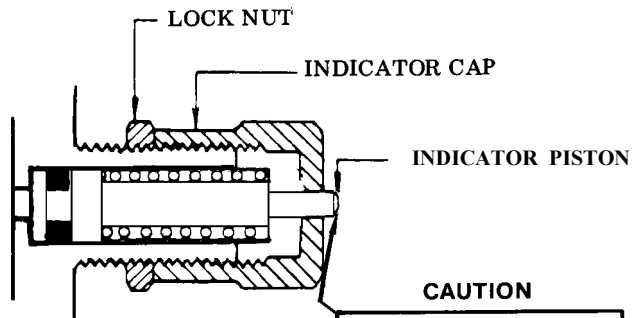

#### CAUTION

INDICATOR CAP MUST NOT EXTEND BEYOND RETRACTED POSITION OF INDICATOR STEM.

### RETAIN THIS INFORMATION FOR FUTURE REFERENCE

When ordering replacement parts, list: Part Number, Description, Model Number and Series Letter. LINCOLN provides a Distributor Network that stocks equipment and replacement parts.