

*new 1/2" for
2 1/2"*

SPECIFICATIONS:

OUTPUT..... Adjustable from .001 cu in to .008 cu in
 OPERATING PRESSURE:..... 750 psi to 1000 psi
 RECHARGE PRESSURE:..... 150 psi Max.
 WORKING TEMPERATURE:..... 350 F Max

**FOR DISPENSING OIL
HEAT RESISTANT**

†Black finish indicates Heat Resistant Injector

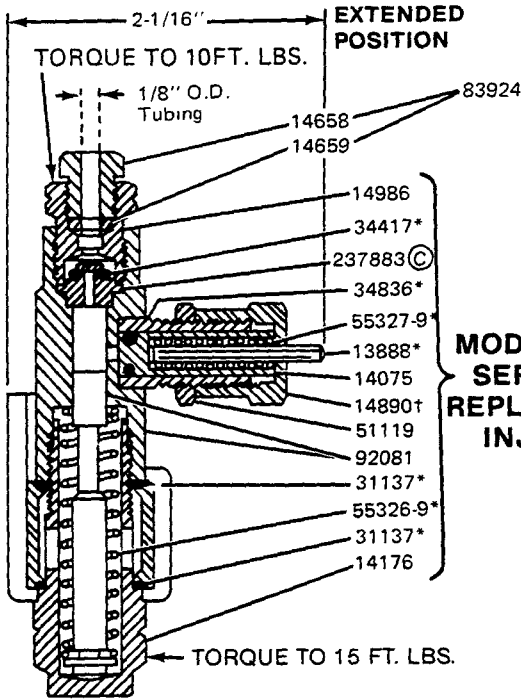

©Indicates Change

**MODEL 84110
SERIES "C"
REPLACEMENT
INJECTOR**

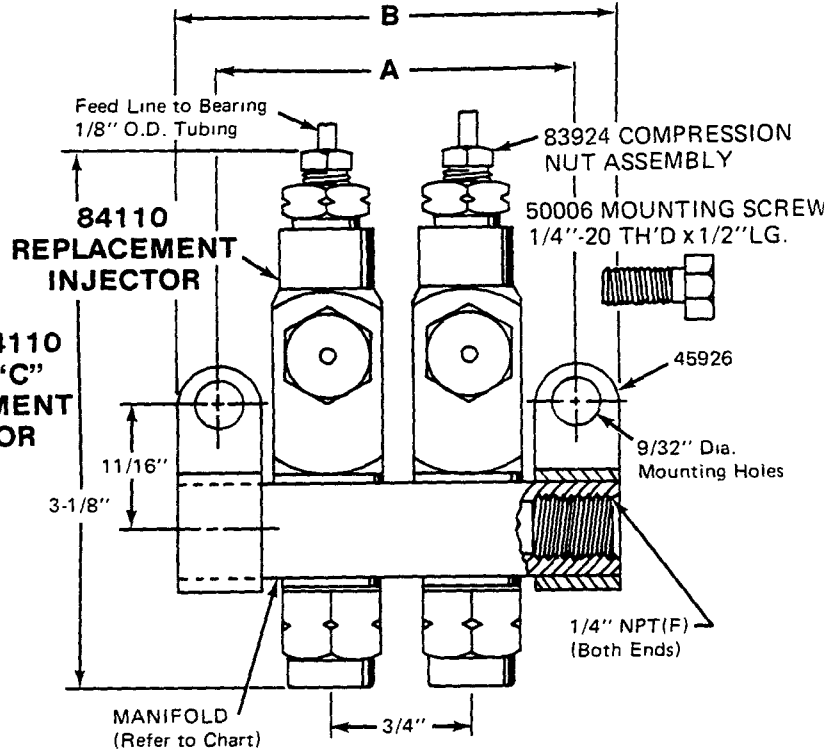

MANIFOLD CHART

Description	Model	Manifold	Dimensions	
			A	B
1 UNIT	84429-1	91883-1	1-1/4"	1-3/4"
2 "	84429-2	91884-1	2"	2-1/2"
3 "	84429-3	91885-1	2-3/4"	3-1/4"
4 "	84429-4	91886-1	3-1/2"	4"

SERVICE PARTS

Part	Qty.	Description	Part	Qty.	Description
*13888	1	Injector indicator	*34417	1	O-ring
14075	1	Packing retainer	*34836	1	Packing
14176	1	Adapter	45926	2	Manifold mounting clip
14658	1	Compression nut	50006	2	Mounting screw
14659	1	Ferrule	51119	1	Lock nut
14890	1	Injector cap	*55326-9	1	Spring
14986	1	Outlet body	*55327-9	1	SPRING
237883	1	Outlet seat	83924	1	Compression nut ass'y.
*31137	2	Gasket	92081	1	Body & plunger ass'y

*Included in 236461 Repair kit.

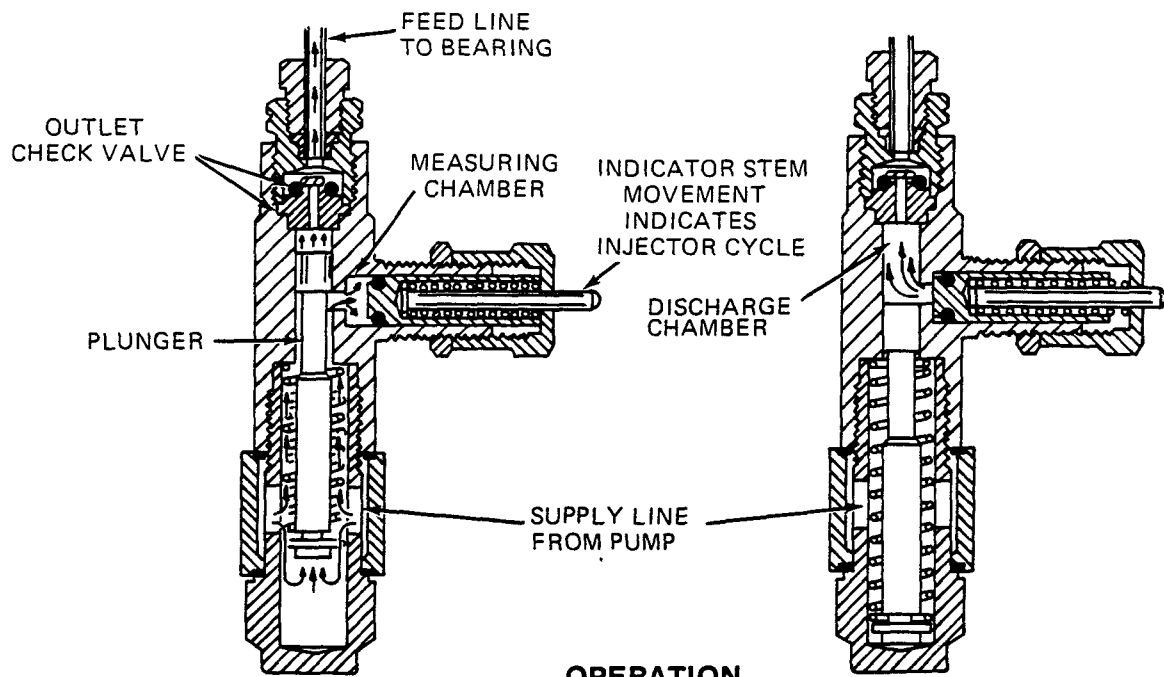

SUPPLY LINE UNDER PRESSURE

(Normal operating pressure 850 psi)

Lubricant pressure moves plunger to force lubricant in the discharge chamber through the outlet check valve to the feed line.

Lubricant from supply line charges the measuring chamber

SUPPLY LINE VENTED

(Vent pressure 150 psi maximum)

Plunger returns to normal position after supply line is vented, connecting measuring chamber to the discharge chamber. Flow from feed line is blocked by the outlet check valve.

Lubricant is automatically transferred from measuring chamber to discharge chamber.

INJECTOR ADJUSTMENT

Injector output is controlled by the position of the indicator cap which limits the travel of packing retainer.

With the indicator cap hand tightened against its stop, the lubricant output is decreased to a minimum.

Retracting the indicator cap five full turns permits a maximum of .008 cu. in. to be dispensed.

Retracting the indicator cap beyond five full turns will not increase the lubricant output.

When the injector has been adjusted for the proper lubricant output, the lock nut is tightened against the face of the indicator cap

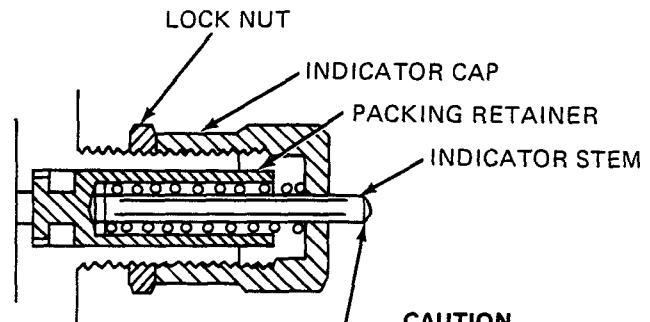

CAUTION

INDICATOR CAP MUST NOT EXTEND BEYOND RETRACTED POSITION OF INDICATOR STEM.

RETAIN THIS INFORMATION FOR FUTURE REFERENCE

When ordering replacement parts, list: Part Number, Description, Model Number, and Series Letter.

LINCOLN provides a Distributor Network that stocks equipment and replacement parts.