

DESCRIPTION—MODEL 1833

Model 1833 is an electric-operated pump (designed for installation on mobile machinery where power is received from vehicle storage battery) consisting of an electric motor, a reciprocating-type pumping mechanism, lubricant reservoir and a control unit (timing mechanism). With full reservoir, total weight: 80 lbs.

MOTOR

A 1/4 H.P., 24 VDC, 10 AMP, 1800 RPM electric motor supplies power to the pump. A thermal overload protection to guard against extreme heat build up is incorporated.

PUMPING MECHANISM

An average of 10 oz. per minute (18 cu. in.) with pumping pressures as high as 2900 psi can be attained. Pump operation is factory pre-set for 2500 psi. A high pressure safety unloader (set to unload at 3750 to 4250 psi) is provided for protection against excessive pressure. The outlet check can be easily removed for inspection and service.

IMPORTANT: *It is recommended that the Gear Box be checked periodically to maintain the proper level of S.A.E. 80 Gear Lubricant.*

RESERVOIR

The lubricant reservoir has a capacity of 12 lbs. Lubricant level is denoted by the indicator rod & gauge. The reservoir assembly is gasketed and covered to prevent the entry of possible contaminants. Filling is done through the fill nipple which also strains the grease before entering the reservoir.

CONTROL UNIT

Refer to back page for wiring instructions and information for Control Unit.

MANUAL LUBE

A pushbutton switch has been provided with this unit permitting both ease of filling large supply lines after installation and manual operation of system anytime between clocked lubrication cycles. If pushbutton switch is used, it should be wired to the terminals on the front of the control unit marked "MANUAL LUBE." By depressing the switch and holding it "ON," the motor will run independent of the timer and continue to run until the desired system pressure is reached. At this point, the pressure switch contacts will open, stopping the motor. The pushbutton switch **MUST** be released at this time or, as the system begins to vent pressure, the motor will restart.

CONTROL UNIT

The control consists of a pressure switch, a solenoid switch, a time delay relay and a timer.

The pressure switch has been factory set for actuating at 2500 psi system pressure. Should a different pressure be desired, the switch hold down screws should be loosened only enough for the switch to be moved along the slide bracket and re-positioned (move switch closer to the actuating pin for lower pressures, and farther away for higher pressures). Disengaging the hold down screw from the threaded plate located beneath the slide bracket will require removal of the switch and bracket from the control unit and assembling back together.

The solenoid switch is a four terminal, single pole, normally open contactor that serves to deliver or interrupt power from the battery to the motor. The contact rating is 50 AMPS continuous at 24 VDC. The solenoid is also equipped with an isolated continuous duty coil for trouble-free operation.

The time delay relay limits pumping time to 60 secs. max. and also serves as an alarm relay if the desired system pressure is not achieved within this time, signalling an external alarm (Supplied by customer).

Refer to "ALARM" connections, FIG. B.

The timer (Power requirements: 5 WATTS max.) has a selector switch which provides for time cycle adjustments of 2.5, 5, 10, 20, 40, and 80 minutes between lube cycles. Adjustments are made by removing the control unit cover and turning knob to the desired time. Timer is suitable for operation in areas where ambient temperature is more than -0°F (-18°C) and less than 130°F (55°C).

NOTE:

Time indicated does not include pumping time.

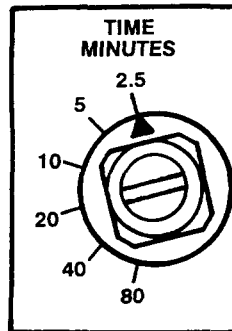

Relay contacts shown in "ALARM" position

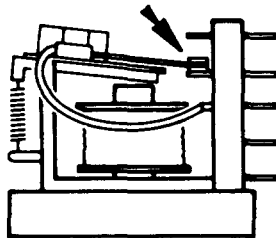

If the customer chooses not to connect an external alarm device to the unit, visual inspection of the time delay relay will denote "ALARM" condition. Contacts transferring to the low position energize the alarm circuit.

NOTE: Visual inspection of relay contacts **MUST** be done before ignition switch is turned "OFF" otherwise contacts return to the normal position.

CONTROL UNIT- Side terminal connections

(Refer to Wiring Diagram and FIG. A)

IMPORTANT: This unit **MUST** be wired maintaining proper polarity to avoid internal damage to circuitry.

Connect positive (+) from battery through a fuse (F) to enclosure terminal (BAT.+); the (BAT.-) terminal on the enclosure connects to vehicle ground. The (IGN.) terminal of the enclosure **MUST** be connected to one side of the ignition switch. The other side of the ignition switch goes to the (+) of battery.

NOTE: Lubrication cycles will occur at set intervals only when ignition switch is turned "ON." No pre-lube is initiated when the ignition switch is turned "ON."

FIG. A

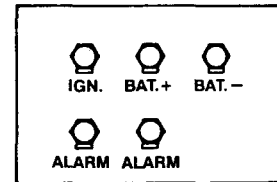

TYPICAL "ALARM" CONNECTIONS FOR NEGATIVE GROUND VEHICLES.

FIG. B

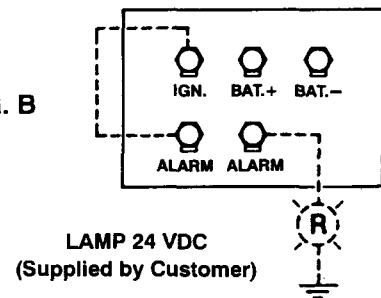

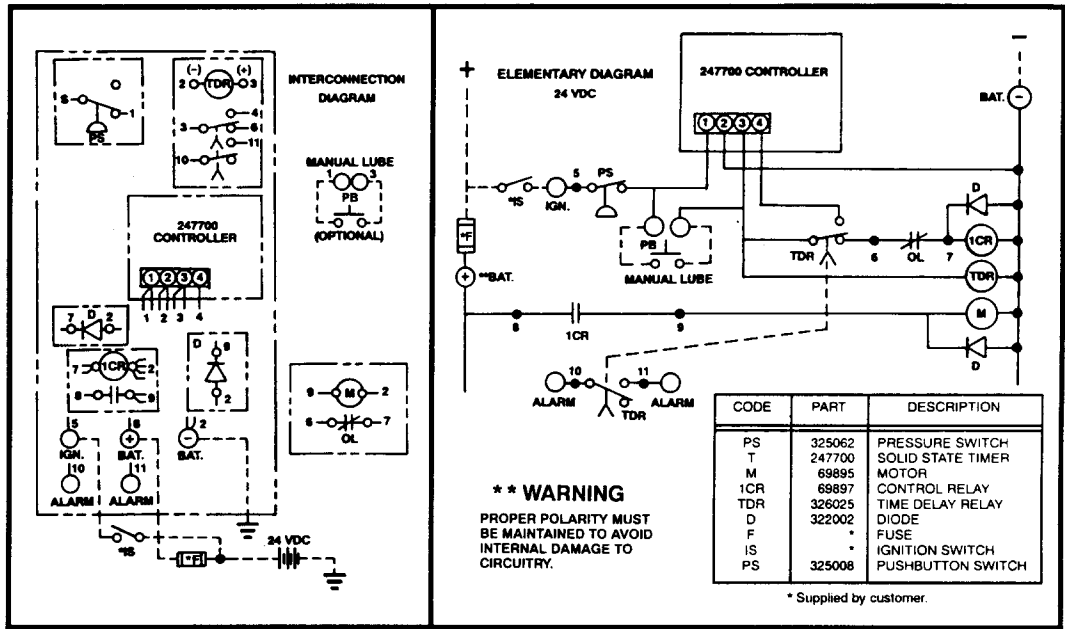

SEQUENCE OF OPERATION: 1833

1. Closing the Ignition Switch (IS) energizes the Timer (T) through the Pressure Switch (PS). After an initial period of time equal to the cycle frequency selected on the timer, the timer energizes an internal relay that supplies power to the Control Relay (ICR) through the Time Delay Relay (TDR) contact and the Overload (OL) contact. This activates the Motor (M) which in turn operates the pump. At the same time, the time delay relay coil is energized and begins timing out (60 sec.).

NOTE: The Diodes (D) serve only to eliminate any A.C. spike initiated by the motor when it is activated.

2. After the desired system pressure is reached, the pressure switch is opened and the timer is reset; the control relay and time delay relay are de-energized. The motor and pump stop and system pressure vents.
3. Should system pressure not be reached within the maximum pumping time of 1 minute, the time delay relay times out stopping the motor and pump. The time delay relay contacts transfer, signalling an external alarm (Supplied by Customer). The unit will remain in alarm until the ignition switch is opened.
4. Closing the ignition switch resets the system.
5. Optional Manual Lube Pushbutton Switch (PB) provided.

DETAIL "C"

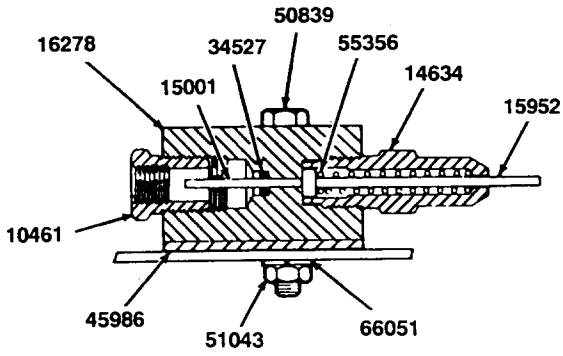

© ASSEMBLE 13461 TO 14058 USING LOCTITE #271 (red) ON THREADS, THEN TORQUE TO 45-55 FT. LBS.

SECTION A-A

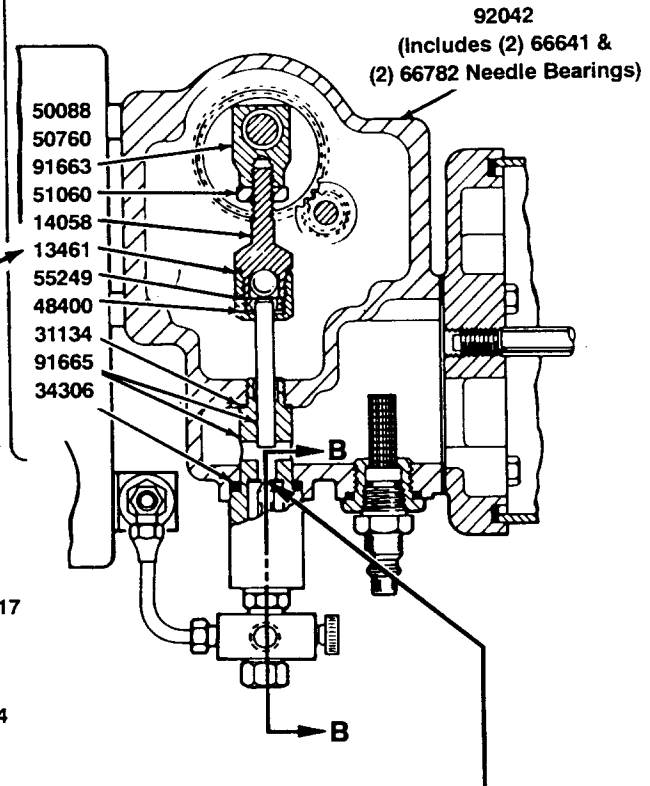

NOTE:

PLUNGER GAP CRITICAL: TO ADJUST, PLACE ECCENTRIC IN FORWARD POSITION. EXTEND PLUNGER ADJUSTMENT UNTIL PLUNGER TOUCHES CHECK SEAT. REVERSE ADJUSTMENT 1/2 TURN.

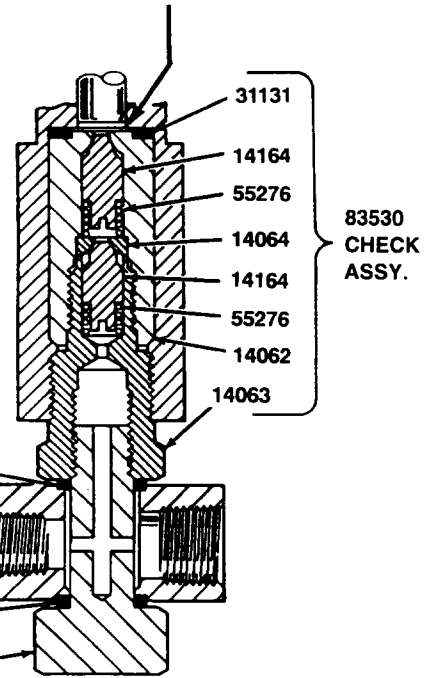
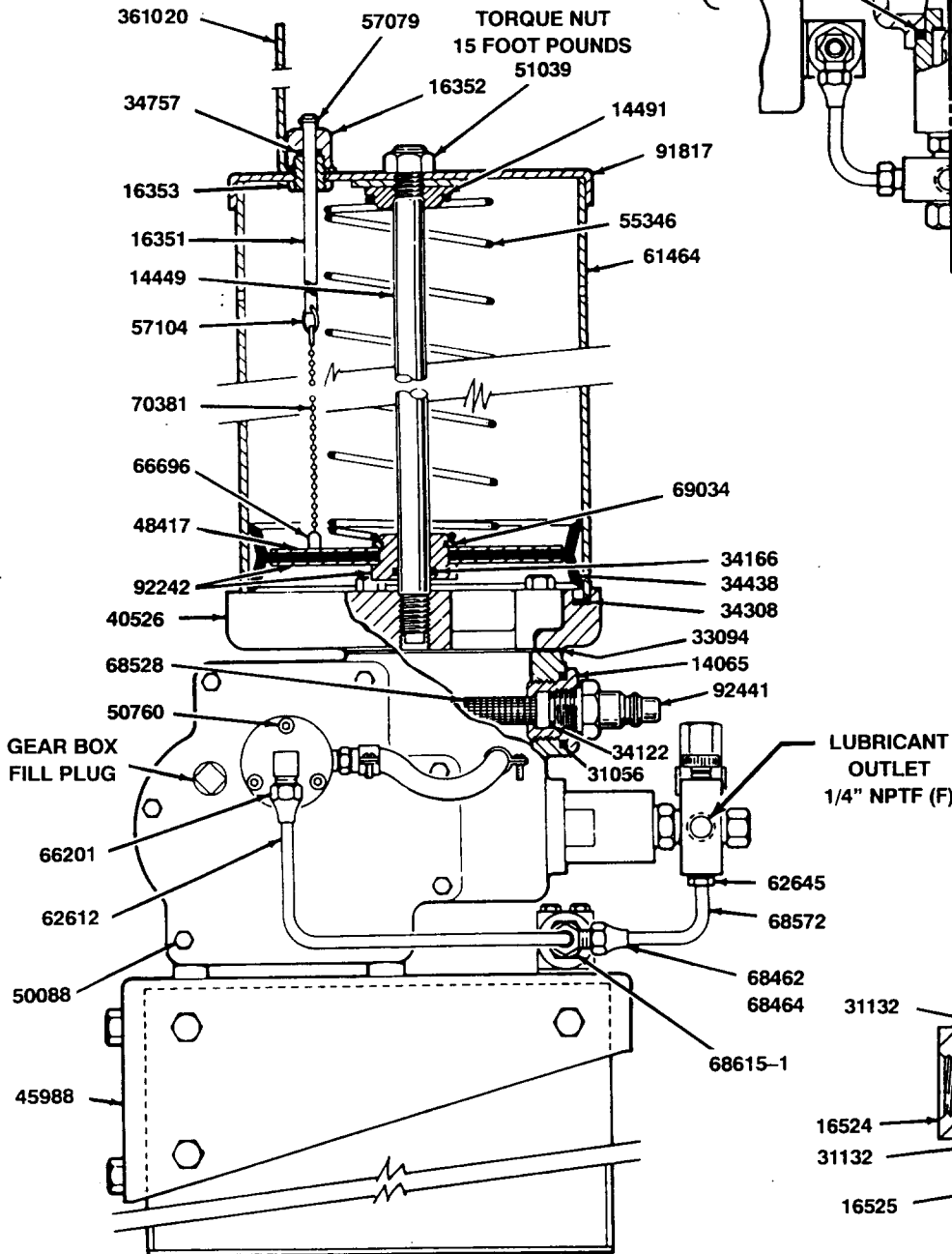

© Indicates Change

SECTION B-B

83477 GEAR BOX ASSEMBLY

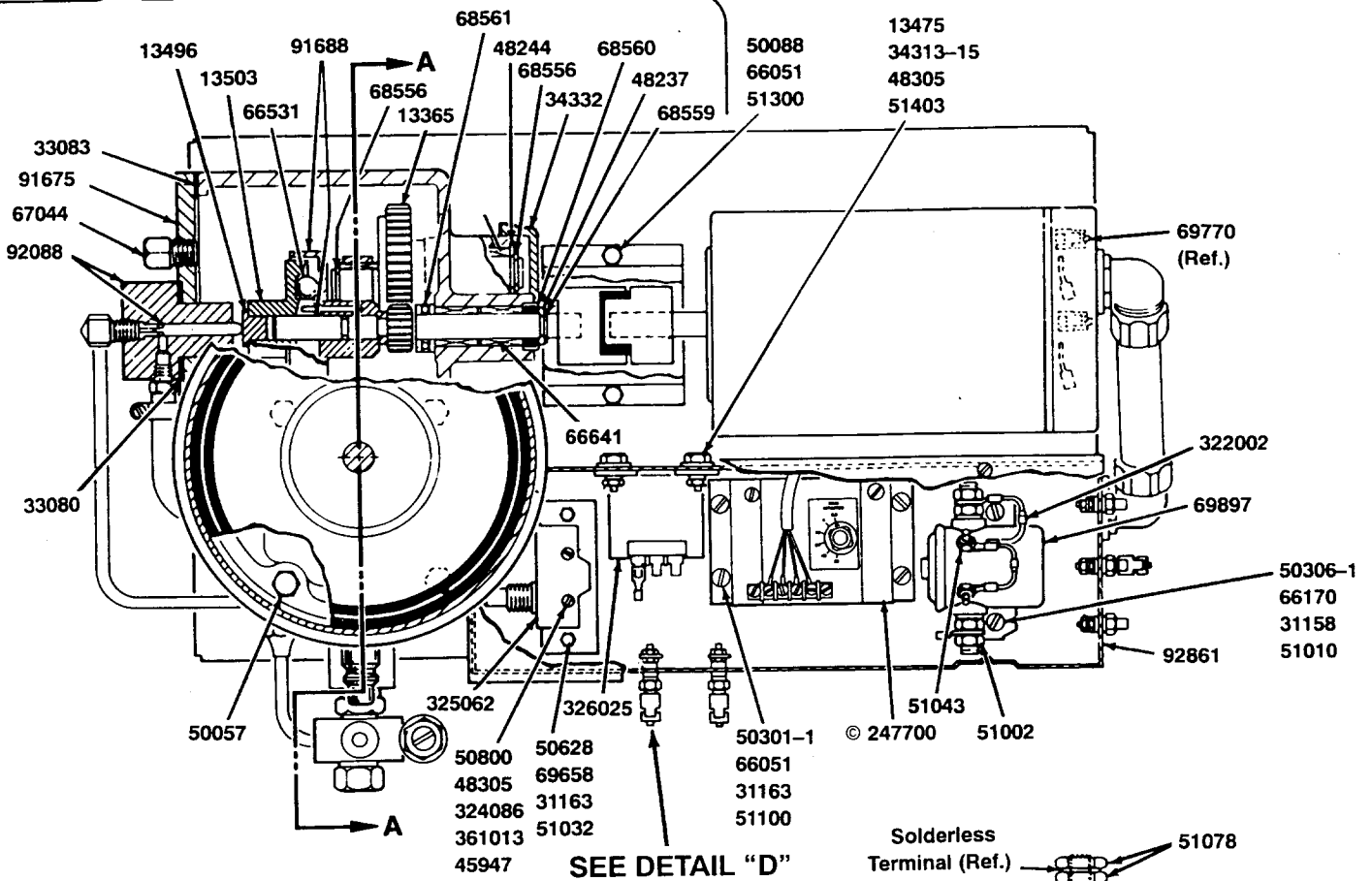

SEE DETAIL "D"

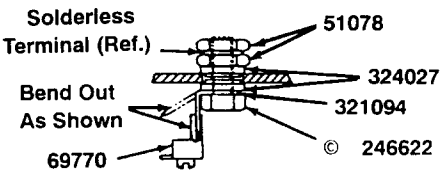

DETAIL "D"

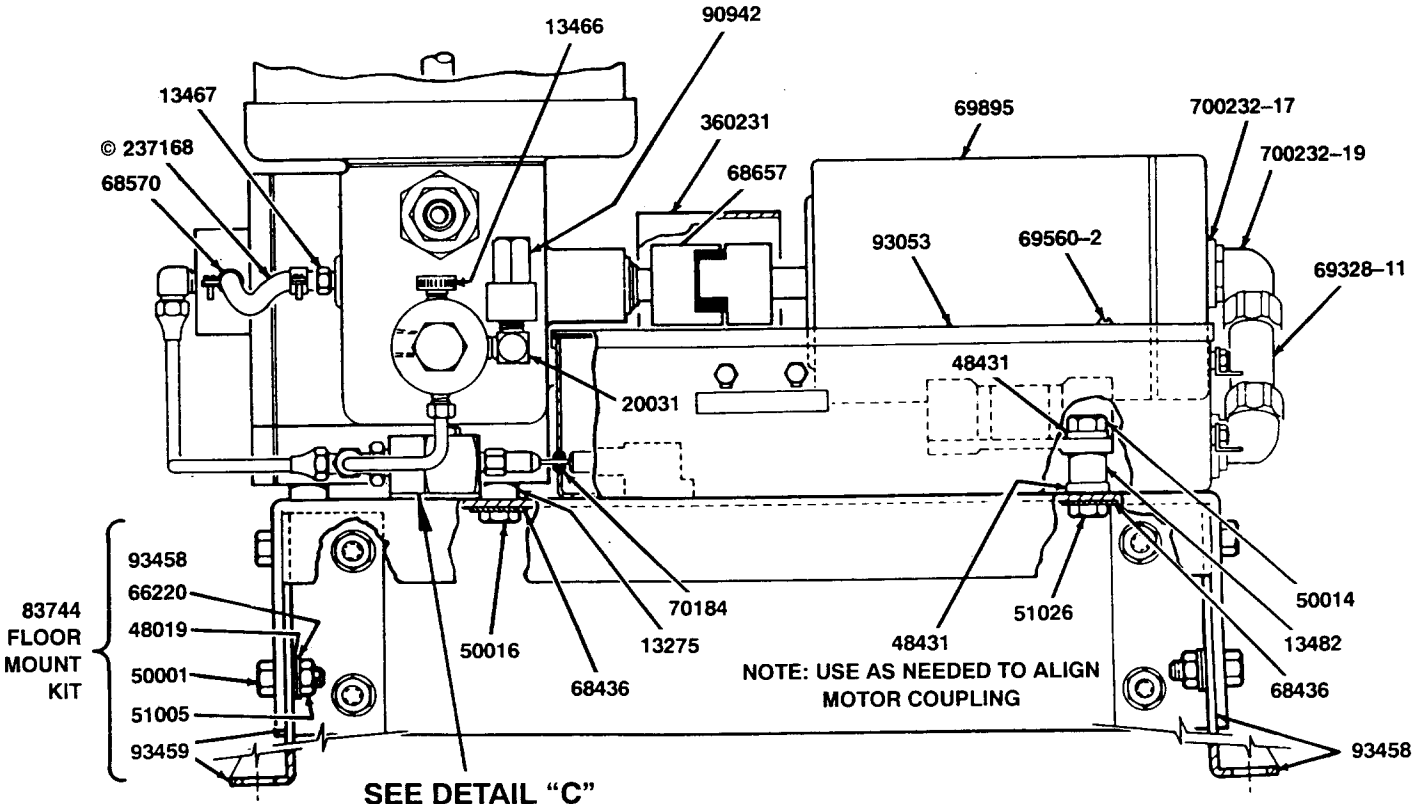

SEE DETAIL "C"

SERVICE PARTS

Part	Qty.	Description	Part	Qty.	Description	Part	Qty.	Description
10461	1	Bushing	48237	1	Washer	68528	1	Strainer
13275	4	Spacer	48244	1	Washer	68556	2	Retaining ring
13365	1	Gear	48305	4	Gasket	68559	1	Retaining ring
13461	1	Nut	48400	1	Washer	*68560	1	Shaft seal
13466	1	Air vent screw	48417	1	Washer	*68561	1	Thrust bearing
13467	2	Fitting	48431	8	Washer	68570	2	Clamp
13475	2	Screw	50001	10	Bolt	68572	1	Tube fitting
13482	4	Spacer	50016	4	Screw	68615-1	1	Tee
*13496	1	Thrust bearing	50057	4	Screw	68657	1	Coupling
*13503	1	Cam	50088	9	Screw	69034	1	Snap ring
14058	1	Connecting rod	50014	4	Screw	69328-11	1	Conduit
14062	1	Body	50301-1	4	Screw	69560-2	4	Screw
14063	1	Cap	50306-1	2	Screw	69658	2	Lockwasher
*14064	1	Seat	50628	2	Screw	69770	9	Terminal
14065	1	Adapter	50760	3	Cap screw	69895	1	Motor
*14164	2	Check valve	50800	2	Screw	69897	1	Solenoid
14449	1	Tie rod	50839	2	Screw	70184	1	Grommet
14491	1	Retainer washer	51002	2	Nut	70381	1	Ball chain
14634	1	Indicator housing	51005	10	Nut	83477	1	Gear box assembly
15001	1	Pin	51010	2	Nut	83530	1	Check assembly
15952	1	Actuator pin	51026	4	Nut	83744	1	Foot mount kit
16278	1	Indicator body	51032	2	Nut	*90942	1	Unloader assembly
16351	1	Indicator rod	51039	1	Nut	91663	1	Crank head assembly
16352	1	Nut	51043	4	Nut	*91665	1	Plunger & bushing
16353	1	Nut	51060	1	Locknut	91675	1	Cover assembly
16524	1	Connector	51078	14	Nut	91688	1	Gear & ball housing
16525	1	Bolt	51100	4	Nut	91817	1	Reservoir cap
20031	1	90° Elbow	51300	2	Nut	92042	1	Gear box
*31056	1	Gasket	51403	2	Nut	*92088	1	Needle & vent body
*31131	1	Gasket	*55249	1	Spring	92242	1	Bushing & washer
*31132	2	Gasket	*55276	2	Spring	92441	1	Filler fitting
*31134	1	Gasket	55346	1	Spring	92861	1	Box
31158	2	Gasket	*55356	1	Spring	93053	1	Cover
31163	6	Gasket	57079	1	Spring clip	93458	1	Bracket (right)
*33080	1	Gasket (Fiber)	57104	1	Ring	93459	1	Bracket (left)
*33083	1	Gasket (Fiber)	61464	1	Reservoir	©237168	1	Hose
*33094	1	Gasket (Fiber)	62612	1	Tube	©246622	7	Screw
*34122	1	Packing (Nitrile)	62645	1	Tube	©247700	1	Timer assembly
*34166	1	O-ring (Nitrile)	66051	8	Lockwasher	321094	7	Tab
*34306	1	Packing (Nitrile)	66170	2	Lockwasher	322002	2	Diode
*34308	1	Gasket (Nitrile)	66201	1	Tube connector	324027	14	Washer
*34332	1	Shaft seal (Nitrile)	66220	10	Lockwasher	324086	1	Paper insulator
34413-15	2	Gasket (Nitrile)	*66531	9	Steel ball	325008	1	Pushbutton switch
34438	1	Follower (Nitrile)	*66641	2	Needle bearing	325062	1	Switch
34527	1	O-ring (Nitrile)	66696	1	Ball chain retainer	326025	1	Relay
34757	1	O-ring (Nitrile)	*66782	2	Needle bearing	360231	1	Coupling guard
40526	1	Reservoir base	67044	1	Plug	361013	1	Bracket
45947	1	Plate	68436	8	Lockwasher	361020	1	Indicator bracket
45986	1	Mounting plate	68462	2	Ferrule	700232-17	2	Gasket
45988	1	Base	68464	2	Nut	700232-19	2	Connector
48019	10	Washer						

* Recommended Service Parts Inventory

RETAIN THIS INFORMATION FOR FUTURE REFERENCE

When ordering replacement parts, list: Part Number, Description, Model Number, and Series Letter.

LINCOLN provides a Distributor Network that stocks equipment and replacement parts