

CENTRO-MATIC CONTROL PANEL

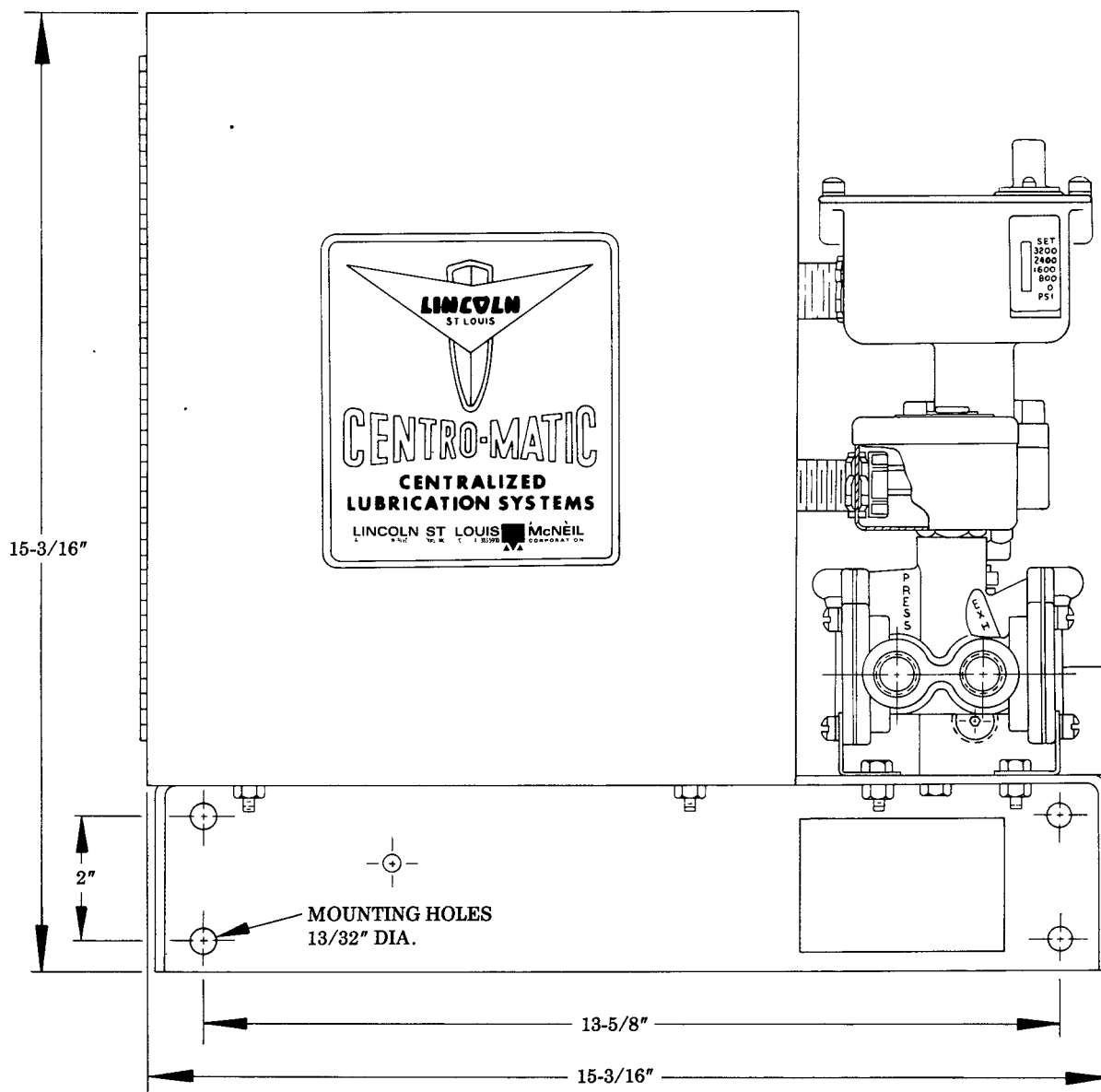

Model 84089 Series "A"



DESCRIPTION

The 84089 is used on systems where airmotor-driven pumps are used. In this case the air supply to pump airmotor is controlled through the air solenoid valve on the control panel. Venting is accomplished through air-operated valve at pump outlet.

ELECTRICAL SPECIFICATIONS

The 84089 is designed for use on 220 Volts, 50 Hertz, Single Phase. Total power required is 55 watts maximum. When panel is in alarm configuration, total power required is 25 watts plus power required to operate external alarm signal.

LINCOLN ST. LOUIS
4010 GOODFELLOW BLVD • ST LOUIS, MO 63120 • (314) 383 5900



A DIVISION OF
McNEIL
CORPORATION

SECTION - **C8**
PAGE - **184**

OPERATION

MODE "A"

When the selector toggle switch is in position "A", a lubrication cycle will begin when power is turned on to the program timer if the timer switch arm isn't being depressed by a clip in the program disc.

At the beginning of a normal lubrication cycle, the solenoid air valve is energized, the vent valve closes and the time delay relay in the program timer begins timing out.

The pump dispenses lubricant into the supply line increasing lubricant pressure until the injectors cycle, then further increases pressure until the control pressure switch is actuated.

The pressure switch energizes the control relay which stops the pump, opens the vent valve and de-energizes the time delay relay, causing it to reset to zero for the next lubrication cycle. The control relay is held energized through one of its contacts and the timer switch so the relay coil will not de-energize when the pressure switch opens as the lubricant pressure vents.

The control relay is de-energized when the timer switch arm is depressed by a clip in the program disc, which is constantly rotated by the timer motor as long as power is on to the program timer.

Subsequent lubrication cycles begin when the timer switch arm is released by the clip in the program disc. The cycle frequency is determined by the number of clips in the inner groove of the program disc.

NOTE: A pre-lube cycle cannot be initiated when power is first turned on if a clip on the disc is positioned to hold down timer switch arm. In this case the first cycle will be initiated when clip moves off actuating arm. Maximum time that clip can hold down arm is 80 seconds (a factory setting).

LUBRICATION FAILURE ALARM

If the time delay relay should time out before pressure switch has actuated, the failure alarm circuits will be activated. Pump stops, energizing the alarm signal terminals. With the alarm signals energized, no more lube cycles can be initiated by the cycle timer and alarm signal will remain energized until power supply to control panel is disconnected.

MONITOR SIGNALS

A monitor, either a horn or a light should be used as a signal for calling attention to the system when it has failed to complete a pumping period within the time for which "alarm timer" is set. A Model 83546 Signal Monitor is available. (A green lamp indicates system is on, amber lamp indicates a lube cycle, and a red lamp lights and horn sounds if system fails to complete a pumping period within the set time.) Refer to Service Manual C8, Page 165 Series.

SERVICE PARTS

PART	QUAN.	DESCRIPTION
10462	1	Nipple
14871	1	Junction block
66645	1	Adapter union
67358	2	Elbow
67417	1	Plug
*69553	1	Solenoid air valve
*69630	1	Pressure switch
84090	1	Program timer

*Recommended service parts inventory.

MODE "B"

When the selector toggle switch is in position "B", no pre-lube cycle is initiated when power is turned on to the program timer. A lubrication cycle begins when the timer switch arm is first depressed and then released by a clip in the inner groove of the program disc.

At the beginning of a normal lubrication cycle the solenoid air valve is energized, the vent valve closes and the time delay relay in the program timer begins timing out.

The pump dispenses lubricant into the supply line increasing lubricant pressure until the injectors cycle, then further increases pressure until the control pressure switch is actuated.

The pressure switch de-energizes the control relay which stops the pump, opens the vent valve and de-energizes the time delay relay causing it to reset to zero for the next lubrication cycle.

The control relay is energized when the timer switch arm is depressed by a clip in the program disc, which is constantly rotated by the timer motor as long as power is on to the program timer. Next lube cycle begins when timer switch arm is released by the clip.

Subsequent lubrication cycles begin when the timer switch arm is depressed and then released by a clip in the program disc. The cycle frequency is determined by the number of clips in the inner groove of the program disc.

MODEL 69630 PRESSURE SWITCH

IMPORTANT

The 69630 Pressure Switch is factory set at 2500 psi for normal high pressure grease systems.

For low pressure oil systems, pressure switch **MUST** be reset for 850 psi.

To lower the actuation pressure, turn the self-locking adjustment screw clockwise. To raise the actuation pressure, turn the adjustment screw counter-clockwise.

NOTE:

Pressure switch is provided with a scale indicating pressure in "Bars" as well as lbs. per sq. in. "Bar" is the metric unit of measure for pressure.

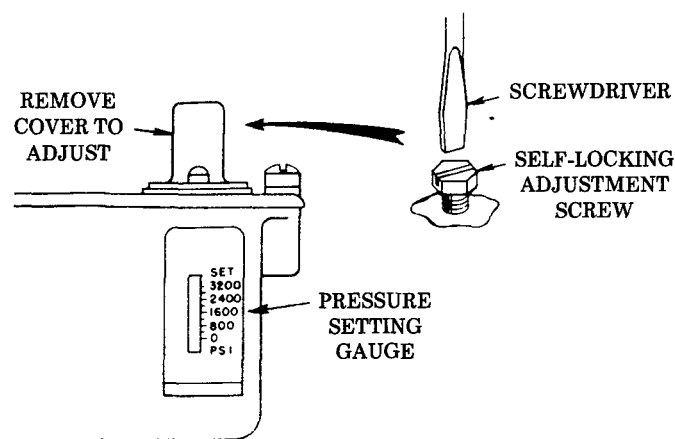

MODEL 84089 MASTER CONTROL PANEL

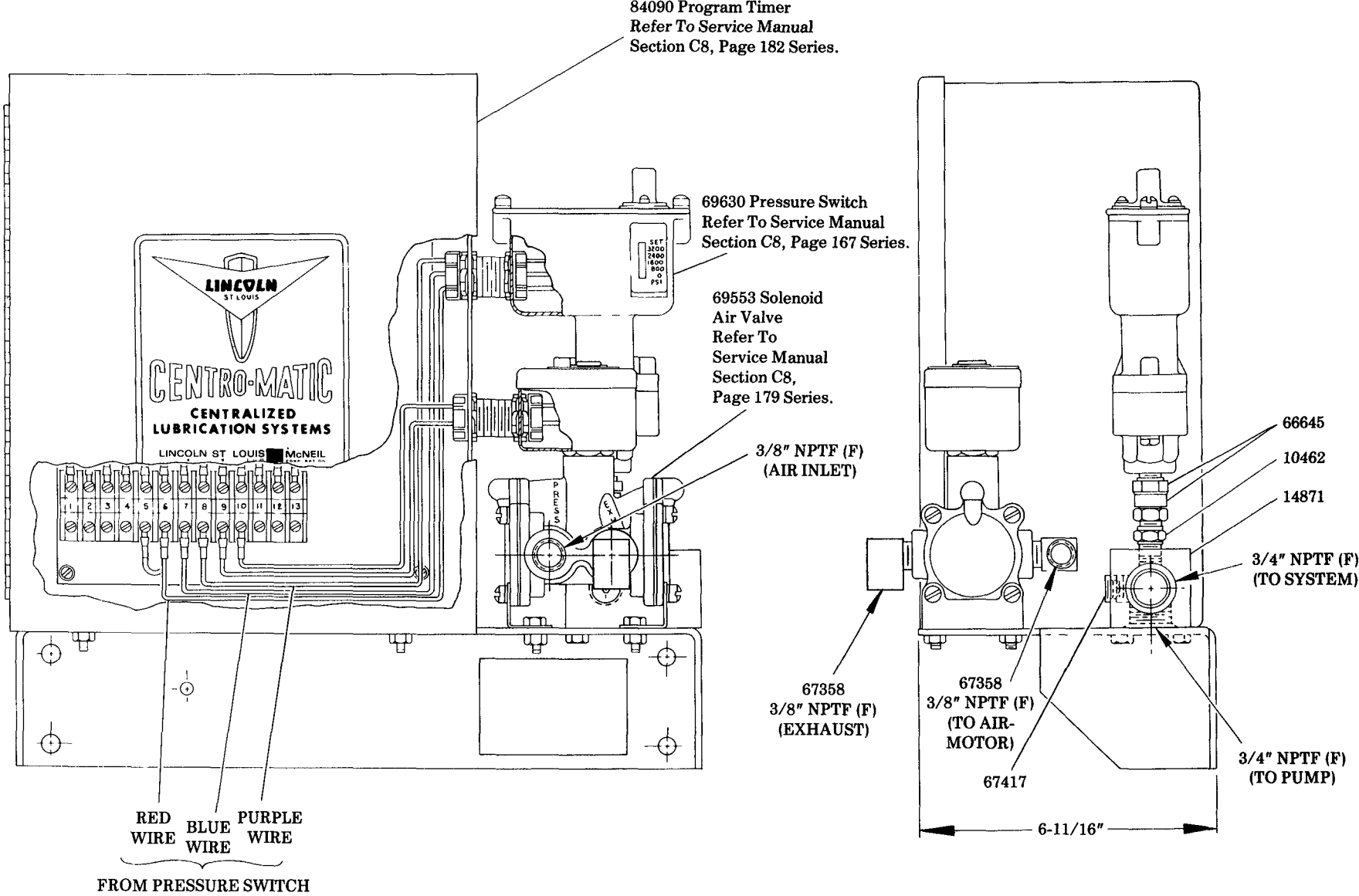

ELEMENTARY DIAGRAM

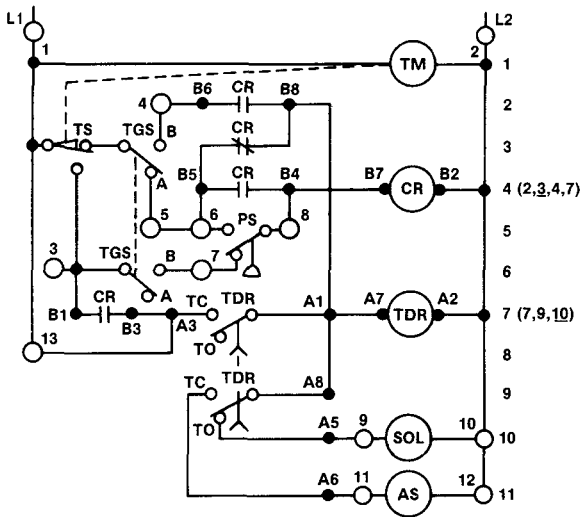

NOTE: Numbered open circles on diagrams identify corresponding numbered terminals on timer.

POSITION DIAGRAM

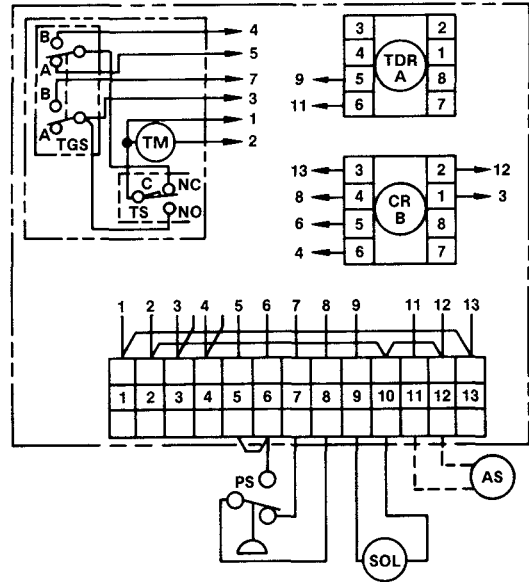

SEQUENCE OF OPERATION

- (1) Toggle Switch (TGS) in position "A", power "on" energizes Time Delay Relay (TDR) coil, line 7, through contacts Timer Switch (TS), TGS and Control Relay (CR), line 3, and Solenoid Air Valve (SOL) through TDR, line 10. TDR begins to time out and pump delivers lubricant.
- (2) Pressure raises, actuating Pressure Switch (PS) contacts, line 5, to energize CR coil, line 4, opening CR contacts, line 3, and closing CR contacts, line 4. TDR resets, pump stops, pressure vents, but CR remains energized. TS, line 3, is actuated by Timer Motor (TM) to de-energize CR coil. Next lube cycle starts when TM releases TS. Operation follows steps 1 and 2 above.
- (3) TGS in position "B", TS, line 3, is actuated by TM, energizing CR coil, line 4, through "B" of TGS and PS, line 6. When TM releases TS, CR coil is held energized through CR contacts, line 7, and PS, line 6. TDR coil is now energized through "B" of TGS, line 3, and CR contacts, line 2. SOL is also energized through TDR contacts, line 10. TDR begins to time out and pump delivers lubricant. Pressure raises in lube supply line.
- (4) PS actuates, de-energizing CR coil, line 4. CR contacts, line 2, open, de-energizing TDR and pump stops, pressure vents and TDR resets. Operation follows as in 3 and 4.
- (5) If TDR times out before PS actuates, TDR contacts, line 7, close, holding TDR timed out. TDR contacts, line 9, close, energizing Alarm Signal (AS), line 11, and TDR contacts, line 10, open, stopping pump. Power must be interrupted to release TDR coil and restore system operation.

NOTE: Time delay relay should be set 30 seconds longer than required pumping time.

CODE	PART	DESCRIPTION
TM	PART OF	TIMER MOTOR
TS	84092	TIMER SWITCH
TGS	TIMER	TOGGLE SWITCH
TDR	69637	TIME DELAY RELAY
CR	69638	CONTROL RELAY
PS	69630	PRESSURE SWITCH
SOL	69533	SOLENOID AIR VALVE
AS	*	ALARM SIGNAL

*Supplied by customer.

RETAIN THIS INFORMATION FOR FUTURE REFERENCE

When ordering replacement parts, list: Part Number, Description, Model Number, and Series Letter.

LINCOLN ST. LOUIS provides a Distributor Network that stocks equipment and replacement parts.

A list of Authorized Service Departments will be furnished upon request.