

HYDRAULIC CONTROL PANEL

24 VOLT DC

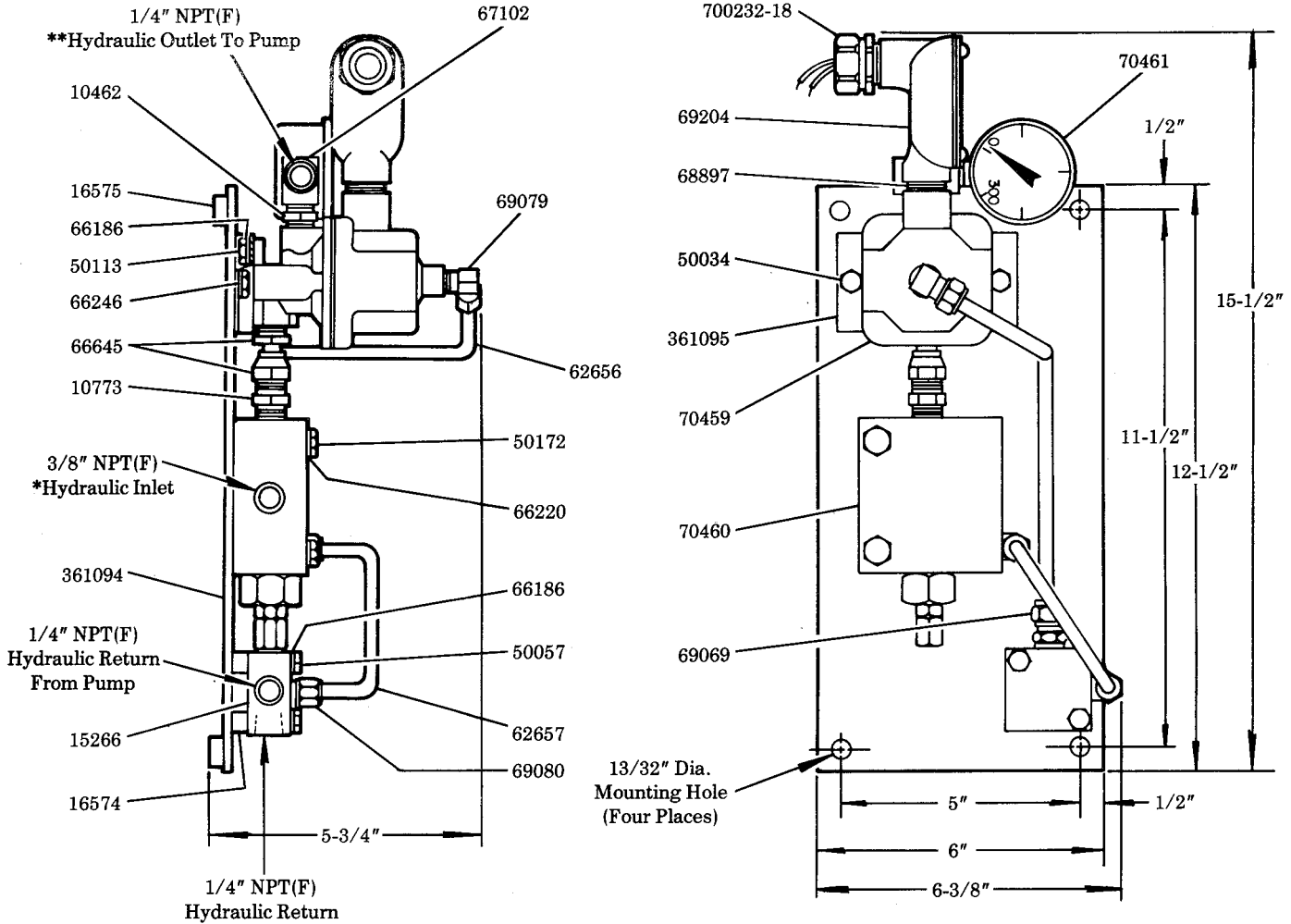

Model 84615



SPECIFICATIONS:

*HYDRAULIC INLET PRESSURE: 2000 PSI Max.

**HYDRAULIC OUTLET PRESSURE: 25 Min. - 200 Max. PSI.

SOLENOID VALVE VOLTAGE: 24 VDC, 14 Watts

PRESSURE REDUCER PILOT FLOW: 10-15 Cu. In./Min.

SERVICE PARTS

PART	QUAN.	DESCRIPTION	PART	QUAN.	DESCRIPTION
10462	1	Nipple	66645	1	Union
10773	1	Nipple	67102	1	Pipe tee
15266	1	Cross	68897	1	Nipple
16574	2	Spacer	69069	1	Tube connector
16575	4	Spacer	69079	1	Tube connector
50034	2	Screw	69080	2	Tube connector
50057	2	Screw	69204	1	Conduit elbow
50113	2	Screw	70459	1	3-Way solenoid valve
50172	2	Screw	70460	1	Pressure reducing valve
62656	1	Tube	70461	1	Pressure gauge
62657	1	Tube	361094	1	Mounting plate
66186	4	Lockwasher	361095	1	Bracket
66220	2	Lockwasher	700232-18	1	Conduit connector
66246	2	Lockwasher			

LINCOLN ST. LOUIS
4010 GOODFELLOW BLVD. • ST. LOUIS, MO. 63120 • (314) 679-4200



A DIVISION OF
McNEIL
CORPORATION

SECTION - **C8**
PAGE - **201A**