

IMPORTANT
MAXIMUM HYDRAULIC OIL TEMPERATURE: 210° F.
(If higher temperature is required, contact factory).

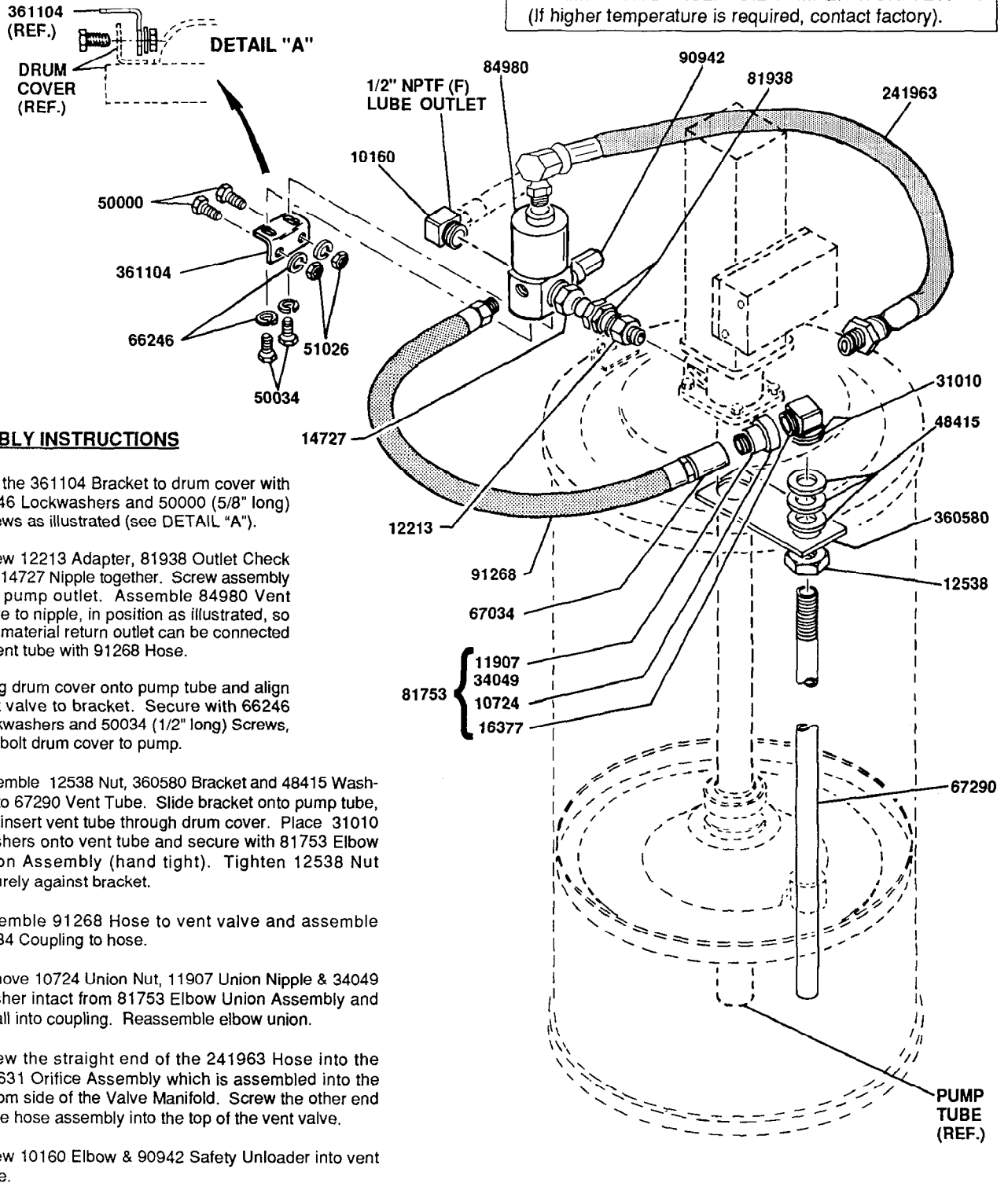

ASSEMBLY INSTRUCTIONS

- 1) Bolt the 361104 Bracket to drum cover with 66246 Lockwashers and 50000 (5/8" long) Screws as illustrated (see DETAIL "A").
- 2) Screw 12213 Adapter, 81938 Outlet Check and 14727 Nipple together. Screw assembly into pump outlet. Assemble 84980 Vent Valve to nipple, in position as illustrated, so that material return outlet can be connected to vent tube with 91268 Hose.
- 3) Bring drum cover onto pump tube and align vent valve to bracket. Secure with 66246 Lockwashers and 50034 (1/2" long) Screws, and bolt drum cover to pump.
- 4) Assemble 12538 Nut, 360580 Bracket and 48415 Washers to 67290 Vent Tube. Slide bracket onto pump tube, and insert vent tube through drum cover. Place 31010 Washers onto vent tube and secure with 81753 Elbow Union Assembly (hand tight). Tighten 12538 Nut securely against bracket.
- 5) Assemble 91268 Hose to vent valve and assemble 67034 Coupling to hose.
- 6) Remove 10724 Union Nut, 11907 Union Nipple & 34049 Washer intact from 81753 Elbow Union Assembly and install into coupling. Reassemble elbow union.
- 7) Screw the straight end of the 241963 Hose into the 242631 Orifice Assembly which is assembled into the bottom side of the Valve Manifold. Screw the other end of the hose assembly into the top of the vent valve.
- 8) Screw 10160 Elbow & 90942 Safety Unloader into vent valve.

84980 VENT VALVE

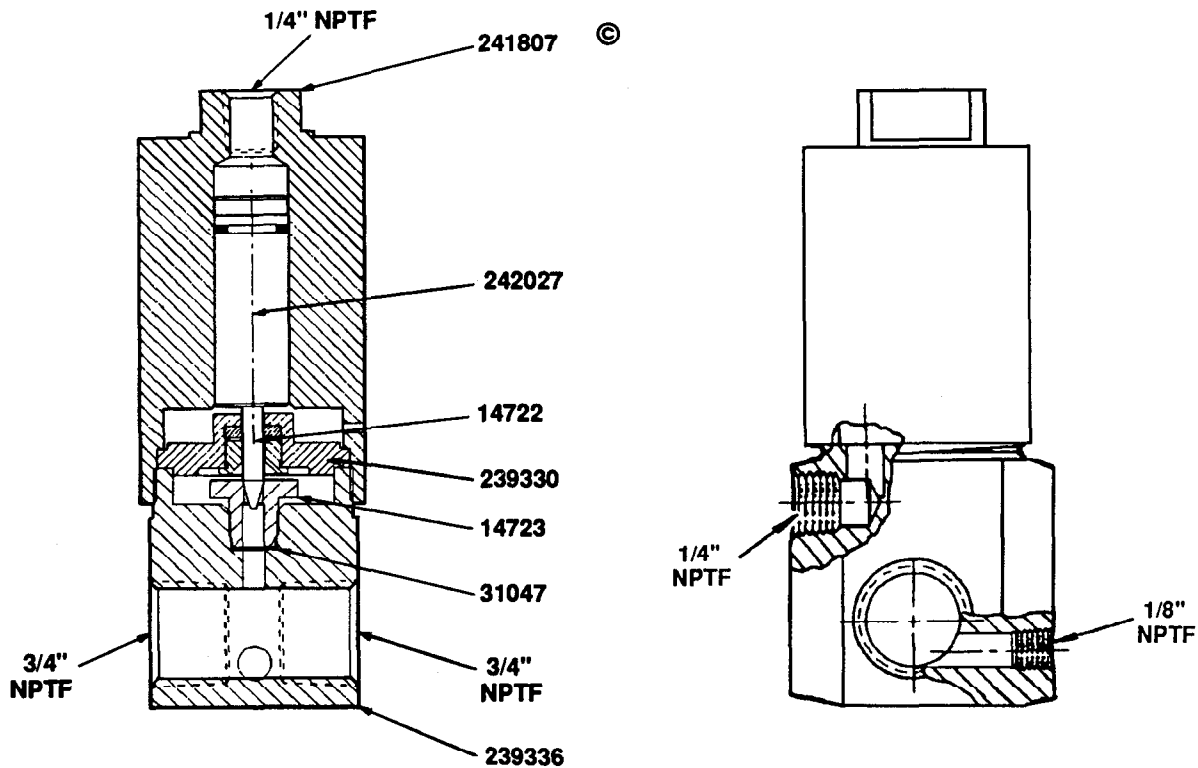

NOTE:

Old-style vent valves used a stop pin above 242027 Piston Assembly. This pin is unnecessary and may be discarded without adverse effect.

© Indicates Change

SERVICE PARTS

Part	Qty.	Description	Part	Qty.	Description
10160	1	Elbow	51026	2	Nut
10462	1	Nipple	66246	4	Lockwasher
10724	1	Union nut	67034	1	Coupling
11907	1	Union nipple	67290	1	Vent tube
12213	1	Adapter	81753	1	Elbow union assembly
12538	1	Nut	81938	1	Outlet check
14722	1	Needle	90942	1	Safety unloader
14723	1	Valve seat	91268	1	Hose
14727	1	Nipple	239330	1	Packing assembly
16377	1	Check housing	239336	1	Valve body
31010	2	Washer (copper)	241807	1	Cylinder
31047	1	Check seat gasket	241963	1	Hose assembly
34049	1	Washer	242027	1	Piston assembly
48415	3	Washer (steel)	360580	1	Bracket
50000	2	Screw	361104	1	Bracket
50034	2	Screw			

RETAIN THIS INFORMATION FOR FUTURE USE

When ordering replacement parts, list: Part Number, Description, Model number, and Series Letter. LINCOLN ST. LOUIS provides a Distributor Network that stocks equipment and replacement parts. A list of Authorized Service Departments will be furnished upon request.