

## SENSOR CONTROLLER - EXTERNAL SCAN OWNER/OPERATOR MANUAL

It is the responsibility of the Owner/Operator to properly use and maintain this equipment

The Instructions and Warnings contained in this manual shall be read and understood by the Owner/Operator prior to operating this equipment

It is the responsibility of the Owner/Operator to maintain the legibility of all Warning and Instruction labels

**The Owner/Operator shall retain this manual for future reference to important Warnings, Operating and Maintenance Instructions.**

| CONTENTS                | PAGE |
|-------------------------|------|
| Description             | 1    |
| Liquid Crystal Display  | 2    |
| Programming Mode        | 2    |
| Run Mode                | 4    |
| Alarm Messages          | 4    |
| Installation of Sensors | 5    |
| Field Connections       | 6    |
| Service Parts           | 7    |
| Specifications          | 8    |
| System Accessories      | 8    |

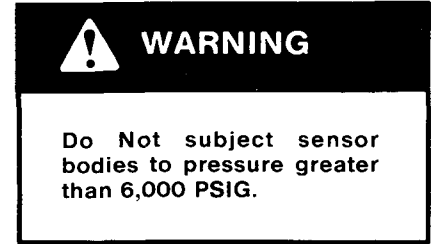
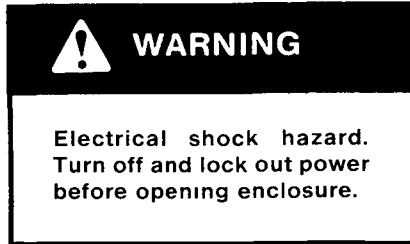

### DESCRIPTION

When programmed as a Sensor Controller, Model 84530 will verify delivery of lubricant into a bearing

The Sensor Controller can only detect faults which occur between the sensor (located in the delivery line at the bearing lube inlet) and the flow source. Continuous flow or no flow during the delivery cycle are both signaled as a fault by this system. A minimum of 30 seconds between the end of one flow to the beginning of the next flow is required for detection.

Sensors will function at any pressure up to 6,000 PSIG. The temperature of the material which is to be delivered past the sensors must be between 32° F to 145° F for effective operation of the system. Viton seals and checks in the sensors allow their use in systems distributing synthetic lubricants as well as petroleum based lubricants. **For reliable operation, sensors can only be used with Model 84530.**

**When power is turned on to the Controller and a Lube cycle is immediately initiated, a sensor fault may occur due to the sensors not having enough time to warm. It is recommended that the Delay Alarm be set at 2 in order to prevent a nuisance alarm.**

An external switch (contact closure) or an external signal (120/230 VAC) will initiate a scan period (amount of time that the sensors are scanned for lube flow). The scan period is the time that the external switch is closed.

When the external switch closes the amber light turns on and the timer on the display begins timing up from zero, indicating the amount of time the external switch has been closed. If the sensors are satisfied while the external switch is closed the amber light will turn off. When the external switch opens the timer on the display is reset to zero and begins timing up again, indicating how long since the last scan period

If the sensors are not satisfied while the external switch is closed the following will happen:

- Amber light on door remains on.
- The timer on the screen is reset to zero and begins timing up indicating when the last scan period took place.

If, after thirty seconds following the external switch opening, the sensors still have not been satisfied and the delay alarm counter has reached its set value the following will happen

- Red light on door turns on
- Alarm relay contact closes
- Alarm message will alternate with Scan Timer on enclosure door

If lube flow takes place while the external switch is open, the fault will be cleared. However, the next time the external switch closes the amber light will not turn on

Due to the numerous options available, the customer can field program the controller to match the system requirements. Programming is easily accomplished by following a user friendly menu displayed on the LCD and pressing the active buttons beneath the display. An internal jumper pin provides security against unauthorized programming. All programmed parameters are automatically stored in a nonvolatile memory. A Review Screen can be easily activated to display what has been programmed. Programmed values can be changed whenever necessary.

There are three lights on the enclosure door to indicate the status of the system

- Green** - Power On
- Amber** - Sensors are waiting to be satisfied.
- Red** - Alarm

If an alarm occurs, the cause of the alarm will appear on the LCD. Turning off power to the controller when in alarm will reset the alarm.

The LCD is capable of displaying the following messages

- Amount of elapsed time since the External switch opened
- Amount of elapsed time that the External switch has been closed
- Number of times each bearing has received lube
- Indicates what sensor did not receive lube
- Indicates what sensor has a broken wire
- Indicates what sensor has a shorted wire

## LIQUID CRYSTAL DISPLAY

The LCD has a bottom to top viewing angle. It is recommended that the controller be mounted slightly above eye level for optimum viewing.

The first line of the LCD is an instruction line or a message. The second line can have up to four commands, each corresponding to the button beneath it. Pressing the corresponding button will invoke that command.

The following example shows the MAIN MENU

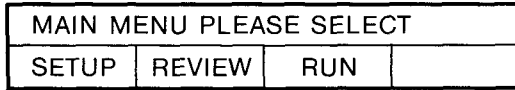

**SETUP** - Pressing the button beneath SETUP will display the SETUP MENU

**REVIEW** - Pressing the button beneath REVIEW will display the REVIEW SCREENS

**RUN** - Pressing the button beneath RUN will cause the controller to function as it was programmed in the SETUP MENU

## PROGRAMMING MODE

To program a new controller, use the following example as a guide to match the controller to your system requirements. The internal jumper pin will be in the Program position for a new controller.

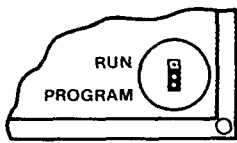

JUMPER IN "PROGRAM" POSITION

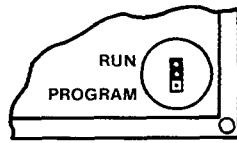

JUMPER IN "RUN" POSITION

If a controller already in use needs to be reprogrammed, the internal jumper pin must be moved from the Run position to the Program position. **WARNING: Turn power off before opening enclosure door to move jumper pin.**

If no buttons are pressed within a 30 second period, the display will automatically change to "SET JUMPER TO RUN". Pressing the button under "<" will display the MAIN MENU.

### EXAMPLE:

The following instructions will illustrate how to program a Sensor Controller - External Scan with these sample parameters.

| STEP |                            |       |
|------|----------------------------|-------|
| 4    | USING SENSORS ?            | YES   |
| 5    | LUBE & SENSOR CONTROLLER ? | NO    |
| 6    | SENSOR CONTROLLER ONLY ?   | YES   |
| 7    | EXTERNAL INPUT FOR SCAN ?  | YES   |
| 8    | ACTIVATE SENSOR INPUTS     | 1 & 3 |
| 9    | ALARM IMMEDIATE OR DELAY ? | DELAY |
| 10   | NUMBER OF FAULT DELAYS     | 2     |

1) Reminder that if the Run Mode is desired the jumper must be set to Run

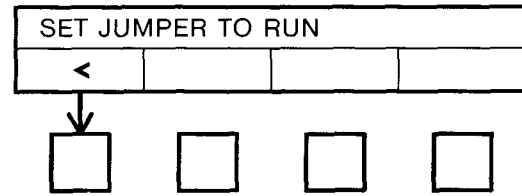

Press button under "<".

2) Main Menu options

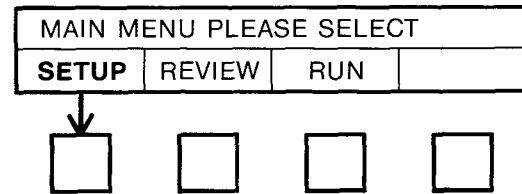

**SETUP** - All programming options are available in the Setup Menu

**REVIEW** - Can review all system parameters that have been programmed in the Setup Menu

**RUN** - Controller will function as it was programmed in the Setup Menu

Press button under "SETUP".

3) Setup Menu options.

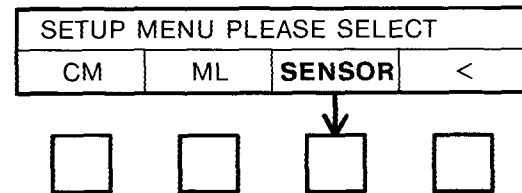

**CM** - Programming options for a Centro-Matic Controller (see CM Manual)

**ML** - Programming options for a Modular Lube Controller (see ML Manual)

**SENSOR** - Programming options for a Sensor Controller

< - Will return you to the previous screen

Press button under "SENSOR".

4) Choice of using sensors.

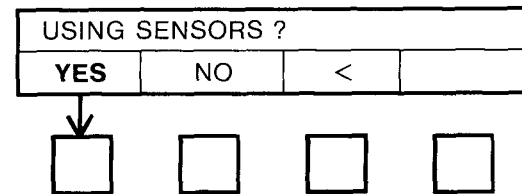

**YES** - Confirms that you are using sensors

**NO** - Returns you to the Main Menu

< - Returns you to the Setup Menu

Press button under "YES".

5) Determines if this is a Lube & Sensor controller

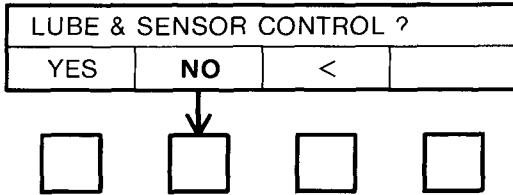

**YES** - The controller will function as both a Lube & Sensor controller (refer to Centro-Matic or Modular Lube Manuals for information on Lube programming)

**NO** - Sensor controller only

< - Previous screen

Press button under "NO".

6) Confirms that this is only a Sensor Controller

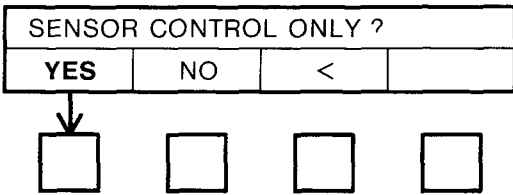

**YES** - Confirms that this is only a Sensor Controller

**NO** - Returns to the "USING SENSORS ?" display

< - Previous screen

Press button under "YES".

7) Determines if an external signal, either a contact closure at terminal strip B terminals 15 & 16 or 120/230 VAC at terminal strip A terminals 5 & 6, will initiate a scan period

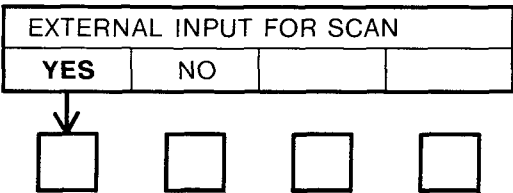

**YES** - External signal will initiate a scan period

**NO** - Internal scan timer will initiate a scan period (Refer to Sensor Controller - Internal Scan Manual)

Press button under "YES".

8) Activates sensor inputs one thru sixteen.

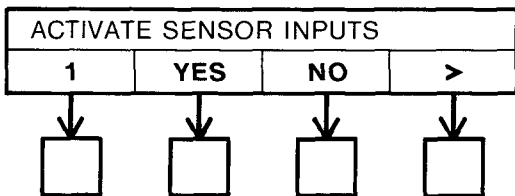

Pressing the first button will increment the number above it by one

**First Button** - Determines sensor input number, 1 thru 16

**YES** - Pressing this button indicates that a sensor is connected to the sensor terminals that correspond with the sensor input number above the first button (see Field Connections)

8) cont

**NO** - Pressing this button indicates that a sensor will not be connected to the sensor terminals that correspond with the sensor input number above the first button (see Field Connections) **All sensor inputs that are not used must be set to "NO".**

> - Next screen

Press first button until a 1 appears.

Then press button under "YES".

Press first button until a 2 appears.

Then press button under "NO".

Press first button until a 3 appears.

Then press button under "YES".

Repeat for sensor inputs 4 thru 16

pressing button under "NO" for each input.

Press button under ">"

9) Option of delaying a sensor alarm. The delay prevents nuisance alarms due to air entrapment in the lube lines and allows sensors to warm when first turning power on to the controller. It is recommended that the Delay Alarm be set to 2

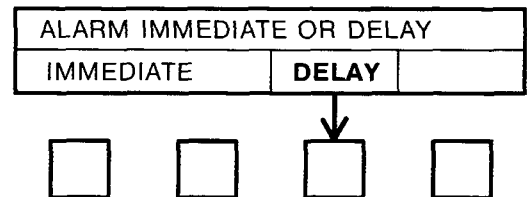

**IMMEDIATE** - The controller will recognize a sensor alarm immediately Same as setting the Delay Alarm to 1

**DELAY** - When a sensor alarm occurs the controller will mask it and increment the Delay Alarm Counter by one per lube cycle. Once the preset number for the Delay Alarm Counter has been reached then an alarm will occur.

The Delay Alarm Counter is reset after all of the sensors have received lube

Press button under "DELAY".

10) Determines the number of fault cycles (maximum of 99) that can occur before an alarm

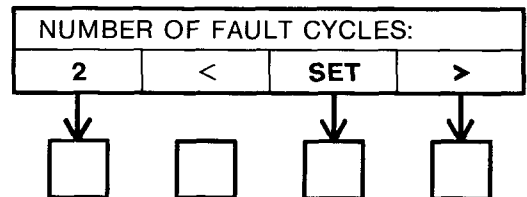

**First Button** - Increments the number of fault cycles by one.

< - Decrements the number of fault cycles by one.

**SET** - Stores the number of fault cycles displayed on screen.

> - Next screen

Press first button until a "2" appears.

Press button under "SET".

Press button under ">".

11) When programming is complete, set internal jumper pin to the Run position **WARNING: Turn power off before opening enclosure door to move jumper pin.**

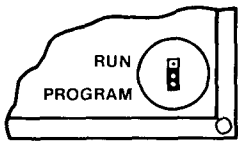

JUMPER IN "PROGRAM" POSITION

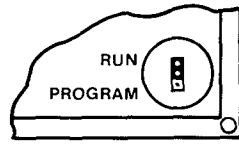

JUMPER IN "RUN" POSITION

## RUN MODE

To access the Run Mode the internal jumper must be in the Run position **WARNING: Turn power off before opening enclosure door to move jumper pin.**

If no pushbuttons are pressed within 30 seconds, while in the Main Menu options, the controller will enter the RUN MODE

The following screens can appear when in the Run Mode

### Main Menu Options

|                         |        |     |  |
|-------------------------|--------|-----|--|
| MAIN MENU PLEASE SELECT |        |     |  |
| SETUP                   | REVIEW | RUN |  |



**SETUP** - All programming options are available in the Setup Menu

**REVIEW** - Can review all system parameters that have been programmed in the Setup Menu

**RUN** - Controller will function as it was programmed in the Setup Menu

Until the first closure of the external scan switch or external scan signal is received, the scan timer will remain at zero Whenever the external switch opens or closes, the scan timer is reset to zero and begins timing up

*External Switch Open* Timer indicates amount of time that has elapsed since the last scan period

*External Switch Closed* Timer indicates amount of time that the external switch has been closed

|                 |        |  |      |
|-----------------|--------|--|------|
| LAST EXT'L SCAN | 20 MIN |  |      |
| SENSOR          |        |  | MENU |



**SENSOR** - Pressing the corresponding button will cause the Sensor screen to appear

**MENU** - Pressing the corresponding button will cause the Main Menu to appear

Indicates the number of lube events that have taken place at each sensor Example screen below shows that 20 lube events have taken place at sensor number 1 There are sixteen separate counters, one for each sensor When lube passes the sensor its corresponding counter will increment by one **When turning power on to the controller, the sensors will warm and the counters may increment by one.**

|                   |       |   |        |
|-------------------|-------|---|--------|
| # OF LUBE EVENTS. | 20    |   |        |
|                   | RESET | < | SNSR 1 |



**RESET** - Pressing the corresponding button will reset all sensor counters to zero

< - Previous screen

**SNSR 1** - Pressing the corresponding button will display the active sensors in ascending order At the same time, line one will indicate the number of lube events for the corresponding sensor on line two

## ALARM MESSAGES:

The following alarm messages can appear if an alarm condition occurs

Indicates that the sensor number appearing did not receive lubricant Alarm relay contact will close and red light on door will turn on

|                      |   |      |        |
|----------------------|---|------|--------|
| NO LUBE FLOW SENSOR. | 1 |      |        |
|                      |   | NEXT | SENSOR |



**NEXT** - Indicates that there is more than one alarm message Pressing the corresponding button will display the next alarm message

**SENSOR** - Pressing the corresponding button will cause the sensor number on line one to increment to the next sensor with the same fault

Indicates that the wire running to the sensor number appearing has opened Red light on door turns on

|                     |   |      |        |
|---------------------|---|------|--------|
| BROKEN WIRE SENSOR. | 1 |      |        |
|                     |   | NEXT | SENSOR |



**NEXT** - Indicates that there is more than one alarm message Pressing the corresponding button will display the next alarm message

**SENSOR** - Pressing the corresponding button will cause the sensor number on line one to increment to the next sensor with the same fault

Indicates that the wire running to the sensor number appearing has shorted Red light on door turns on

|                      |   |      |        |
|----------------------|---|------|--------|
| SHORTED WIRE SENSOR. | 1 |      |        |
|                      |   | NEXT | SENSOR |



**NEXT** - Indicates that there is more than one alarm message Pressing the corresponding button will display the next alarm message

**SENSOR** - Pressing the corresponding button will cause the sensor number on line one to increment to the next sensor with the same fault

## SENSOR INSTALLATION

1 Install male threaded port of Flow Sensor in lube inlet of bearing served

**NOTE:** Flow sensor body contains a check valve, **Do Not Install Backwards.** Lube flow is from 1/8" NPTF Female port to 1/8" NPTF Male port

2 Connect lube line to 1/8" NPTF Female port of flow sensor body

3 Mount 84602 Junction Box at a central location to flow sensors

4 Mount the System Sentry in a convenient location with the LCD and system status lights in full view

5 Connect two conductor sensor wire from first sensor to Terminals 1 & 2, from second sensor to Terminals 3 & 4, etc in the junction box. The numbers on the two terminal strips in the junction box correspond with the numbers on Terminal Strips C & D in the 84530 System Sentry (see Field Connections)

6 On both sets of terminal strips, the two in the junction box and Terminal Strips C & D in Model 84530, the even numbered terminals have been jumped together. This will allow one wire from the twenty conductor cable to act as a common for all of the sensors used

Connect one conductor, from the twenty conductor cable, to an even numbered terminal in the junction box. Connect the other end to an even numbered terminal on Terminal Strips C & D in Model 84530

Use one conductor, from the twenty conductor cable, for each sensor installed. Connect one end of the conductor to the odd numbered terminal, in the junction box, that the sensor is connected to. Connect the other end of the conductor to the corresponding number located on Terminal Strips C & D in Model 84530

**NOTE:** If an 84602 Junction Box is not used the two conductor sensor wire can be wired directly to Model 84530 (see Field Connections)

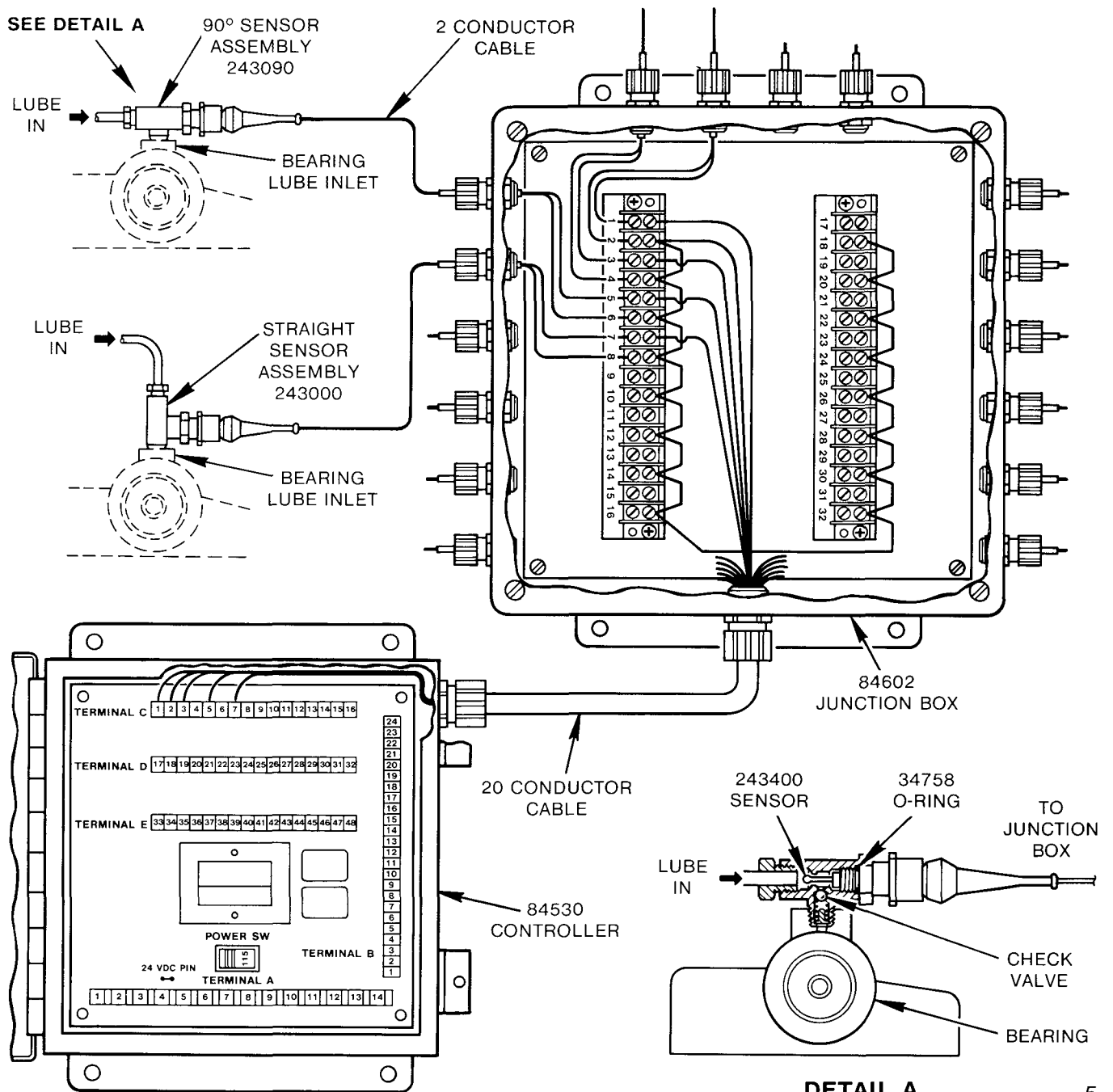

## FIELD CONNECTIONS (Refer To Figure 1)

### TERMINAL STRIP A - HIGH VOLTAGE

#### Incoming Power Source - Terminals 1 & 2.

Connect the black wire to Terminal 1. Terminals 1 and 7 are connected together internally on Terminal Strip A.

Connect the neutral or white wire to Terminal 2. Terminals 2, 9 and 12 are connected together internally.

120 VAC 50/60 Hz. - **Must set power switch to 120 VAC.**  
230 VAC 50/60 Hz. - **Must set power switch to 230 VAC.**

#### External Scan Signal - Terminals 5 & 6.

120/230 VAC Signal.

#### External Alarm Load - Can be used two ways.

- Terminals 10 & 11 - N.O. Contact.
- Using the Controller Line Voltage at Terminals 1 & 2 (see Figure 2).
  - Jumper wire between Terminals 7 & 10.
  - Connect alarm load to Terminals 11 & 12.

360VA Pilot Duty Rating at 120/230 VAC,  
5 amps at 24 VDC.

### TERMINAL STRIP B - LOW VOLTAGE

#### Scan Switch - N.O. Switch, Terminals 15 & 16.

Switch Ampacity 8 MA at 15 VDC.

#### 24 VDC Power - Controller can operate from 24 VDC instead of 120/230 VAC (see Figure 3).

- Cut 24 VDC pin on power supply board.
- Power In: Connect Battery Positive Voltage at Terminal 23. Connect Battery Negative Voltage at Terminal 24.
- Power for Alarm relay contacts: Connect Battery Positive Voltage at **Terminal 1 on Terminal Strip A.** Connect Battery Negative Voltage at **Terminal 2 on Terminal Strip A.**

### TERMINAL STRIP C - Sensors 1 thru 8, Terminals 1 thru 16

- Sensor 1** - Terminals 1 & 2.  
**Sensor 2** - Terminals 3 & 4.  
**Sensor 3** - Terminals 5 & 6.  
**Sensor 4** - Terminals 7 & 8.  
**Sensor 5** - Terminals 9 & 10.  
**Sensor 6** - Terminals 11 & 12.  
**Sensor 7** - Terminals 13 & 14.  
**Sensor 8** - Terminals 15 & 16.

### TERMINAL STRIP D - Sensors 9 thru 16, Terminals 17 thru 32

- Sensor 9** - Terminals 17 & 18  
**Sensor 10** - Terminals 19 & 20.  
**Sensor 11** - Terminals 21 & 22.  
**Sensor 12** - Terminals 23 & 24.  
**Sensor 13** - Terminals 25 & 26.  
**Sensor 14** - Terminals 27 & 28  
**Sensor 15** - Terminals 29 & 30.  
**Sensor 16** - Terminals 31 & 32.

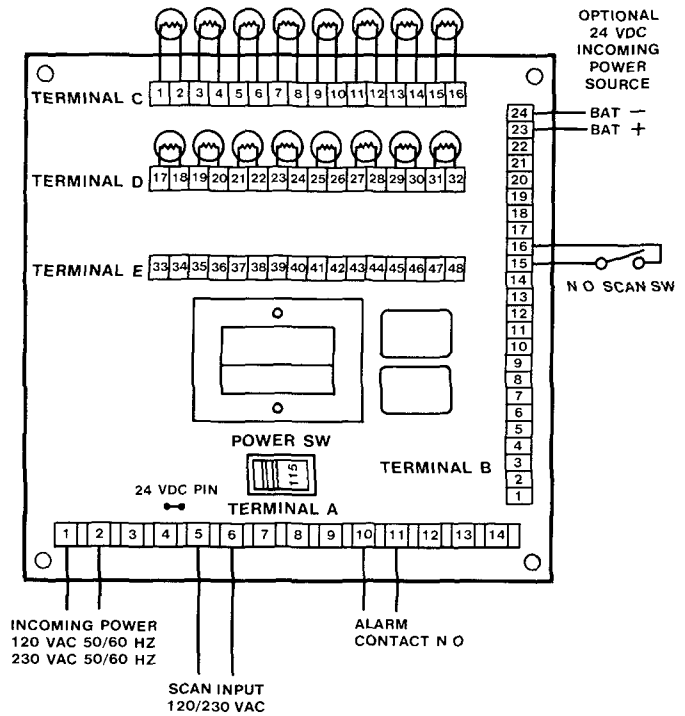

## FIELD CONNECTIONS

Figure 1

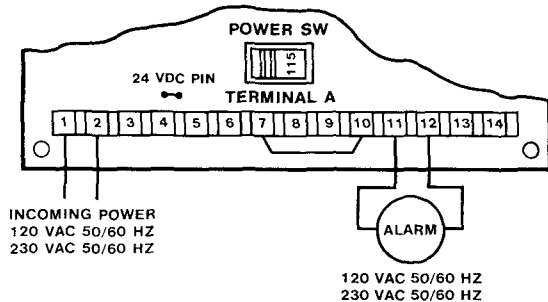

## CONTROLLER LINE VOLTAGE FOR ALARM LOAD

Figure 2

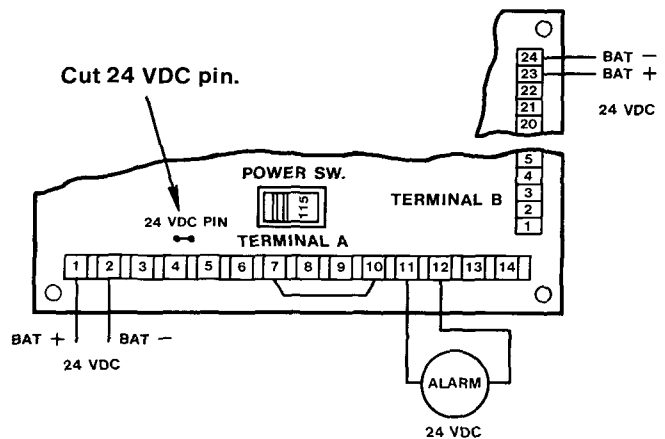

## 24 VDC CONNECTIONS

Figure 3

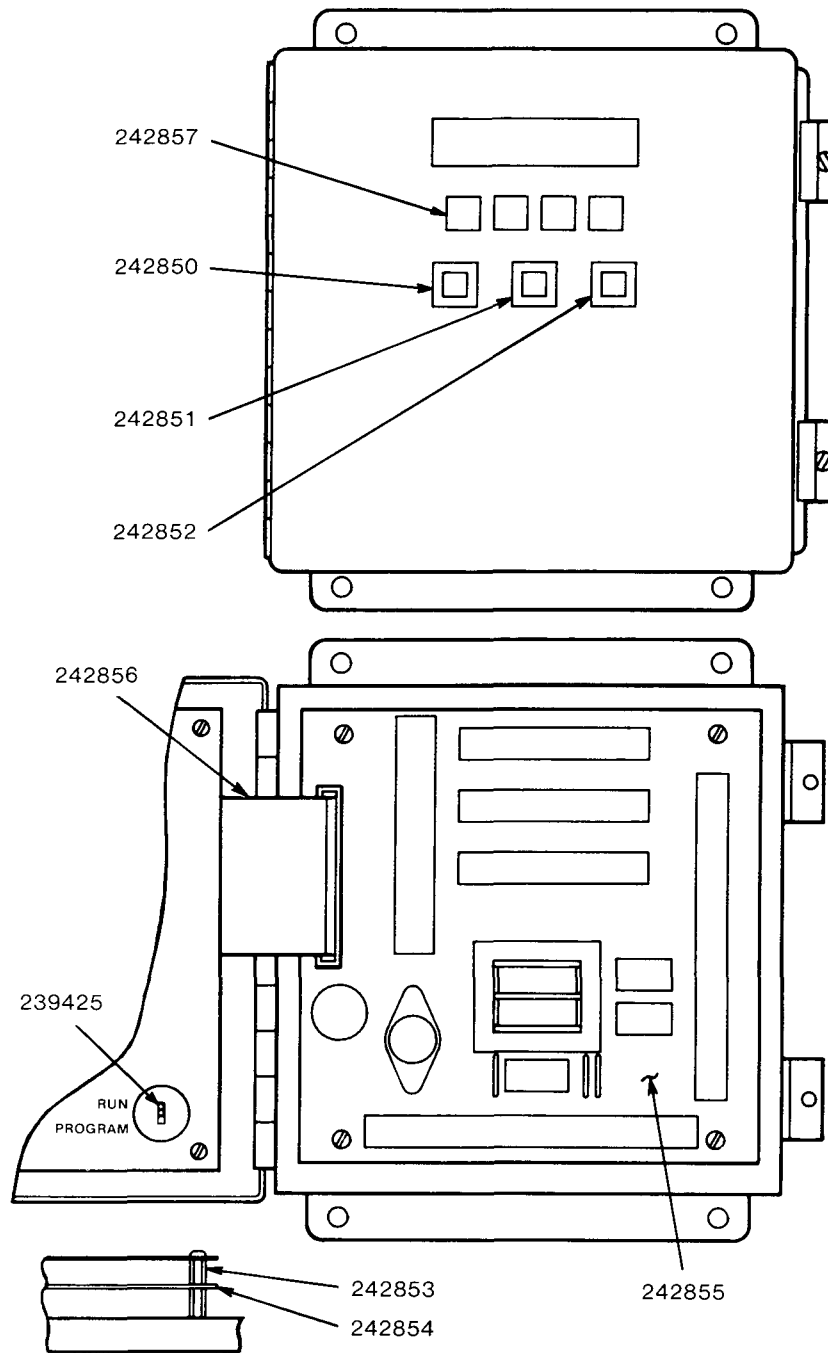

### SERVICE PARTS

| Part                                 | Qty. | Description                             |
|--------------------------------------|------|---|
| 34758                                | 1    | O-ring                                  |
| 239425                               | 1    | Jumper Shunt (strip of ten)             |
| 242850                               | 1    | Green L.E.D., Green Lens & Chrome Bezel |
| 242851                               | 1    | Amber L.E.D., Amber Lens & Chrome Bezel |
| 242852                               | 1    | Red L.E.D., Red Lens & Chrome Bezel     |
| 242853                               | 4    | Standoff & Screw                        |
| 242854                               | 1    | Processor Board Assembly                |
| 242855                               | 1    | Power Supply Board Assembly             |
| 242856                               | 1    | Ribbon Cable Assembly                   |
| 242857                               | 1    | Seal for Switches                       |
| 243400                               | 1    | Sensor & O-ring                         |
| 350264                               | 1    | Straight Sensor Body                    |
| 350265                               | 1    | 90° Sensor Body                         |
| <b>Stainless Steel Service Parts</b> |      |   |
| 237747                               | 1    | 90° S.S. Sensor Body                    |
| 237748                               | 1    | Straight S.S. Sensor Body               |
| 244041                               | 1    | S.S. Sensor and O-ring                  |

## SPECIFICATIONS

|   |  |
|---|--|
| <b>Input Voltage</b> .....                | 120 VAC 50/60 Hz<br>230 VAC 50/60 Hz<br>24 VDC   |
| <b>Current Consumption</b> .....          | 200 MA at 120 VAC (less alarm load)<br>105 MA at 230 VAC (less alarm load)<br>800 MA at 24 VDC (less alarm load) |
| <b>External Alarm Load</b> .....          | 360VA Pilot Duty Rating at 120/230 VAC<br>5 amps at 24 VDC   |
| <b>Ampacity for Scan Switch</b>           |  |
| <b>connected to Terminal Strip B...</b>   | 8 MA at 15 VDC   |
| <b>Maximum Sensor Current</b> .....       | 45 MA at 15 VDC  |
| <b>Scan Input at Terminal A</b> .....     | 120/230 VAC at 10 MA   |
| <b>Enclosure</b> .....                    | Nema 12 enclosure  |
| <b>Net Weight</b> .....                   | 10 lbs   |
| <b>Controller Temperature Range</b> ..... | 10° F to 130° F (LCD limited)  |
| <b>Lubricant Temperature Range</b>        |  |
| <b>for Sensors</b> .....                  | 32° F to 145° F  |
| <b>Minimum Amount of Lubricant</b>        |  |
| <b>Delivery to Sensor</b> .....           | .004 cubic inches (32° F to 125° F)<br>.008 cubic inches (125° F to 145° F)                                      |
| <b>Minimum Amount of Time</b>             |  |
| <b>between Lube Events</b> .....          | 30 seconds   |
| <b>Timing Accuracy</b> .....              | 01% (crystal controlled)   |

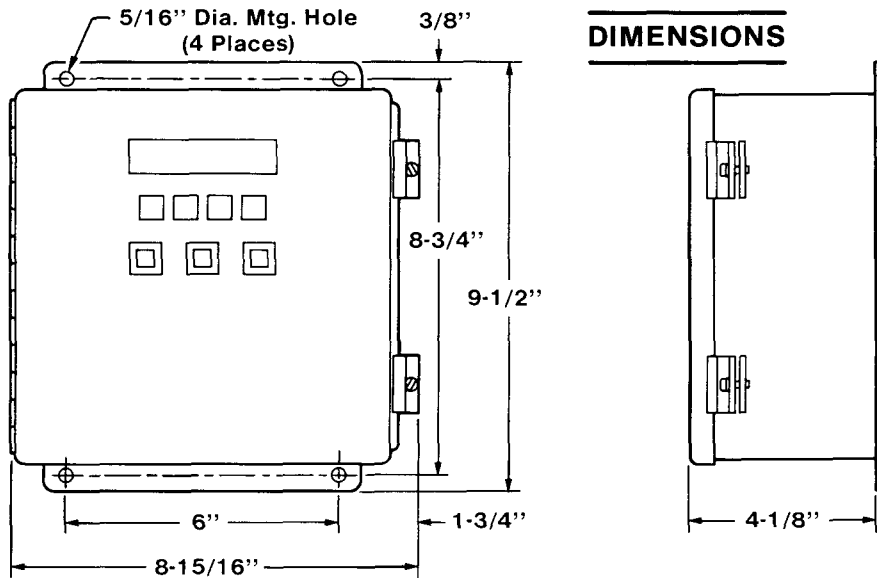

## SYSTEM ACCESSORIES

| Part                                      | Qty.    | Description  |
|---|---------|--|
| 84602                                     | 1       | Junction Box Assembly (Mounting Dimensions 10 75" x 6")                    |
| 243000                                    | 1       | Straight Sensor Assembly (body & sensor)                                   |
| 243010                                    | 10 ft.  | 2 Conductor Sensor Wire w/connector, terminal & boot                       |
| 243020                                    | 20 ft.  | 2 Conductor Sensor Wire w/connector, terminal & boot                       |
| 243030                                    | 30 ft.  | 2 Conductor Sensor Wire w/connector, terminal & boot                       |
| 243090                                    | 1       | 90° Sensor Assembly (body & sensor)  |
| 243100                                    | 100 ft. | 2 Conductor Sensor Wire  |
| 243500                                    | 1       | Terminal Kit (boot, connector & terminals)                                 |
| 243600                                    | 1       | Hand Tool to crimp terminals   |
| 244020                                    | 20 ft.  | 20 Conductor Control Wire  |
| 244100                                    | 100 ft. | 20 Conductor Control Wire  |
| <b>Stainless Steel System Accessories</b> |         |  |
| 244040                                    | 1       | Straight S.S. Sensor Assembly (body & sensor w/male water-tight connector) |
| 244090                                    | 1       | 90° S.S. Sensor Assembly (body & sensor w/male water-tight connector)      |
| 244205                                    | 100 ft. | Cable for S.S. Sensor w/female water-tight connector on one end            |

**NOTE:** Stainless Steel Sensors and Bodies are made from 316 material

### RETAIN THIS INFORMATION FOR FUTURE REFERENCE

When ordering replacement parts, list: Part Number, Description, Model Number and Series Letter.  
LINCOLN provides a Distributor Network that stocks equipment and replacement parts.