

**Model 84944 Series "C"  
Model 85461 Series "A"  
Hydraulically Operated Pump**

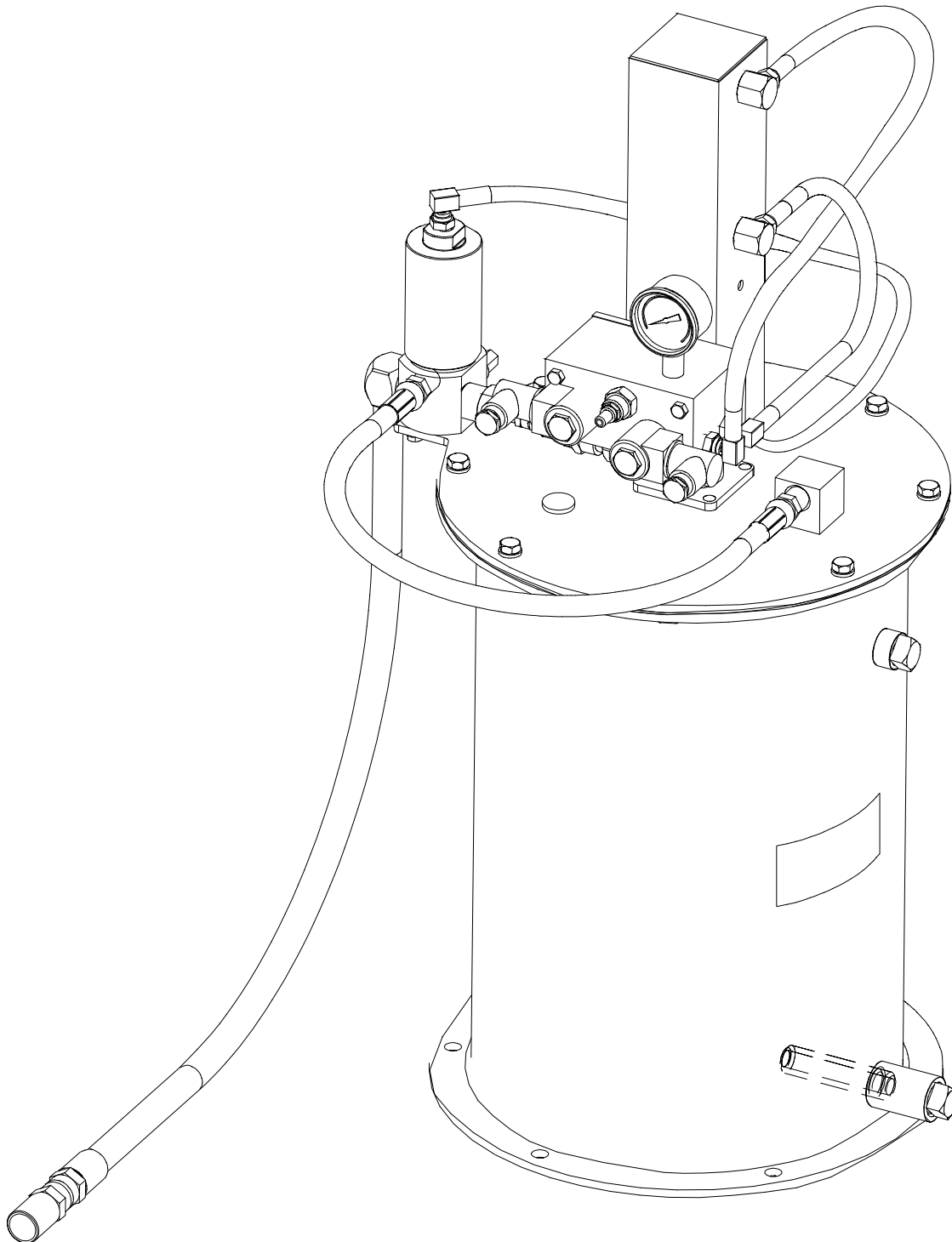

## TABLE OF CONTENTS

	Page
Safety.....	2
Specifications.....	2
Description.....	2
Pump Operation.....	2
Installing the Pump.....	2
Optional Devices.....	3
Putting Pump into Operation.....	3
Maintenance and Repair.....	3
Dimensions.....	6
Repair Parts List.....	7
Troubleshooting.....	8

## SAFETY

Read and carefully observe these operating instructions before unpacking and operating the pump! The pump must be operated, maintained and repaired exclusively by persons familiar with the operating instructions. Local safety regulations regarding installation, operation and maintenance must be followed.

Operate this pump only after safety instructions and this service manual are fully understood.



This symbol identifies the potential for a hazardous situation. If this warning is not followed, a serious injury could occur.

Please refer to the following service page for the Model 84961 pump for all other safety considerations:

84961 Hydraulic Pump - Section C8, Page 240 Series  
85530 Controller - Section C8, Page 259 Series

## PRODUCT SPECIFICATIONS

Pump Ratio:	<b>16:1</b>
Input Pressure	<b>300 to 3500 PSI© (21 to 241 bar)©</b>
Input Flow	<b>1.0 GPM (3.8 l/min)</b>
Maximum Hydraulic Temp.	<b>210° F (99° C)</b>
Output Pressure	<b>3500 PSI Maximum (241 bar)</b>
Output Flow	<b>11 in<sup>3</sup>/min (180 cc/min)</b>
Ambient Temperature	<b>-40° to 135° F (-40° to 57° C)</b>
Seals	
Pump	<b>Polyurethane</b>
Motor	<b>Buna-N</b>
Vent Valve	<b>Viton</b>
Hydraulic Filtration Required	<b>10 Micron</b>
Container Capacity	<b>60 lbs.</b>
Weight (84944)	<b>68 lbs. (31 kg)</b>
(85461)	<b>78 lbs. (35 kg)</b>

**IMPORTANT NOTE:** Maximum allowable hydraulic return line pressure **NOT TO EXCEED** 30 PSI (2.07 bar) for proper venting of SL-1 injectors (45 psi ( 3.1 bar) for SL-11).

## DESCRIPTION

### General Description

The Models 84944 and 85461 are pumping systems designed to operate centralized lubrication systems which utilize single line parallel grease metering components. The pump is double acting, dispensing lubricant on both the UP and DOWN strokes. These units are designed to be used with SL-1, SL-11, SL-32, and SL-33 series injectors or a combination of these. These units are designed for off road equipment which utilizes 24 VDC power sources. These units can be used in conjunction with the Models 85530 or 84015 Controller and Model 249605 Cycle Timer. The difference between the two models is that the 85461 is equipped with a follower and a low level indicator.

### Appropriate Use

- The pumps on these units are exclusively designed to pump and dispense lubricants using hydraulic fluid pressure only.
- The maximum specification ratings should not be exceeded.
- Any other use not in accordance with instructions will result in loss of claims for warranty and liability.

## PUMP OPERATION

### Operation with Model 85530 System Controller

When Model 85530 times out, it will initiate a lube cycle. The hydraulic solenoid is energized to deliver hydraulic fluid to the pump and to the vent valve. Pump begins dispensing lubricant through injectors to the bearings.

When all bearings have received lubricant, pressure rises in the system to actuate the pressure switch. When pressure switch actuates, the control is reset to de-energize the solenoid valve cutting off pressure to the pump and vent valve. Pump stops, pressure vents and pressure switch de-actuates. Control begins timing toward next lube event.

## INSTALLING THE PUMP

Place the unit in the approximate location making sure that grease and hydraulic connections are accessible. Mark center locations of the six holes at the bottom of the reservoir. Then drill six 1/2" holes. The use of 7/16" bolts will offer some flexibility in securing the reservoir to the equipment.

Lubricant outlet of pump should be connected to system with suitable hose capable of 3,500 PSI (241 bar) working pressure.

Hydraulic supply line connection should be made with at least 1/4" I. D. hose rated for maximum system hydraulic fluid pressure.

© indicates change

## OPTIONAL DEVICES

### Low Level Kit

- Model 249608 Low Level Kit can be installed whenever higher viscosity greases or lower temperatures are encountered and when an external indicator of lubricant level is desired. The kit is composed of a follower with wiper attached to a level indicator gage located on the cover of the reservoir.

## PUTTING PUMP INTO OPERATION

### Filling Reservoir

- To bulk fill the reservoir, remove the lower and upper pipe plugs from the side of the reservoir. Attach the appropriate bulk-filling pump to the lower inlet (3/4 NPT). Fill reservoir until grease appears at the top 1/2 NPT high level port. Remove the bulk-filling pump. Replace both pipe plugs.
- To fill the reservoir using a five-gallon pail of lubricant, first remove the six bolts that secure the lid. Remove the entire assembly of lid, pump and vent valve. Using pipe wrench or vice grips, remove the filler nipple extension attached inside the reservoir at the 3/4 NPT inlet nipple. Insert opened pail of lubricant and reattach lid and pump assembly.

**Note:** If pail lubrication is to be used, then the optional wing screws (60) should be used in place of the hex bolt (35).



When filling the reservoir, caution should be used as extreme pressure can cause damage to the reservoir or serious personal injury.

## MAINTENANCE & REPAIR

### General Maintenance

- Good housekeeping will go a long way in keeping a lubrication system running without problems for many years of use.
- Keep area around pump clean. Clean off filling area prior to filling reservoir. Clean area around filler after filling as lubricants will attract dirt.
- Keep lubricants clean and free of dirt and debris.
- When replacing grease pails be especially careful to prevent any foreign matter from entering the grease pail or contaminating the grease, as it adheres to the pump.

### In Case of Trouble

#### (See Trouble Shooting Chart Page 7)

- Use the **Trouble Shooting Chart** to determine where to look if problems occur.
- See the sections below for replacement and repair of specific areas of the check valve, vent valve or safety unloader valve.

- Each part is identified with a number keyed to the matching part on the illustrated views.
- General recommendations of tools required are also specified in each step.
- Pay particular attention to the **Warning** statements to prevent personal injury and possible damage to pump components.

### Outlet Check Service (See Illustration Page 5)

1. Turn off and disconnect the hydraulic supply to the pump assembly.
2. Standard tools required are a bench mounted vice, a set of open end wrenches ranging from 7/16 to 1-1/2, a large 24" adjustable wrench and a smaller 10" adjustable wrench.
3. Remove bolts and lockwashers (44 & 45).
4. Loosen union (12) and set vent valve assembly to the side.
5. Remove entire outlet check assembly (6) by loosening adapter (8) from pump outlet.
6. Remove adapter (8) from bushing (20).
7. Remove outlet connector (11) from bushing (20).
8. Remove ball check seat (21) from outlet connector (24).
9. Inspect all check components (19, 20, 21, 23) for presence of foreign material, scoring and or other damage, which may cause internal leakage.
10. If foreign material is present, clean components and reassemble, making sure to replace gaskets (18 & 22). Reverse the above procedure to reassemble. Torque check assembly to 100 ft.-lbs.
11. If check components appear to be scored or damaged replace all components (19, 20, 21, 23) and gaskets (18 & 22) with new ones. Reverse the above procedure to reassemble. Torque check assembly to 100 ft.-lbs.

### Vent Valve Service (See Illustration Page 5)

1. Turn off and disconnect the hydraulic supply to the pump assembly.
2. Standard tools required are a bench mounted vice, a set of open end wrenches ranging from 7/16 to 1-1/2, a large 24" adjustable wrench and a smaller 10" adjustable wrench.
3. Remove delivery hose (15). Remove vent hoses (42 & 46).
4. Remove bolts and lockwashers (44 & 45).
5. Loosen union (12) and remove vent valve.
6. Hold base of vent valve in vice to remove nipple (11) and elbow (13). Turn vent valve in vice so that vice jaws are gripping flats machined on base of vent valve.
7. Remove cylinder (25). Remove piston and packing assembly (26) from cylinder. If leakage was evident from side of cylinder then replace packing.
8. Remove packing assembly (28). If grease leakage is evident from side of cylinder, then replace packing assembly.
9. Inspect needle (27) and valve seat (29). If foreign matter is lodged and is keeping the needle from sealing in valve seat, clean and inspect for damage. If seat appears damaged by nicks, grooves or scouring it should be replaced. Remove valve seat (29) from valve body (31) by placing a 3/4" open end wrench onto the flats and loosening the seat. The use of an adjustable wrench over

the open end wrench may be necessary due to the accessibility of the seat.

10. Replace the valve seat (29) if damaged. Also be sure to remove and replace the gasket (30) below the seat.
11. Reassembly is the reverse of the above procedure. Needle (27) and cylinder (25) inside diameter should be coated with oil or grease to assist in assembly.
12. Upon reassembly tighten valve seat (29) into body (31) using 25 ft.-lbs. Tighten air cylinder (25) onto valve body (31) using 100 ft.-lbs.

### **Follower (see Illustration Page 5)**

If follower wiper appears to be damaged or does not wipe the sides of the container effectively service may be necessary.

1. Disconnect hydraulic supply from pump.
2. Remove the eight bolts (35) and lock washers (36) which attach the cover to the reservoir.
3. Lift the entire pump, vent valve and cover assembly out of the reservoir.
4. Unscrew the low level indicator (55) from the follower plate (56).
5. Now remove the entire follower assembly from the pump tube. After removing the follower assembly from the pump tube wipe off the excess grease which will allow clean access to the eight bolts that must be removed.
6. Loosen and remove the eight nuts (5) on top of the follower.
7. Remove the follower weight (56) and the wiper (1). Replace the wiper with a new one.
8. Reassemble in the reverse of the above procedure making sure that the long carriage bolts are staggered with the small ones and that they extend below the follower per the dimension shown.

### **Low Level Indicator (see Illustration Page 6)**

If the indicator pin appears to drop prematurely or water is noticeable on top of the follower then the indicator seal (54) may be damaged.

1. Remove the eight bolts (35) and lockwashers (36) which hold the cover on to the reservoir.
2. Inspect the reservoir seal (47) for damage. If damage is apparent then replace the seal.
3. Remove the entire pump, vent valve and follower assembly from the reservoir.
4. Remove the retaining ring (52) from the indicator rod assembly (55).
5. Hold the indicator plug (57) with a wrench while removing the indicator nut (53).
6. Remove and replace the O-ring (54).
7. Reassemble in the reverse of the above procedure. Torque the indicator nut (53) to 20 ft.-lbs.

### **Safety Unloader Valve (see Illustration Page 6)**

The Safety Unloader (10) is set to open at 3,750 to 4,250 PSI lubricant pressure. If pressure Switch fails to operate and shut off hydraulic supply to pump, the Safety Unloader will open at approximately 4,000 PSI to relieve lubricant supply line pressure.

Safety unloader valve (10) is not serviceable and should be replaced if malfunction is apparent. Upon reassembly, tighten to 10 ft.-lbs.

### **Bare Pump Assembly (See Illustration Page 5)**

Please refer to the service page included for the bare pump assembly (43).

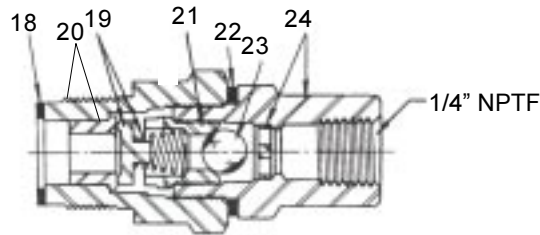

**Outlet Check Assembly (6)**

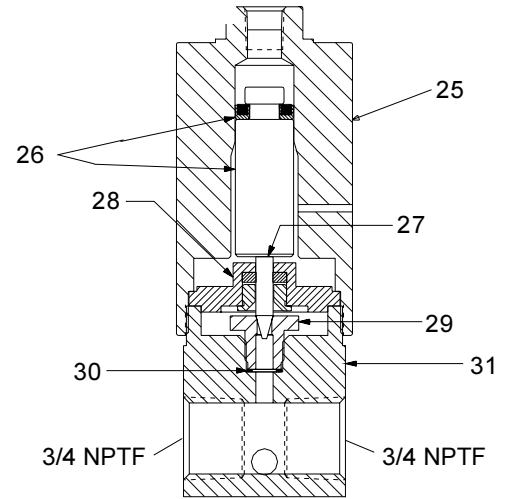

**Vent Valve Assembly (9)**

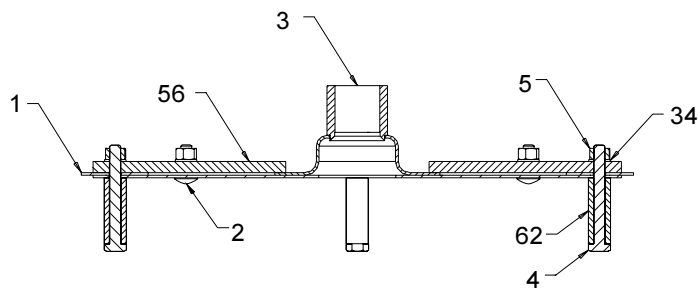

**Follower Assembly (41)**

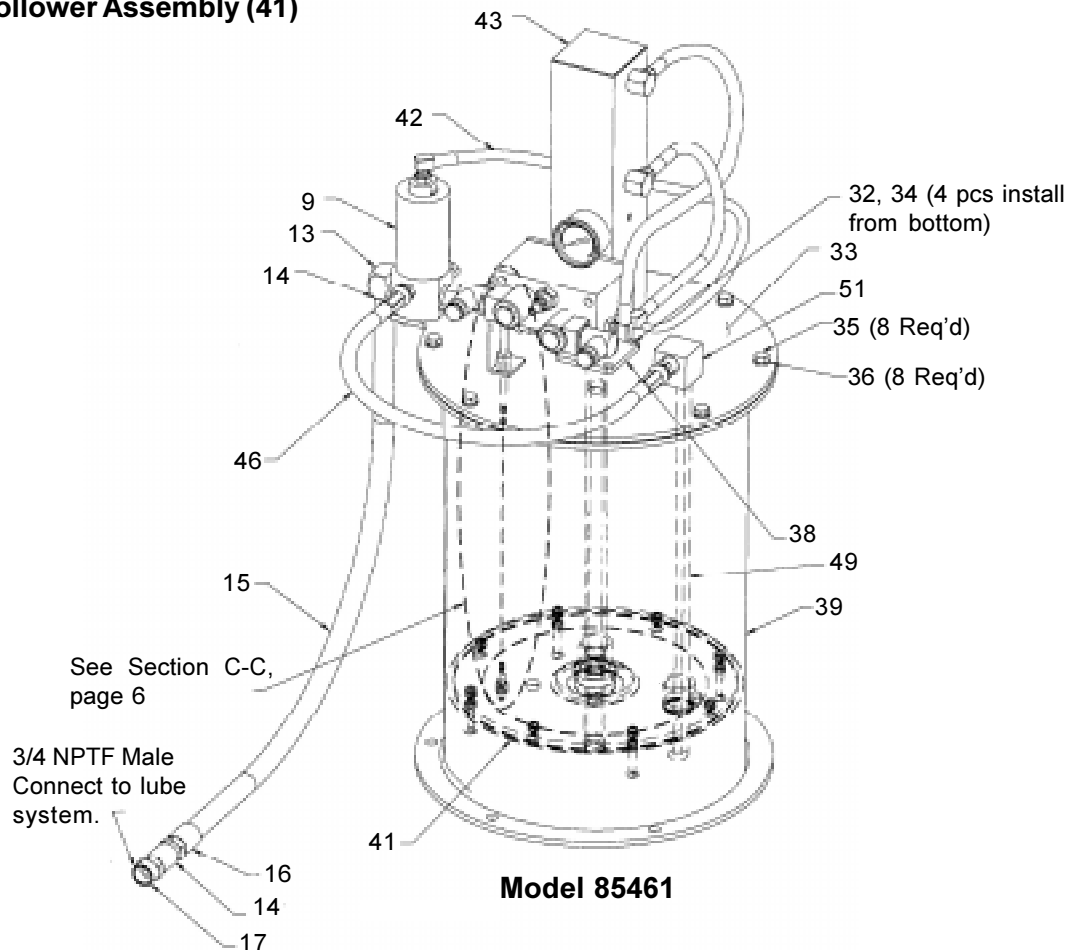

**Model 85461**

# CENTRO-MATIC® PUMP, MODELS 84944 & 85461

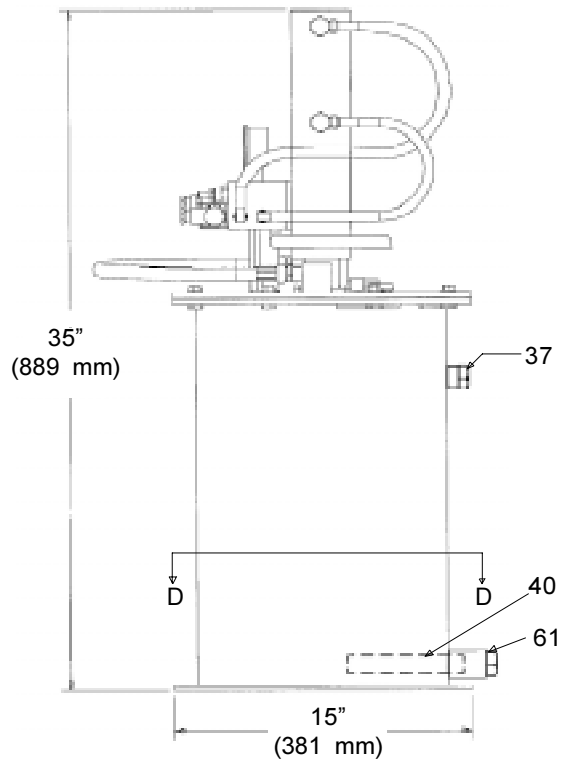
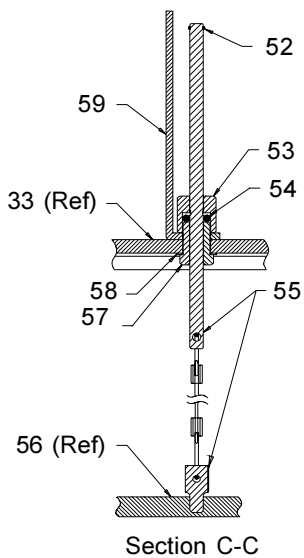
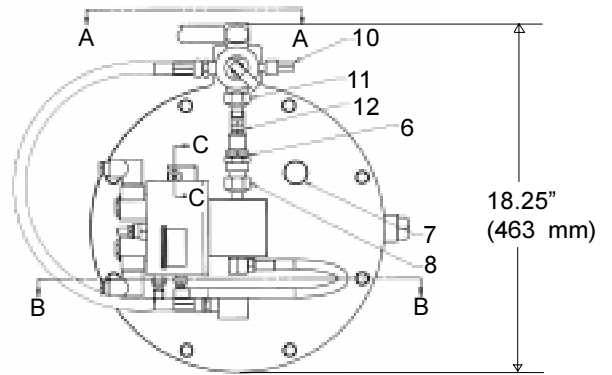
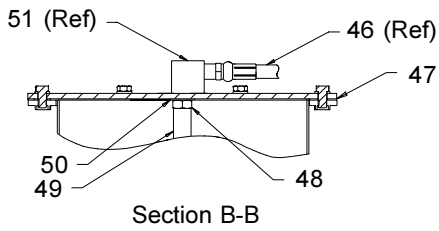
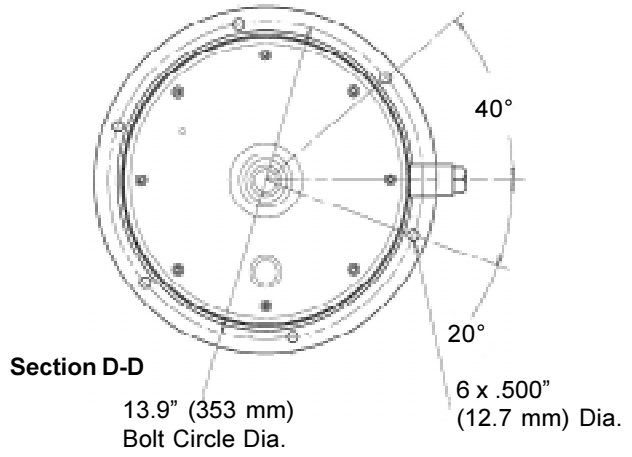
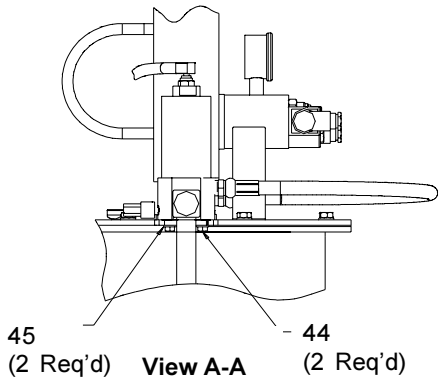

## SERVICE PARTS

Item No.	Qty.	Description	Model 85461/84944
1	1	Wiper (Nitrile)	*249331
2	4	Carriage Bolt (Short)	249332
3	1	Follower Guide Plate	249333
4	4	Bolt - Long	50084
5	8	Nut	51304
6	1	Outlet Check Ass'y	81938
7	1	Vent Fitting	249354
8	1	Adapter	12213
9	1	Vent Valve Assembly	84980
10	1	Safety Unloader Ass'y	*90942
11	1	Nipple	14727
12	1	Union	66645
13	1	Elbow	10160
14	2	Nipple	11197
15	1	Delivery Hose	236607
16	1	Adapter Union	66883
17	1	Bushing	12018
18	1	Gasket	*31029
19	1	Pump Check Disc Ass'y	+*80206
20	1	Outlet Check Bushing	+*90204
21	1	Ball Check Seat	*10313
22	1	Gasket	*31001
23	1	Steel ball (3/8" Dia.)	*66001
24	1	Outlet Connector	+90860
25	1	Cylinder	241807
26	1	Piston Ass'y	244673
27	1	Needle	*14722
28	1	Viton Packing Ass'y	+*239330
29	1	Valve Seat	*14723
30	1	Check Seat Gasket	*31047
31	1	Valve Body	239336

Item No.	Qty.	Description	Model 85461/84944
32	4	Screw	50169
33	1	Cover	241085
34	12	Lock Washer	66186
35	8	Bolt	50015
36	8	Lockwasher	66220
37	1	Pipe Plug	67117
38	1	Gasket	33152
39	1	Container Ass'y	242765
40	1	Extension Tube	249356
41	1	Follower Ass'y	249330
42	1	Hose Ass'y	241963
43	1	Hydraulic Pump	84961
44	2	Bolt	50016
45	2	Lockwasher	66246
46	1	Volume Hose	236874
47	1	Gasket	*249355
48	1	Nut	12538
49	1	Vent Pipe	67420
50	1	Gasket	*31010
51	1	Elbow	249533
52	1	Retaining Ring	*68888
53	1	Indicator Nut	16352
54	1	O-Ring	*249532
55	1	Cable Assembly	249762
56	1	Follower Weight	249334
57	1	Indicator Plug	249357
58	1	Washer	48548
59	1	Indicator Bracket	361020
60	8	Wing Bolts - not shown	252727
61	1	Pipe Plug	67224
62	4	Spacer	249833

\* Suggested service replacement components.  
 + Sold as an assembly. Individual parts not available.

## MODEL 85461 & 84944 TROUBLESHOOTING

Condition	Possible Cause	Corrective Action
Pump does not operate.	No hydraulic pressure to pump.	Turn on or connect hydraulic supply to pump.
	Hydraulic motor or pump tube malfunction.	Refer to pump service page.
Pump runs excessively.	Pump tube malfunction.	Refer to pump service page.
	Outlet check damage or contamination.	Repair check or remove contamination.
	Vent valve damage or contamination.	Repair vent valve or remove contamination.
	System component leaking.	Repair leaks.
	Injector bypassing.	Repair injectors.
Lubricant leaking from weep hole of pump outlet casting.	Pump tube malfunction.	Refer to pump service page.
Lubricant leaking from safety unloader valve.	Pressure of system set too high.	Adjust pressure switch setting.
	Safety unloader damaged or contaminated.	Replace safety unloader.
Hydraulic fluid leaking from weep hole in vent valve.	Vent valve piston seal damaged.	Replace piston and seal assembly.
Lubricant leaking from weep hole in vent valve.	Vent valve lubricant seal damaged.	Replace lubricant seal.

Lincoln Industrial  
 One Lincoln Way  
 St. Louis, MO 63120-1578  
 (+1) 314 679 4200  
[www.lincolnindustrial.com](http://www.lincolnindustrial.com)

Lincoln GmbH  
 69190 Walldorf  
 Heinrich-Hertz Strasse 2-8  
 (+49) 6227 33-0

Lincoln Industrial  
 25 International Business Park  
 #01-68 German Centre  
 Singapore 609916  
 (+65) 562-7960