

**Air Operated Single Stroke Pumps with  
Controls, Spring Return**

**Models for Fluids: 85438, 85439, 85440, 85441**

**Models for Grease: 85442, 85443, 85444, 85445**

**Series "A"**

**CE** (230 VAC Models only)©

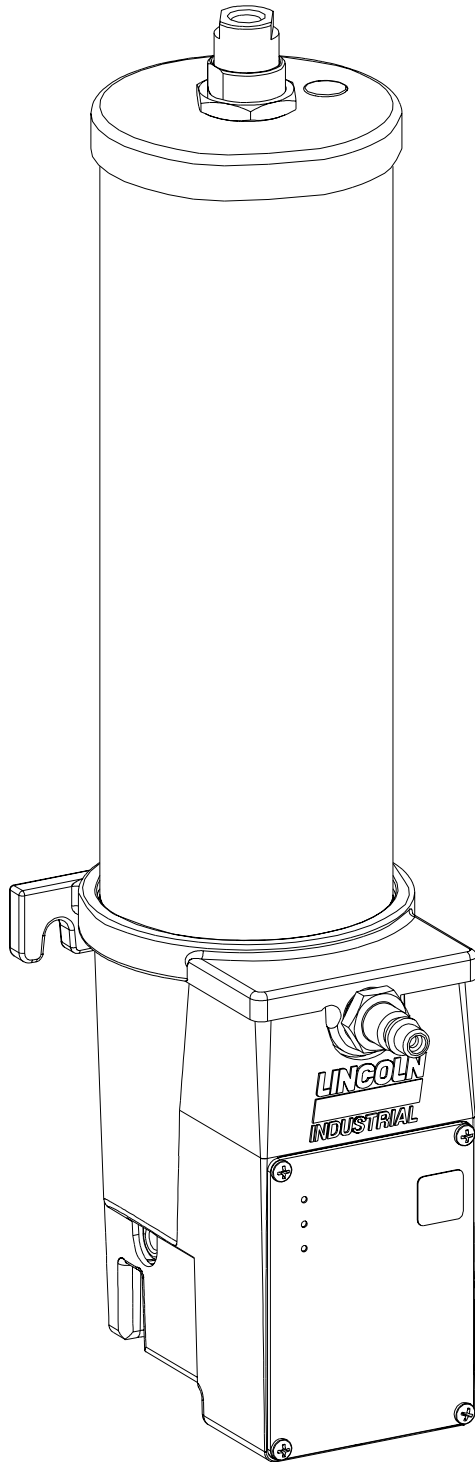

© Indicates change

## Table of Contents

	Page
Safety .....	2
Description.....	2
Control Operation.....	3
Pump Operation.....	4
Installing the Pump.....	4
Optional Devices.....	4
Putting Pump into Operation.....	5
Setting the Timer/Controller.....	5
Maintenance and Repair.....	5
Dimensions.....	8
Repair Parts List.....	11
Trouble Shooting.....	12



### Warning!

This symbol identifies the potential for a **hazardous** situation. If this warning is not followed, a serious injury could occur.

## Description

### General Description

The pumps are air operated single stroke, spring return, positive displacement units and should be used to deliver lubricant under pressure to the metering devices (injectors). A three way solenoid valve to control air input and an adjustable timer to control the lubrication cycle are integrated into the pump body. The pump can be used to deliver oil or grease depending upon the model per product specification below. Pump models 85442, 85443, 85444 & 85445 for grease applications have a special high volume refill fitting. All pump models have a control panel with indicator lights. The pumps should be installed upright for proper operation.

## Safety

Read and carefully observe these operating instructions before unpacking and operating the pump! The pump must be operated, maintained and repaired exclusively by persons familiar with the operating instructions. Local safety regulations regarding installation, operation and maintenance must be followed.

Operate this pump only after safety instructions and this service manual are fully understood.



### Electrical Warning!

This symbol identifies the potential for a **hazardous electrical** situation. If this warning is not followed, a serious injury could occur.

### Appropriate Use

- All models are exclusively designed for use in Centralized Lubrication Systems delivering lubricants.
- The maximum ratings given should not be exceeded.
- Any other use not in accordance with the instructions will result in loss of claims for warranty and liability.

## Product Specification

Model	Pump	Ratio	Control Voltage 50/60 Hz	Current Consumption	Electrical Enclosure Rating	Output Per Stroke Cu. In. (cc)	Reservoir Capacity	
							Pint (Liter)	Cu. In. (cc)
85438	Fluid	20:1	120 VAC	8.5 VA	NEMA 12	.450 (7.4)	1 1/4 (.6)	36 (600)
85439			240 VAC					
85440			120 VAC				4 1/4 (2.0)	123 (2000)
85441			240 VAC					
							Lb. (kg)	Cu. In. (cc)
85442	Grease	20:1	120 VAC	8.5 VA	NEMA 12	.450 (7.4)	1 (.45)	30 (492)
85443			240 VAC					
85444			120 VAC				4 (1.8)	120 (1967)
85445			240 VAC					

Model	Air Inlet	Lubricant Outlet	Air Pressure		Air Consumption @100 P.S.I. (6.8 bar)	Operating Temp. Range
			Min.	Max.		
85438	1/8"	1/4"	20	150	.15 SCF	-10° F
85439	NPTF	NPTF	PSIG	PSIG	(4.0 l(n))	(-23° C)
85440	(Female)	(Female)	(1.4 Bar)	(10.2 bar)	Per stroke	+150° F
85441						(+65° C)
85442	1/8"	1/4"	20	150	.15 SCF	-10° F
85443	NPTF	NPTF	PSIG	PSIG	(4.0 l(n))	(-23° C)
85444	(Female)	(Female)	(1.4 bar)	(10.2 bar)	Per stroke	+150°
85445						(+65° F)

## Control Operation (See Illustration 1 for operating controls description.)

### Timer Mode

- When the **Mode Switch** is set to **Timer** the pump will deliver lubricant at timed intervals as set on the rotary switch, and **Units** switch setting.
- The rotary switch on the timer/controller board sets the time between lube events (**Off** time).
- A low-level switch may also be added to indicate a low lubricant level in the reservoir.
- When a low level condition is detected the **Alarm L.E.D.** will light, alarm contacts connected to terminals 5 & 6 will close, and the lubrication sequence will stop.
- The pump assembly will remain in the alarm mode until the reservoir is refilled and the unit is reset by turning the power off and on or the **Manual Lube** button is pressed.
- Pressing the **Manual Lube** button will always initiate a lube event.

### Controller Mode

- When the **Mode Switch** is set to **Controller** the pump will operate as in the **Timer Mode**, with pressure monitoring capabilities added.
- A pressure switch must be installed in the supply line.
- The pressure switch will reset the controller when set pressure is detected.
- The unit will initiate an alarm when the pump fails to develop sufficient pressure to actuate the pressure switch within the "**On Time**" setting.
- Either a low-level condition or a low-pressure condition will cause the unit to go into alarm.
- When an alarm condition is detected the **Alarm L.E.D.** will light, alarm contacts connected to terminals 5 & 6 will close, and the lubrication sequence will stop.
- The pump assembly will remain in the alarm mode until the cause of the fault is corrected and the unit is reset by turning the power off and on or the **Manual Lube** button is pressed.
- Pressing the **Manual Lube** button will always initiate a lube event.

Illustration 1

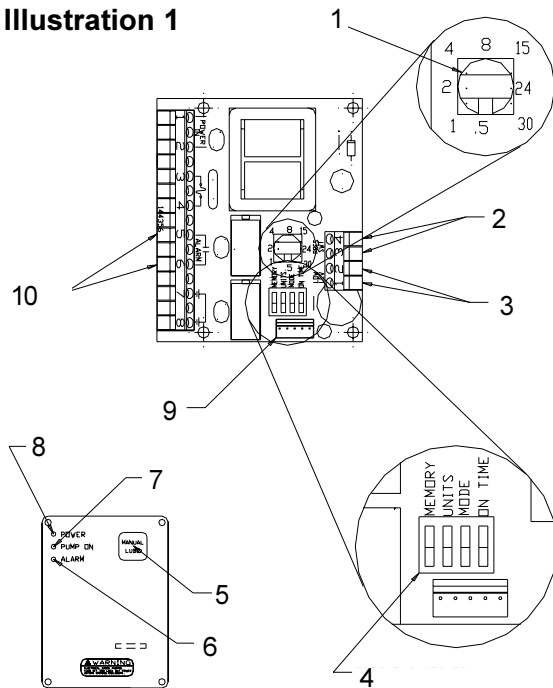

### Keypad Controls

Illustration 1

1. Rotary Switch - Cycle (off)  
Time setting - point slot to desired time printed on board.
2. Pressure Switch Terminals
3. Low Level Switch Terminals
4. Toggle Switches:  
Memory\* - dn = off, up = on,  
Units - dn = minutes,  
up = hours,
5. Manual Lube Push Button
6. "Alarm" L.E.D. Indicator, Red
7. "Pump On" L.E.D. indicator, green
8. "Power" L.E.D. indicator, green
9. Keypad Ribbon Connector
10. Alarm Contact Terminals

Mode - dn = controller,  
up = timer,  
On Time - dn = 10  
sec., up = 30 sec

Illustration 2

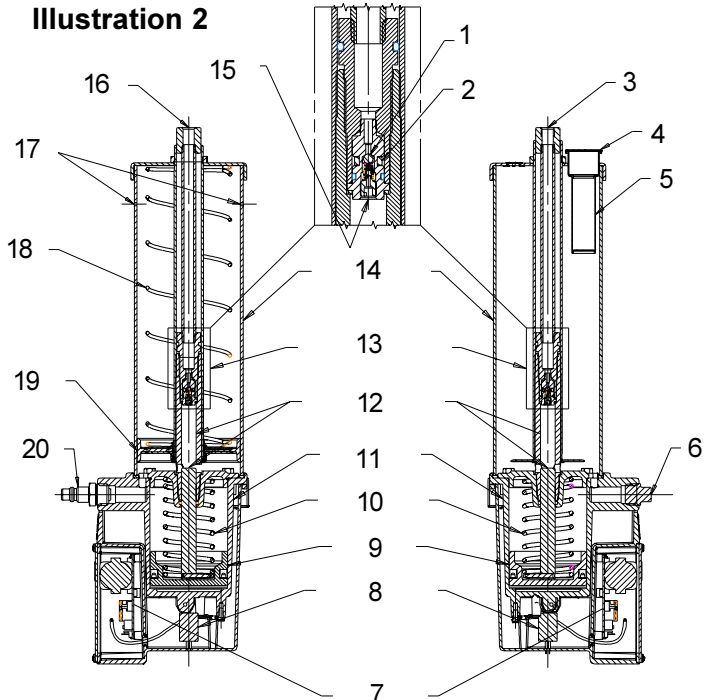
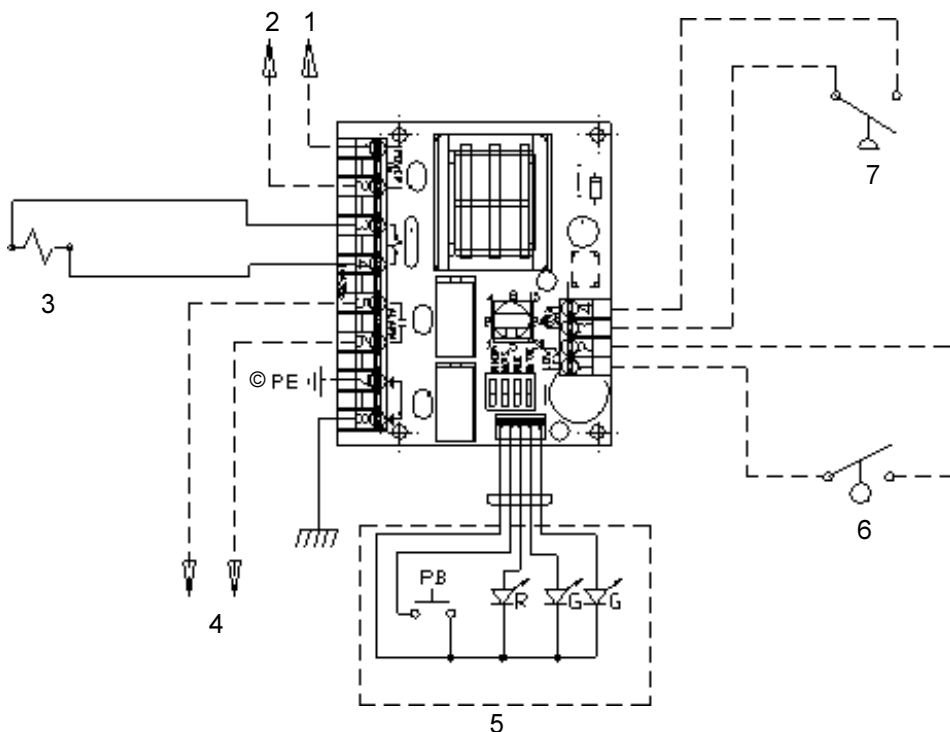

Illustration 2

1. Ball Check
2. Check Packing
3. Lube Outlet 1/4" NPTF
4. Filler Cap
5. Lubricant Strainer
6. Drain Plug
7. Timer Board
8. Solenoid Valve
9. Air Piston
10. Piston Spring
11. Air Cylinder
12. Bushing & Plunger
13. Check & Valve Ass'y
14. Reservoir Tube
15. Ball Stop Adjustment
16. Lube Outlet 1/4" NPTF
17. Air Vent Both Sides
18. Follower Spring
19. Follower Ass'y
20. Filler Fitting

\***Memory: On/Off**, When set to **On**, the timer/controller will "remember" where it is in the time sequence for up to 3 hours when power is removed from the board. This function is used to eliminate over lubrication caused by frequent power up/down sequences, which may be necessary in the function or set-up of the machine. When set to **Off**, the unit will initiate a lube cycle each time power is applied to the unit.

## Wiring Diagram



© Indicates change

## Wiring Diagram

1. L1
2. L2
3. Air Solenoid Valve.
4. Optional Alarm wired by customer.
5. Keypad with indicator lights and manual lube push button.
6. Optional Low Level Switch wired by customer.
7. Optional Pressure Switch wired by customer.

## Pump Operation (see Illustration 2)

- When a lube cycle is initiated by the timer/controller, the 3-way solenoid valve is energized allowing compressed air to enter the bottom of the air cylinder, which moves the piston with the plunger upward.
- When the pump "On" time expires, the solenoid valve is de-energized cutting off the flow of air to the air cylinder, and relieving the air pressure in the cylinder. The piston spring moves the piston and plunger downward. In its extreme down position, the plunger has retracted below the bushing port, permitting lubricant to flow into the bushing cavity.
- Lubricant pressure from the supply line is allowed to "vent" back through the ball check, into the bushing cavity thus allowing the injectors to reset.

## Installing the Pump (See Illustrations 4 & 5)

- Pump must be mounted in a vertical position.
- Mount to an even, stable, & solid surface.
- Mount with 3/8" [10mm] screws. (2 mounting slots provided on back of air cylinder.)
- Mount in area away from dust, dirt and moisture. (Pumps are not designed for wash down environments or for outside weather conditions.)
- Allow sufficient space for servicing, filling, and operating the pump.
- Mount in an area where the pump can be observed for monitoring lubricant level and pump operation, unless auxiliary-monitoring equipment is installed.

## Electrical Connections (See Wiring Diagram)

- A terminal wiring diagram is located on the back side of the keypad assembly.
- One 1/2" conduit opening is provided on the bottom side of the timer/controller enclosure. An additional 1/2" conduit knock out is located adjacent to the opening.
- All wiring and fusing is to be in accordance with the National Electric Code regulations of the regulating agency where the unit is to be installed.

## Optional Devices

### Pressure Switch

- Model 69630 pressure switch should be installed in the supply line to the injectors.
- The pressure switch must be wired "normally open" with connections to low voltage terminals 3 & 4. See Wiring Diagram.
- The mode switch on the timer/controller board must be set for **Controller** operation for the pressure switch to be effective.
- The pressure switch should be adjusted to a pressure high enough to insure proper system operation.
- Switch ampacity: 1 MA at 5 VDC.

## Low Level Switch

- Use low level switch 83696 with models 85440 and 85441. (A low level switch is not available for models 85438 and 85439.)
- Use low level switch 83671 with models 85444 and 85445. (A low level switch is not available for models 85442 and 85443.)
- The low level switch is to be wired "Normally Open" with connections to low voltage terminals 1 & 2. See Wiring Diagram.
- When the low level switch closes, an alarm will be initiated.
- The low level option can be used in either the **Timer** or **Controller** mode.
- Switch Ampacity: 1 MA at 5 VDC.

## Alarm Contacts

- Relay contacts are provided on the timer/controller board for connecting an external alarm device. These contacts may be used for a light, horn, or another warning device, or they may be used for machine shut down in the event of a lube failure.
- The alarm is to be connected to terminals 5 & 6, see Wiring Diagram.
- The contacts will close on a fault condition.
- Contact ratings: 2 Amps inductive load at 30 VDC, 120 VAC and 250 VAC. **Do not exceed ratings.**

## Putting Pump Into Operation

### Filling Fluid Reservoirs

- The transparent lubricant reservoir is filled with oil through the filler cap at the top of the reservoir.
- The lubricant strainer should be removed from the filler cap and cleaned periodically before filling.

### Filling Grease Reservoirs

- Use Manual Filler Pump 81834 to fill the reservoir through the filler fitting in the pump body.
- Attach the filler coupler on the delivery hose to the filler fitting. Stroke the filler pump handle until lubricant seepage is noted at the air vent holes in the reservoir (see illus. 2). Note that the lower edge of the follower must rise above the vent holes to expel entrapped air from the lubricant.



**Warning!** When filling the reservoir, caution should be used as extreme pressure can cause damage to the reservoir and follower assembly.

### Priming Supply & Feed Lines

- Prime lines with lubricant to expel air for the proper operation of the pump and system.
- Manual lube button can be used to prime the supply lines.

## Setting The Timer/Controller



**Warning!** Electrical shock hazard. Disconnect and lock out all power to the pump unit before removing the keypad of the timer compartment.

- Remove four Phillips head screws holding the keypad to the front of the timer compartment.
- Set the toggle switch settings as required for **Memory, Units, Mode of operation, & On Time**. See Illustration 1.
- Set the rotary switch for the required pump cycle times (off time)

by pointing the indicator or slot to the time settings printed on the circuit board around the switch.

- Install keypad by carefully folding the ribbon cable back across the timer board, taking care not to pinch the cable between the keypad and front face of the enclosure.
- Secure with four Phillips head screws.

## Maintenance & Repair

### General Maintenance

- Good housekeeping will go a long way in keeping a lubrication system running without problems for many years of use.
- Keep area around pump clean. Clean off filling area prior to filling reservoir. Clean area around filler after filling. Lubricants will attract dirt like a magnet.
- Keep lubricants clean and free of dirt and debris. Use filtered lubricants to refill reservoirs.

### In Case of Trouble

#### (See Trouble Shooting Chart Page 12)

- Problem areas can be broken down into 3 areas: electrical, pneumatic, and hydraulic.
- Use the **Trouble Shooting Charts** to determine where to look if problems occur.
- See the sections below for replacement and repair of specific areas of the pump and control.
- Each part is identified with a number keyed to the matching part on the exploded illustrations.
- When required, tool sizes are also specified in each step.
- Pay particular attention to the **Warning** and **Caution** statements to prevent personal injury and possible damage to pump components.
- Do not use solvents on acrylic reservoir.

### Timer/Controller Replacement

#### (See Illustration 3)



**Warning!** Electrical shock hazard. Disconnect and lock out all power to the pump unit before removing the keypad of the timer compartment.

(Note: Replacement of timer/controller board or keypad does not require the removal of the pump assembly from the mounting surface.)

1. Turn off the air and power supply to the pump unit.
2. Remove the keypad (6) from the face of the pump enclosure, by removing the four Phillips head screws (2).
3. Disconnect the ribbon cable connection from the keypad (6) by gently pulling the plug from the timer controller board (4).
4. Disconnect the wire connections from the wire terminals on the timer/controller board (4). Note where each wire is connected on the terminal strips.
5. Remove the timer/controller board (4) by removing the four Phillips head screws (5).
6. Reassembly is the reverse of the above procedure.

7. Be sure that all wires are connected to the correct locations on the terminal strips.
8. Connect the ribbon cable plug from the keypad (6) to the mating plug on the timer/controller board (4). The plug should be plugged into the timer/controller board so that the ribbon cable has no twist in it; it must be parallel to the face of the enclosure when the keypad is installed.
9. When reinstalling the keypad (6), be sure that the ribbon cable is gently folded into the enclosure behind the keypad, and not pinched between the keypad and enclosure.

## Solenoid Valve Replacement

(See Illustration 3)



**Warning!** Electrical shock hazard. Disconnect and lockout all power to the pump unit before removing the keypad of the timer compartment.

(Note: Replacement of the solenoid valve does not require removal of the pump assembly from the mounting surface)

1. Turn off the air and power supply to pump assembly.
2. See Timer/Controller Replacement, above, to remove the keypad (6) and timer/controller board (4).
3. Disconnect air line from pump assembly. Remove any muffler or connections from the exhaust port.
4. Remove the enclosure by removing two Phillips head screws (2) from the bottom side of the enclosure (1).
5. As the enclosure is removed from the assembly, gently pull the solenoid and green ground wires through the grommet (3) in the enclosure back towards the solenoid valve.
6. Remove the solenoid valve (14) using a 3/32 allen wrench to remove the two cap screws (15) holding it to the bottom of the air cylinder (11). Do not lose the gasket (13) that is placed between the valve and air cylinder (11).
7. When replacing the solenoid valve, make sure the solenoid valve is the correct part number and voltage as the valve to be replaced.
8. Reassemble in reverse of the above procedure. Take care in pulling the solenoid and green ground wires through the grommet (3).

## Oil Reservoir Service

(See Illustrations 3, 6 & 7)

(Note: Replacement of the reservoir tube does not require removal of the pump assembly from the mounting surface)

1. Turn off the air supply to the pump assembly.
2. Turn off the power supply to the pump unit.
3. Remove lubricant from the lubricant reservoir. Oil pump reservoirs may be drained by removing the drain plug (8) from the front of the pump unit with a 9/16 wrench.
4. Clean off reservoir tube and area around reservoir to prevent getting dirt into the lubrication system.



**Warning!** Failure to drain reservoir will result in lubricant leakage out of reservoir when the nut (46) securing the reservoir in place is removed.

5. Disconnect supply line from pump outlet.
6. Remove nut (46) from the top of the reservoir cap (44) using a 1-3/8 wrench.

7. Remove reservoir cap from top of reservoir.
8. Slide the reservoir tube off the pump over the center post.
9. Remove gasket (35) if necessary.
10. Reassemble in reverse of the above procedure.
11. Tighten nut (46) to 10 to 15 ft.-lbs. [1.4 to 2.1 kg-m].

## Grease Reservoir Service (See Illustrations 3, 8 & 9)

(Note: Replacement of the reservoir tube does not require removal of the pump assembly from the mounting surface)

1. Turn off the air supply to the pump assembly.
2. Turn off the power supply to the pump unit.
3. Remove lubricant from the lubricant reservoir. Grease pumps may be emptied by carefully removing the filler fitting (7) from the unit with a 7/8 wrench. (Depending on how full the reservoir is, the grease may flow out of the reservoir very rapidly.)



**Warning!** Failure to remove all lubricant from reservoir could result in a high spring force from the reservoir spring (43) and/or a rapid discharge of grease when nut (46) is loosened or removed.

4. Clean off reservoir tube and area around reservoir to prevent getting dirt into the lubrication system.
5. Disconnect supply line from pump outlet.
6. Remove nut (46) from top of reservoir cap (44) using a 1-3/8 wrench. Carefully hold reservoir cap (44) against any residual spring force while removing nut (46).
7. Remove reservoir cap (44) from top of reservoir.
8. Holding the follower down with the follower spring (43), carefully work the reservoir off of the follower, leaving the follower and spring in place on the pump assembly.
9. Remove follower spring (43).
10. Remove follower assembly by sliding up to the threads in the center tube, and then threading the follower assembly counter-clock-wise over the threaded portion of the center tube. Do not force or pull the follower off of the center tube or damage will result to the o-ring (38 or 48) inside of follower bushing (39).
11. Remove gasket (35) if necessary.
12. Disassemble the follower assembly by removing retaining ring (42), using external retaining ring pliers, from bushing (39). Washers (40) and follower packing can now be removed from bushing (39). Remove o-ring (38 or 48) from the internal groove in the inner hole of the bushing (39); use a pointed tool, such as a pick to remove.
13. Reassemble in reverse of the above procedure with the following hints:
14. When installing the follower assembly onto the center tube, lubricate the center tube liberally with grease. Lubricate the o-ring (38 or 48) and the inside of bushing (39) with grease. Thread, turning clockwise, the follower assembly down over the center rod threads. Do not force or drive with hammer, or o-ring damage will result in leakage of lubricant around follower. Side the follower assembly down to the bottom of the tube.
15. When installing the reservoir tube, lubricate the follower packing lips (41) and the inside of the reservoir tube (36) with grease. The reservoir tube will have two vent holes in the side wall of the tube close to one end of the tube. The reservoir tube (36) must be placed on the pump with the vent holes near the upper

side of the pump assembly. Place the reservoir tube down over the follower packing (41), working the packing lips up into the reservoir tube with your fingers until the entire follower assembly is inside the reservoir.

16. Tighten nut (46) to 10 to 15 ft.-lbs. [1.4 to 2.1 kg-m].

## Pump Tube and Air Cylinder Service (See Illustration 3, 6, 7, 8 & 9)



**Warning!** Electrical shock hazard. Disconnect and lock out all power to the pump unit before removing the keypad of the timer compartment.

(Note: Any servicing of the pump tube or air cylinder of the pump is best performed after the pump assembly is removed from the mounting surface.)

1. Turn off the air supply to the pump assembly.
2. Turn off the power supply to the pump assembly.
3. Remove pump from mounting surface.
4. When servicing the pump, keep work area clean and free of dirt to prevent contamination of the lubrication system.
5. Remove timer/controller card and keypad following procedure in **Timer/Controller Replacement** section of this manual.
6. Remove the enclosure and solenoid valve following the procedure in the **Solenoid Valve Replacement** section of this manual.
7. Remove the reservoir assembly following the procedure in the **Oil or Grease Reservoir Service** section of this manual.
8. Remove extension tube (34) on larger reservoirs. Use 1" wrench. **Do not** grip on outside diameter of extension tube. Damage to outside of tube may result in follower leakage or failure to move smoothly on tube.
9. Remove outlet bushing (33) or (47) from bushing & plunger ass'y. (25) with a 7/8 wrench, holding bushing & plunger ass'y. (25) with a 3/4 wrench.
10. Remove check body (32), with 7/16 wrench, from outlet bushing (33) or (47).

11. Use a small flat blade screwdriver to remove ball stop (27), spring (28), and ball (29) from inside of check body. Use a pick to remove o-ring (30) and packing (31) from outside of check body (32).
12. Loosen, but do not remove bushing & plunger (25) from cylinder end (20).
13. Remove six screws (21) securing cylinder end (20) to air cylinder (11), with a 3/8 wrench. Take care in removing the screws, the piston spring (18) will be exerting force on the cylinder end (20). Hold the cylinder end (20) by hand until all screws (21) are removed, then carefully remove from air cylinder (11).
14. Finish removing bushing and plunger assembly (25) from cylinder end. Note presence of gasket (23) and o-ring (22) in cylinder end (20). Plunger may be removed from cylinder end (20) by pulling out on the piston side of the cylinder end.
15. Remove o-ring (19) from cylinder end (20).
16. Remove plunger (25) from spring (18) by pulling spring tang out of hole in plunger.
17. Remove air piston (17) from air cylinder (11) by gently tapping air cylinder on soft surface until piston falls out.
18. Remove U-cup seal (16) from air piston (17).
19. Before reassembling, thoroughly clean all components in solvent. Replace seals and gaskets with new ones supplied in the soft parts kit. Lubricate the inside of the air cylinder (11) with grease. Lubricate o-rings prior to assembly with mating bores.
20. Reassemble in the reverse order of disassembly.
21. When placing cylinder end (20) into air cylinder (11) be sure to align U shaped opening on cylinder end (20) with the hole on air cylinder (11) that connects with the lubricant fill/drain port (1/2 NPTF). This hole is on the front side of the air cylinder (11) casting.
22. When assembling check valve with items 27, 28, 29, 30, 31, and 32, with 33 or 47, the check vent pressure must be set. Assemble all items above. Using a pump with a gage inline, feed oil at low pressure into pump outlet on end of item 33 or 47. Using a small flat blade screw driver adjust ball stop (27) until the ball check opens between 25 and 75 PSI [1.7 and 5.1 bar] on the gage. **Note:** Assemble Item 27 with non-hardening loctite or stake threads after adjusting vent pressure.

### Illustration 3 All Models

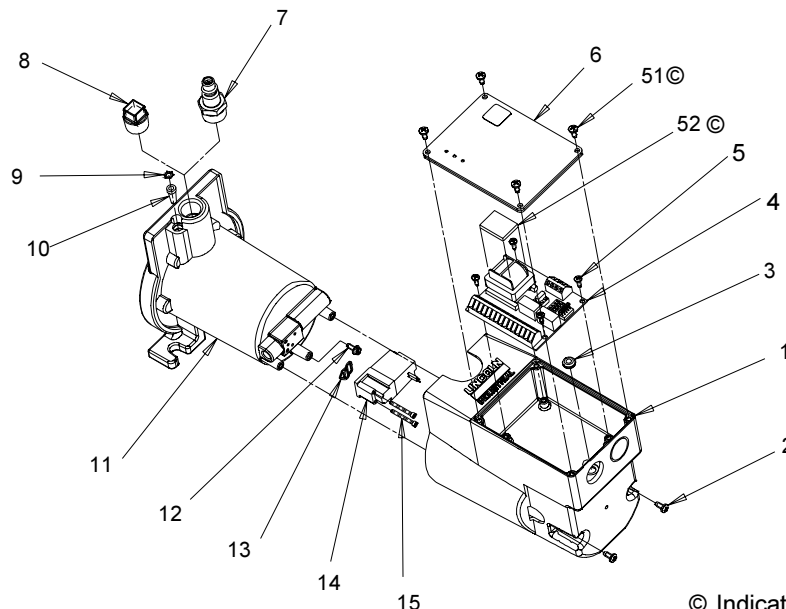

© Indicates change

**Illustration 4 Dimensions, Models 85438, 85439, 85442, 85443 (Dimensions in Inches[mm])**

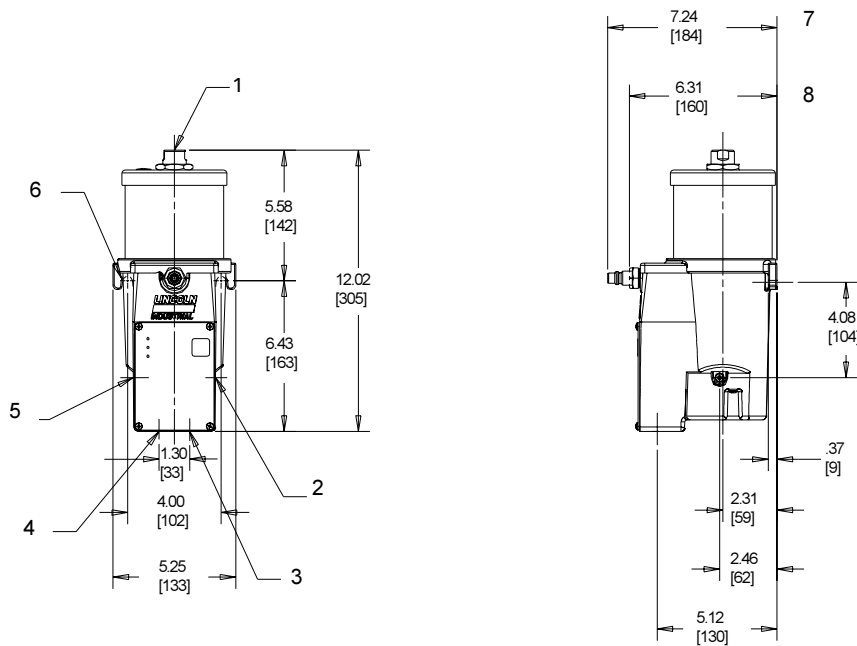

**Illustration 4**

1. Lube Outlet 1/4" NPTF
2. Air Inlet 1/8" NPTF
3. 1/2 Conduit Knock-out
4. 1/2 Conduit Opening
5. Air Exhaust 1/8" NPTF
6. 2 slots for 3/8" [10] Mounting Screws
7. Models 85442 & 85443 (Grease)
8. Models 85438 & 85439 (Fluid)

**Illustration 5 Dimensions, Models 85440, 85441, 85444, 85445 (Dimensions in Inches[mm])**

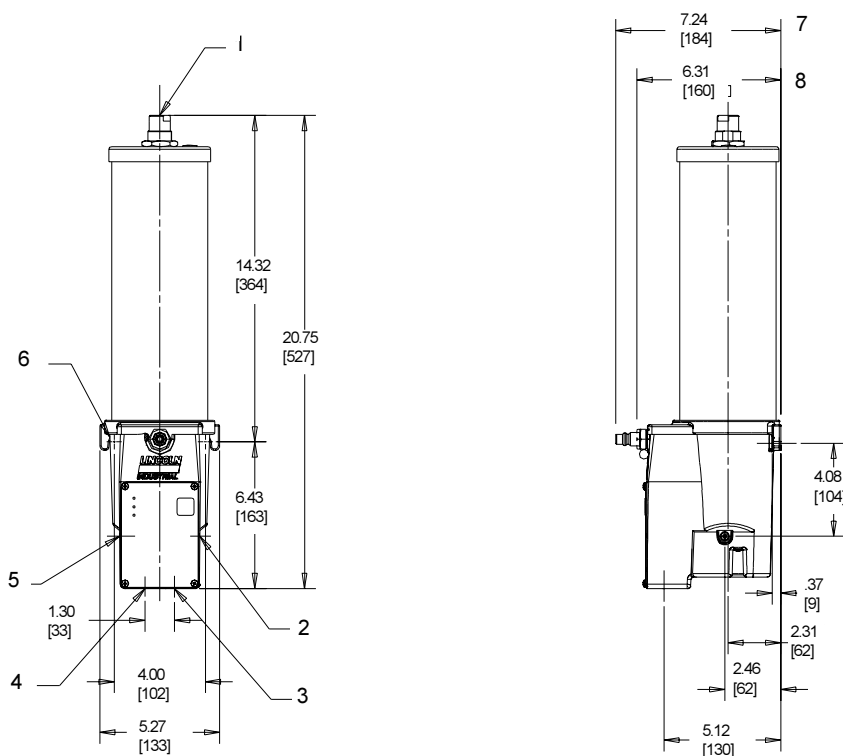
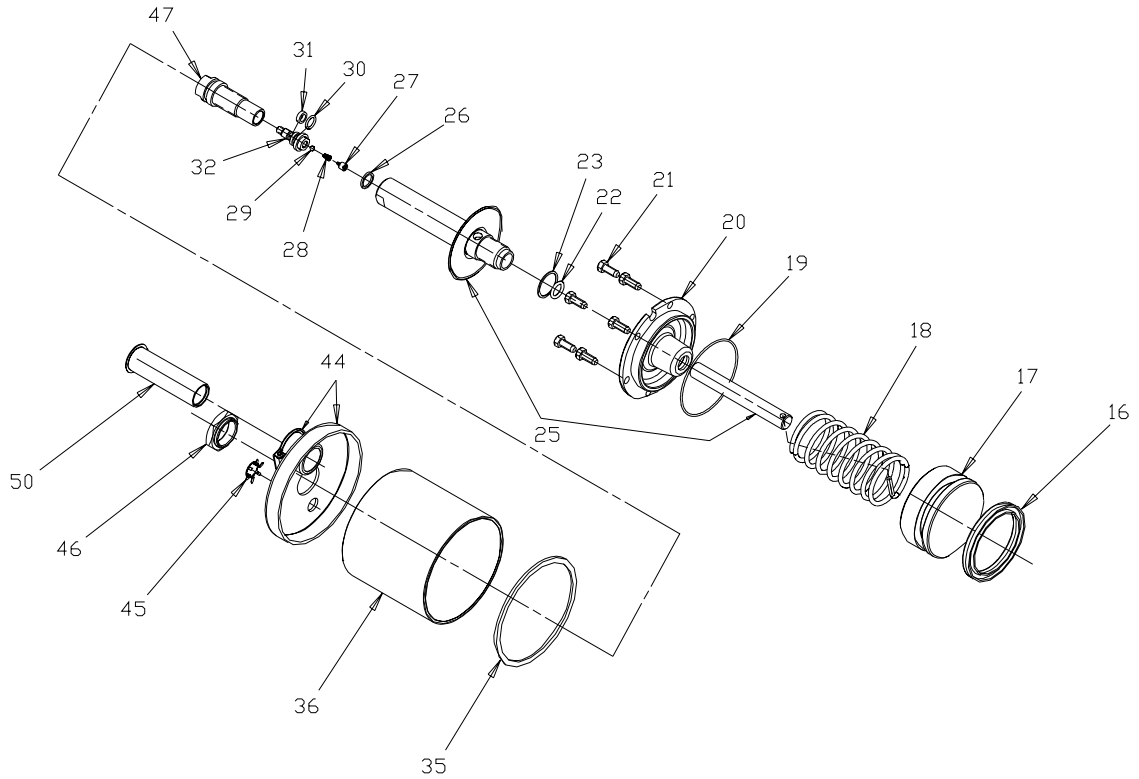

**Illustration 5**

1. Lube Outlet 1/4" NPTF
2. Air Inlet 1/8" NPTF
3. 1/2 Conduit Knock-Out
4. 1/2 Conduit Opening
5. Air Exhaust 1/8" NPTF
6. 2 Slots for 3/8" [10] Mounting Screws
7. Models 85444 & 85445 (Grease)
8. Models 85440 & 85441 (Fluid)



**Illustration 6**  
**Models 85438, 85439**



**Illustration 7**  
**Models 85440, 85441**

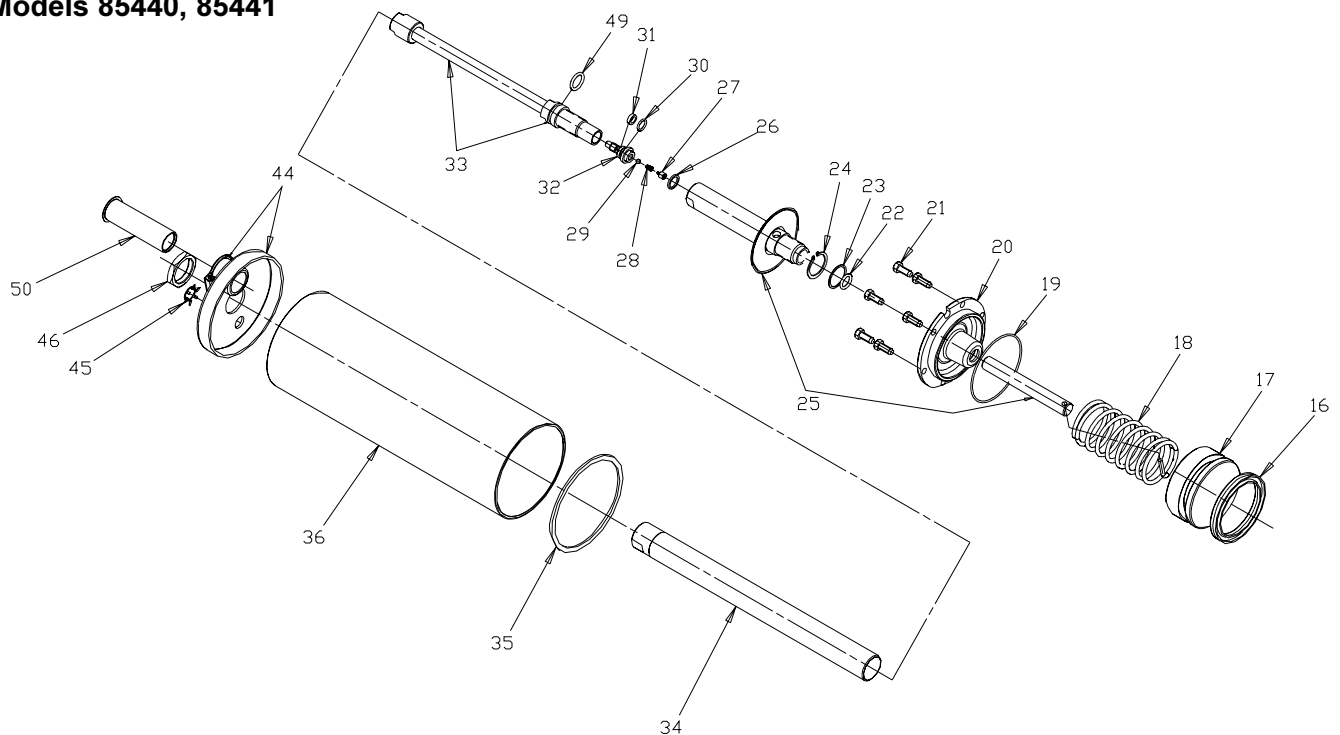

**Illustration 8**  
**Models 85442, 85443**

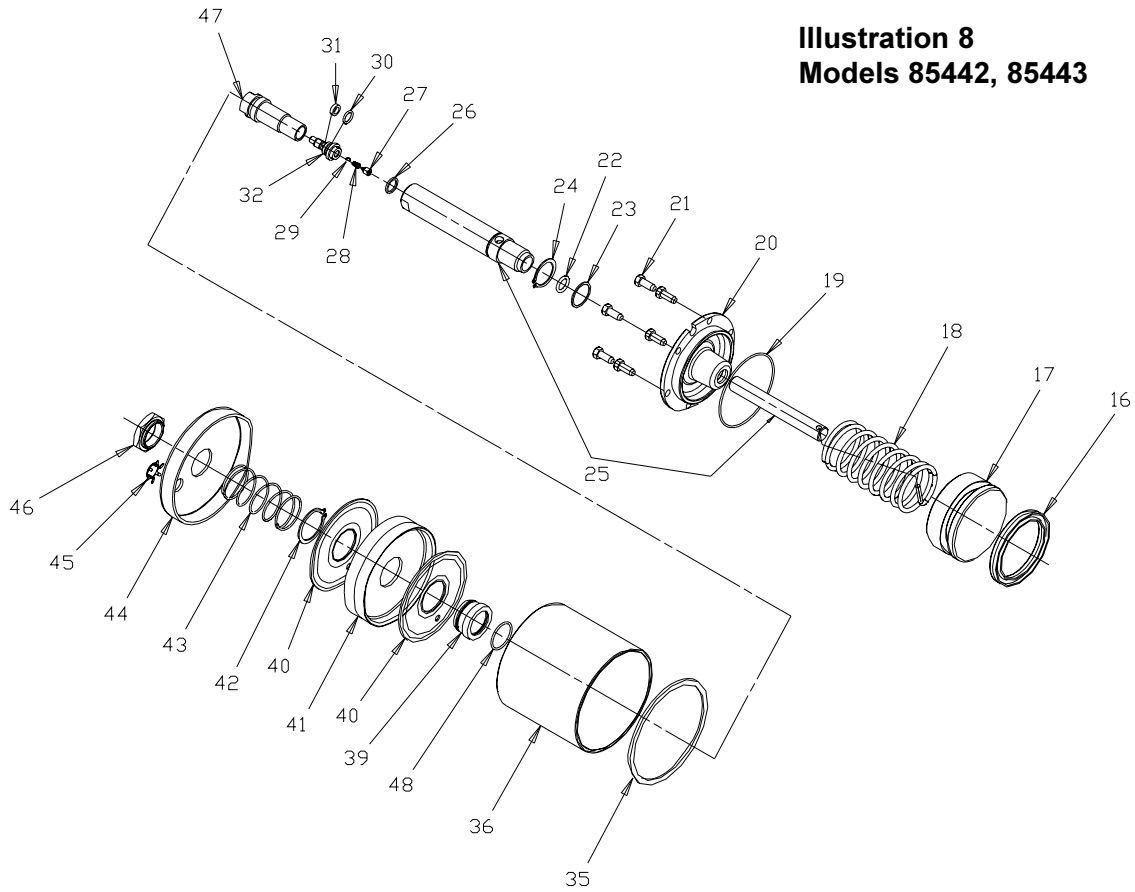

**Illustration 9**  
**Models 85444, 85445**

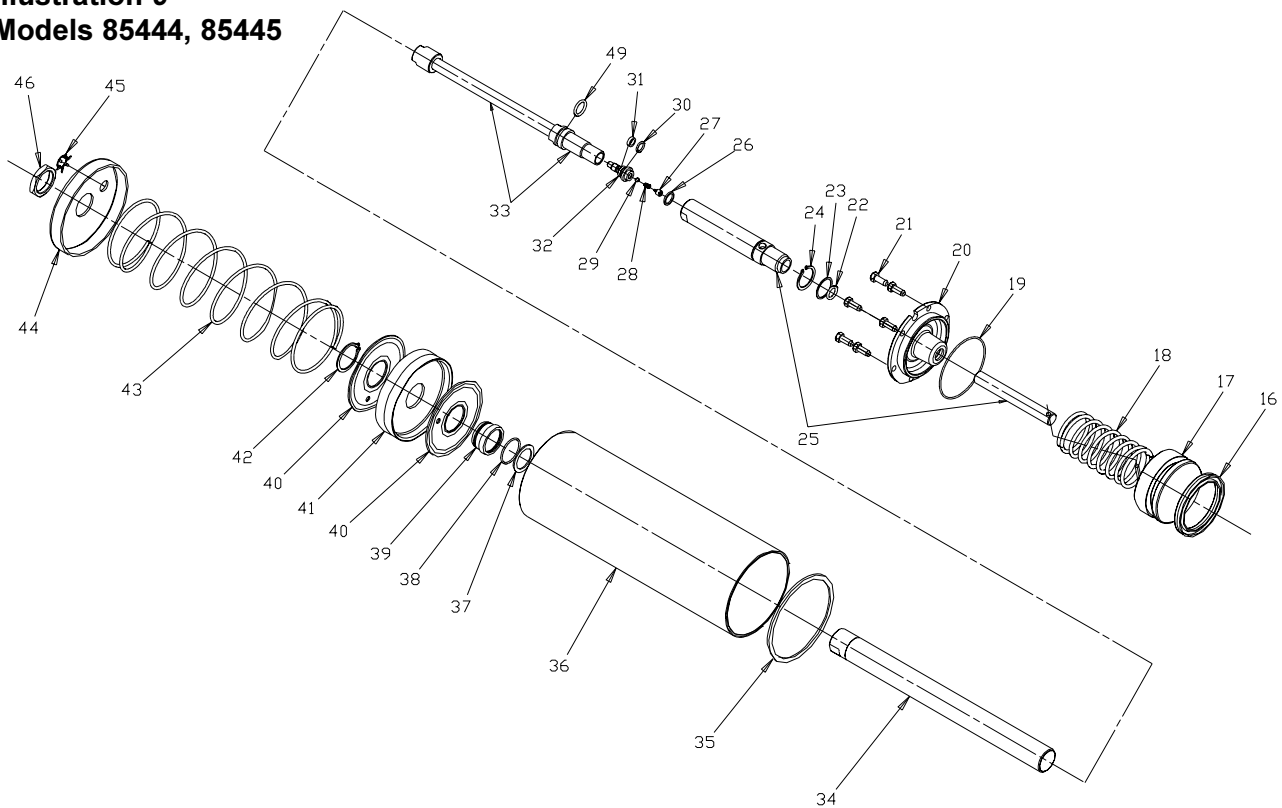

## Repair Parts List

Item	Quan.	Description	Models							
			85438	85439	85440	85441	85442	85443	85444	85445
1	1	Timer Enclosure		252705				252705		
2	2	8-32 Tapping Screw		250635				250635		
3	1	Grommet		252462				252462		
4	1	Timer Board	252702	252703	252702	252703	252702	252703	252702	252703
5	4	6-32 Tapping Screw		252463				252463		
6	1	Keypad Ass'y		252704				252704		
7	1	Filler Fitting		NA				92441		
8	1	1/2 Pipe Plug		67117				NA		
9	1	Retaining Ring		*				**		
10	1	Filter		*				**		
11	1	Air Cylinder		252484				252484		
12	1	Grounding Screw		324100				324100		
13	1	Solenoid Gasket(Nitrile)		252706				252706		
14	1	3 Way Solenoid Valve	252700	252701	252700	252701	252700	252701	252700	252701
15	2	4-40 Cap Screw		252471				252471		
16	1	U-Cup Seal (Nitrile)		*				**		
17	1	Air Piston		247478				247478		
18	1	Piston Return Spring		247483				247483		
19	1	O-Ring (Nitrile)		*				**		
20	1	Cylinder End		246174				246174		
21	6	Screw		247477				247477		
22	1	O-Ring (Nitrile)		*				**		
23	1	Gasket (Copper)		*				**		
24	1	Retaining Ring	NA	66725				66725		
25	1	Bushing & Plunger		247480				247484		
26	1	Gasket		*				**		
27	1	Ball Stop		14288				14288		
28	1	Spring		*				**		
29	1	Ball		*				**		
30	1	O-Ring (Nitrile)		*				**		
31	1	Packing (Nitrile)		*				**		
32	1	Check Body		14290				14290		
33	1	Outlet Check Bushing Ext.	NA	92684				NA	92684	
34	1	Extension Tube	NA	62493				NA	62493	
35	1	Gasket (Nitrile)		*				**		
36	1	Reservoir Tube (Acrylic)	247202	247208				247209	247210	
37	1	Washer		NA				NA	48382	
38	1	O-Ring (Nitrile)		NA				NA	**	
39	1	Bushing		NA				14341	14305	
40	2	Washer		NA				48467		
41	1	Follower (Nitrile)		NA				**		
42	1	Retaining Ring		NA				69034		
43	1	Follower Spring		NA				55329	55270	
44	1	Reservoir Cap		92180				45936		
45	1	Plug Button		68797				68797		
46	1	Nut	51083	51082				51083	51082	
47	1	Bushing		14953				NA		
48	1	O-Ring (Nitrile)		NA				**	NA	
49	1	O-Ring (Nitrile)	NA	*				NA	**	
50	1	Strainer		69128				NA		
51	4	#8 Tapping Screw		252747				252747		
52	1	Pad		252746				252746		
		Soft Parts Kit		252714				247623		

\* Included in 252714 Soft Parts Kit (Oil)

\*\* Included in 247623 Soft Parts Kit (Grease)

© Indicates change

## LUBE SYSTEMS WITH OUT ALARM MONITORING

CONDITION	POSSIBLE CAUSE	CORRECTIVE ACTION
Pump does not operate.	No air to pump	Turn on or connect air supply to pump.
	No electric power to pump.	Turn on electric power to pump. "Power" L.E.D. should light, "Pump On" L.E.D. should light when "Manual Lube" is pressed.
Pump does not operate, "Pump On" L.E.D. lights, air pressure is present at air inlet.	Exhaust port blocked or restricted.	Remove restriction.
	Pump Plunger or air piston movement restricted or seized.	Disassemble and determine cause of failure.
	Solenoid valve failure.	Replace solenoid valve.
	Timer/Controller Board failure.	Remove and replace.
Pump cycles when "Pump On" L.E.D. is off and does not cycle when "Pump On" L.E.D. is on.	Pump outlet blocked or restricted.	Remove blockage or restriction.
	Air line connected to exhaust port of Pump	Connect air line to air inlet port of pump assembly.
Pump operated but system fails to cycle.	Injector output adjustment set to minimum output setting.	Adjust injector outputs to correct output setting for system requirements.
	Supply line leaking.	Stop leak. Check all manifold plugs and injector mounting gaskets.
	Lubricant leaking past ball check (item 29)	Disassemble outlet check and vent, inspect for foreign particles. Clean or replace parts if worn or damaged.
	Vent pressure set too low.	Adjust vent pressure to 25 to 75 PSI [1.7 TO 5.1 bar]. See "Pump Tube and Air Cylinder Service" section of this manual.
	Reservoir low on lubricant.	Refill reservoir with lubricant.
	Pump or supply line is air bound.	Purge air from pump, supply line and injectors, see "Putting Pump into Operation" section of this manual.
	System too large for pump output.	Calculate system requirements per planning manual.
Pump dispenses lubricant, injector pins fail to return.	Restricted supply line	Remove restriction.
	Vent pressure set too high.	Adjust vent pressure to 25 to 75 PSI (1.7 to 5.1 bar), see "Pump Tube and Air Cylinder Service" section of this manual.
Pump dispenses lubricant, some injectors fail to deliver lubricant.	Pump "On Time" setting too short for system or temperature.	Set Timer/Controller to longer "Pump On" time setting.
	System too large for pump output.	Calculate system requirements per planning manual.
Bearing points are over lubricated.	Timer/Controller memory mode is set to off.	Turn on memory mode of Timer/Controller.
	Injector output adjustment setting too high.	Readjust to lower setting.
Bearing points are under lubricated.	Timer/Controller cycle time setting too low.	Set to longer cycle time or reevaluate lube requirements.
	Injector output adjustment setting too low.	Readjust to higher setting.
	Timer/Controller cycle timer setting does not deliver lubricant often enough.	Set to shorter cycle time or reevaluate lube requirements.
	System too large for pump output.	Calculate system requirements per planning manual.
"LUBE FAULT" L.E.D. turns on with each lube cycle, and pump will not initiate another lube cycle automatically.	Timer/Controller set to "Controller Mode" without a pressure switch in the supply line.	Connect a pressure switch into the supply line and connect to timer/controller or place mode switch in "Timer" mode.
	Low level switch wired incorrectly.	Check low level switch wiring and correct if necessary. Contact closure must be on low level condition.

### ADDITIONAL TROUBLE SHOOTING WHEN ALARM MONITORING IS USED

Some, but not all, of the injectors are delivering	Timer/Controller is set to "Timer" mode.	Set Timer/Controller to "Controller" mode.
	Pressure Switch setting is set too low.	Adjust pressure setting switch to setting high enough for all injectors to cycle.
	Pressure Switch wiring is shorted.	Check pressure switch wiring.
"Lube Alarm" L.E.D. turns on with each lube cycle, and pump will not initiate another lube cycle automatically.	Bad electrical connection between Pressure Switch and Timer/Controller.	Check all wiring between pressure switch and Timer/Controller.
	Pressure switch setting is too high.	Adjust Pressure Switch to setting high enough for all injectors to cycle.
	Pressure Switch is defective.	Repair or replace.
	Timer/Controller is defective.	Replace Timer/Controller.
	Low level switch wired incorrectly.	Check low level switch wiring and correct if necessary. Contact closure must be on low level condition.

Americas:  
One Lincoln Way  
St. Louis, MO 63120-1578  
USA  
Phone +1.314.679.4200  
Fax +1.800.424.5359

Europe/Africa:  
Heinrich-Hertz-Str 2-8  
D-69183 Walldorf  
Germany  
Phone +49.6227.33.0  
Fax +49.6227.33.259

Asia/Pacific:  
25 Int'l Business Park  
#01-65 German Centre  
Singapore 609916  
Phone +65.562.7960  
Fax +65.562.9967

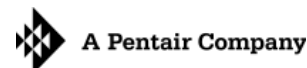

© Copyright 1999  
Printed in USA  
Web site:  
www.lincolnindustrial.com