

FlowMaster™ Rotary Driven Hydraulic Pump
Models: 85480, 85481, 85482 and 85483
Series "B"

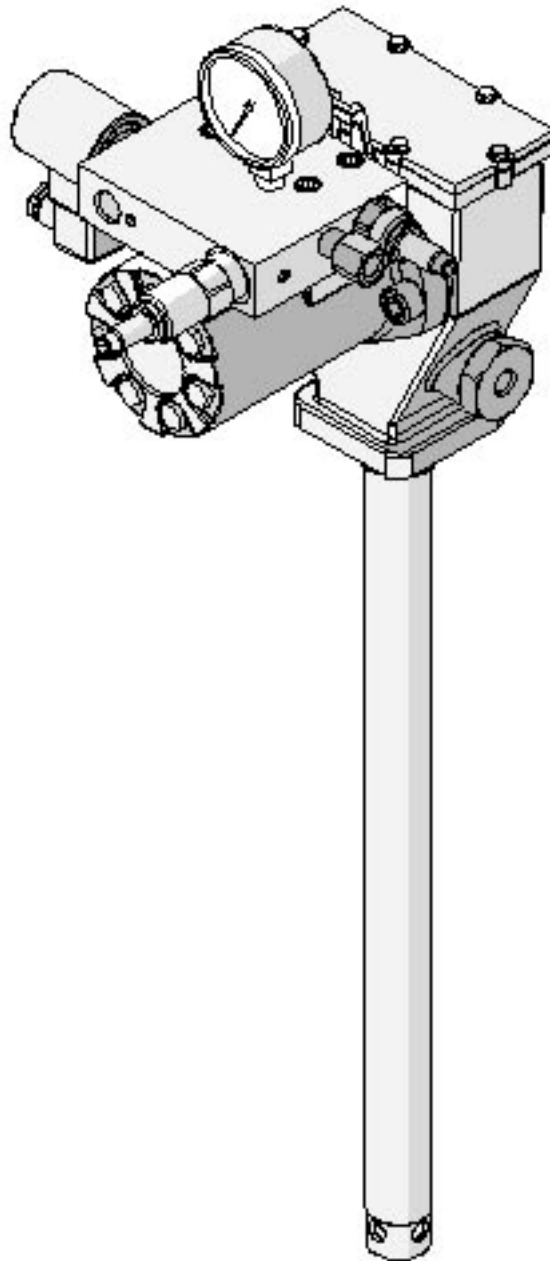

Foreign and U.S. Patent Pending

This pump conforms to the European Directive for Product Safety

Table of Contents

	Page
Safety.....	2
Description.....	2
Appropriate Use.....	2
Pump Performance and Specifications.....	3
Installing the Pump.....	4
Operation.....	5
Maintenance and Repair.....	5
Pump Dimensions.....	7
Repair Parts List.....	9
Trouble Shooting.....	10

Safety

Read and carefully observe these operating instructions before unpacking and operating the pump! The pump must be operated, maintained and repaired exclusively by persons familiar with the operating instructions. Local safety regulations regarding installation, operation and maintenance must be followed.

Operate this pump only after safety instructions and this service manual are fully understood.



Indicates a potentially hazardous situation which, if not avoided, could result in death or serious injury.



Indicates a potentially hazardous situation which, if not avoided, may result in minor or moderate injury.

Safety Instructions

This equipment generates very high grease pressure. Extreme caution should be used when operating this equipment as material leaks from loose or ruptured components can inject fluid through the skin and into the body causing serious bodily injury. Adequate protection is recommended to prevent splashing of material onto the skin or into the eyes.



If any fluid appears to penetrate the skin, get emergency medical care immediately. Do not treat as a simple cut. Tell attending physical exactly what fluid was injected.

Inspection

If overpressurizing of the equipment is believed to have occurred, contact the factory authorized warranty and service center nearest you for inspection of the pump.

Specialized equipment and knowledge is required for repair of this pump. Contact the factory authorized warranty and

service center nearest you for repair or adjustments other than maintenance specified in this manual.

Annual inspection by the factory authorized warranty and service center nearest you is recommended.

A list of factory authorized warranty and service centers is available upon request.

Damaged Pumps

Any pump that appears to be damaged in any way, is badly worn or operates abnormally, shall be removed from use until repairs are made. Contact the factory authorized warranty and service center nearest to you for repairs.

Description

- 85480 - Pump for 120 pound drum (16 gallon)
- 85481 - Pump for 60 pound drum
- 85482 - Pump for 400 pound drum (55 gallon)
- 85483 - Pump for 5 gallon pail

General Description

The Lincoln Industrial rotary Hydraulic Pump is a fully hydraulically operated grease pump. Grease output is proportional to the hydraulic input flow. The pump is primarily designed for centralized lubrication systems such as the Single Line Parallel, Single Line Progressive and Two Line systems. An integrated pump control manifold is incorporated with the motor to control input flow and pressure. A 24 volt DC solenoid valve is also incorporated as a method to turn the pump **on** and **off**.

The pump is driven by the rotary motion of the hydraulic motor. Rotary motion is converted to reciprocating motion through an eccentric crank mechanism. The reciprocating action causes the pump cylinder to move up and down. The pump is a positive displacement double acting pump as grease output occurs during both the up and down stroke of the pump.

During the down stroke, the pump cylinder is extended into the grease. Through the combination of shovel action and vacuum generated in the pump cylinder chamber, the grease is forced into the pump cylinder. Simultaneously, grease is discharged through the outlet of the pump. The volume of grease during intake is twice the amount of grease output during one cycle. During the upstroke, the inlet check closes, and one half of the grease taken in during the previous stroke is transferred through the outlet check and discharged to the outlet port. Typical output of the pump is shown on page 4.

Appropriate Use

- All pump models are exclusively designed to pump and dispense lubricants using hydraulic power.
- The maximum specification ratings should not be exceeded.
- Any other use not in accordance with instructions will result in loss of claims for warranty and liability.

FlowMaster™ Rotary Driven Hydraulic Pump

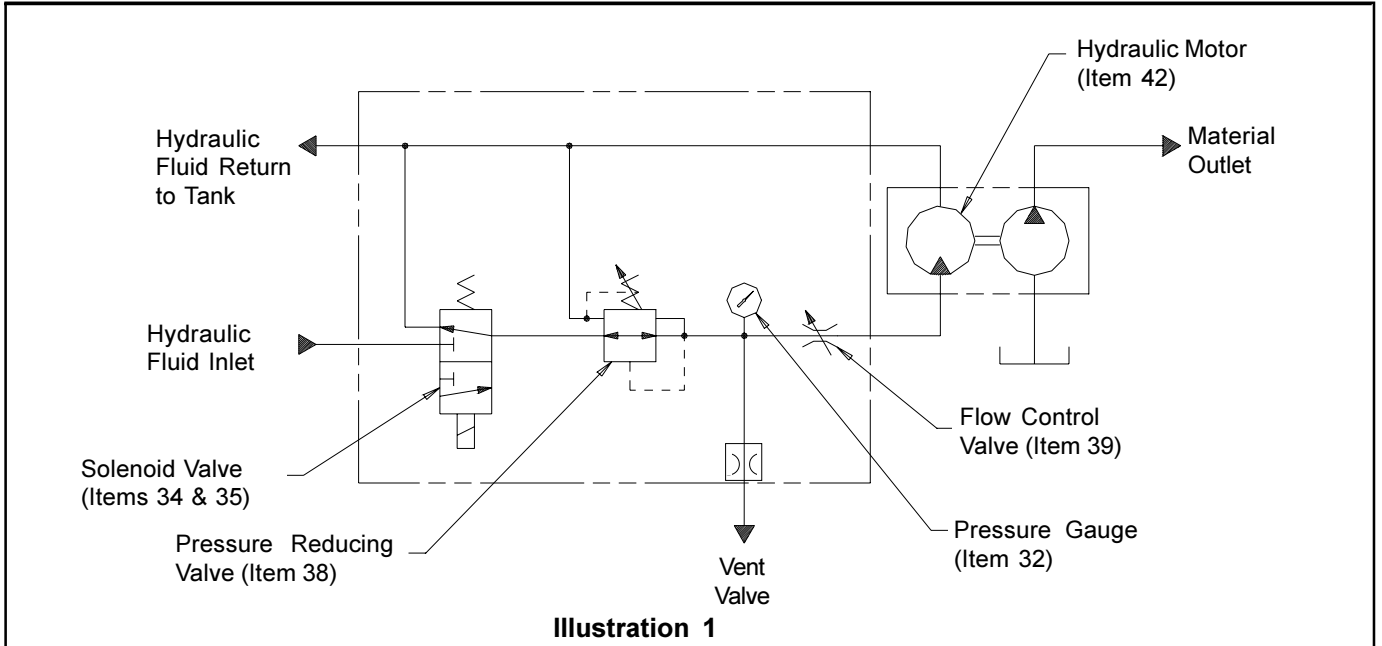

Illustration 1

Pump Performance and Specification

Supply inlet hydraulic pressure, maximum, PSIG (bar) -	3,000 (200)	Operating Temperature, °F (°C)-	-20 to +150 (-10 to 65)
Operating working hydraulic pressure, PSIG (bar) -	300 to 450 (20 to 32).	Operating Voltage, VDC -	24
Hydraulic Inlet Flow, GPM (l/min) -	Up to 7 (28)	Hydraulic Inlet Port, In -	SAE 4
Pump Ratio with manifold -	9:1 at low inlet pressure (300 to 350 psi [20 to 25 bar]) and low inlet flow (below 2 gpm [7 lpm]) Pump ratio approaches 11.0:1 ratio at higher inlet pressure and flow.	Tank Return Port, In -	SAE 6
		Pump Outlets, In -	1/4 NPTF
		Maximum Hydraulic Fluid Temperature, °F, (°C) -	200 (93)
		Weight, Lbs (Kg) -	36 (16)



Do not exceed 3,000 PSIG (200 bar) maximum supply inlet hydraulic pressure. Exceeding the rated pressure may result in damage to system components and personal injury.

HYDRAULIC PUMP PERFORMANCE SPECIFICATIONS

Test conducted with Alvania NLGI # 2 Grade Grease

Temperature F (Temperature C)	Grease Output Cubic inches/min. (cm ³ /min.)				1,000 psi Backpressure (70 bar)		
	Hydraulic Flow Input						
	1 gpm (4 l/min)	2 gpm (8 l/min)	3 gpm (11 l/min)	4 gpm (15 l/min)	5 gpm (19 l/min)	6 gpm (23 l/min)	7gpm (26 l/min)
80 (27)	7 (115)	14 (229)	21 (344)	28 (459)	34 (557)	40 (656)	45 (737)
40 (4)	7 (115)	14 (229)	21 (344)	28 (459)	33 (541)	38 (623)	41 (642)
20 (-7)	6 (98)	13 (213)	17 (279)	22 (361)	28 (459)	32 (594)	36 (590)
0 (-18)	6 (98)	11 (180)	15 (245)	19 (310)	23 (376)	27 (442)	30 (491)
-10 (-23)	5 (82)	7 (115)	8 (131)	9 (148)	10 (164)	12 (197)	13 (213)
-20 (-29)	4 (66)	6 (98)	8 (131)	10 (164)	12 (197)	14 (229)	15 (245)

Grease Output vs. Hydraulic Input

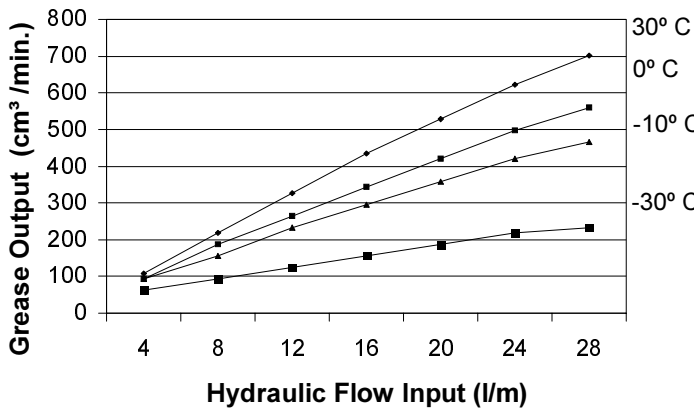

Grease Output vs Hydraulic Input

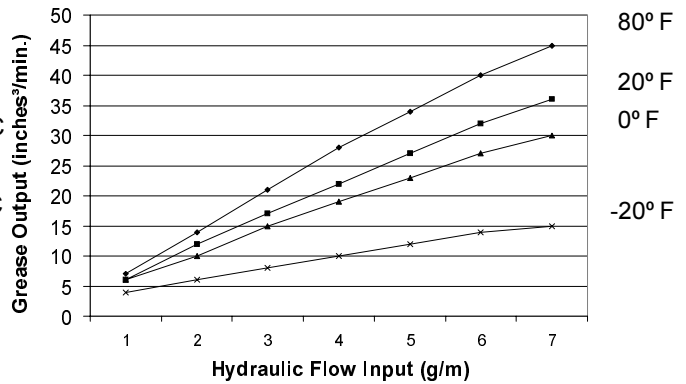

Installing the Pump

Typical installation is shown only as a guide for selecting and installing system components. Contact your Lincoln Industrial representative for assistance in designing a system to suit your specific needs.

The pump was tested in light weight oil which was left in to protect the pump from corrosion. Flush the pump before connecting it to the system to prevent contamination of the grease with residual oil.

The pump has flow and pressure controls integrated into the manifold (37). A normally closed **ON/OFF** Solenoid Valve (35) is also integrated into the manifold and will start or stop the pump operation.

1. Mount the pump securely on the drum cover so that it cannot move or vibrate during operation.
2. Attach hydraulic supply line to the **Inlet** and return line to the **Tank** ports.
3. Connect material supply line to the pump outlet. Plug the unused outlet on opposite side of the pump.
4. Install high pressure shut-off valve in the material supply line. (Required)
5. Connect 24 VDC power supply to the solenoid valve (35). See Illustration #1. Use connector plug (36) supplied with the pump.

NOTE: To install the pump Model 85481 as a replacement pump for 84961 used on Model 84944, use adapter/spacer p/n 249616 with bolts p/n 50014, included in the pump package (see illustration #4).

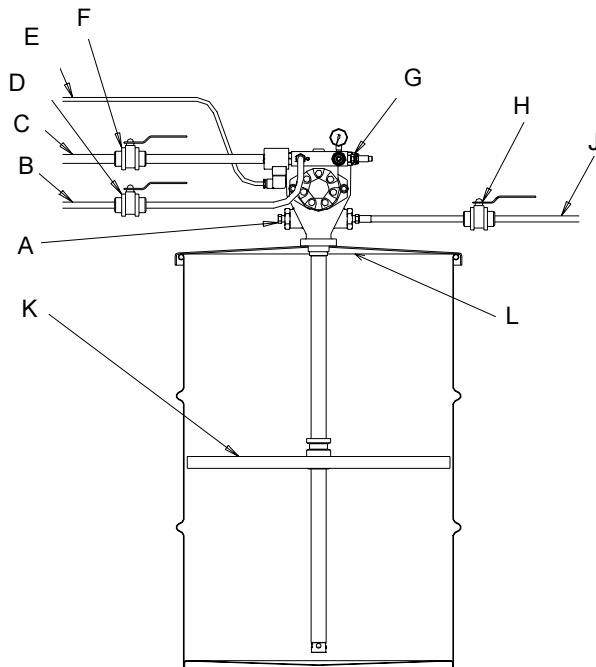

- A - Pump Outlet Plug
- B - Hydraulic Supply Line
- C - Hydraulic Return to Tank line (3/4" ID min.)
- D - Supply Line Shut-off Valve
- E - 24 VDC from Controller
- F - Return Line Shut-off Valve (3/4" ID min.)
- G - Vent Valve Port with Restrictor
- H - Outlet Shut-off Valve
- J - Material Supply Line
- K - Follower Plate (85492 for 120 lb. drum only)
- L - Drum Cover (83115 for 400 lbs., 84616 for 120 lbs.)

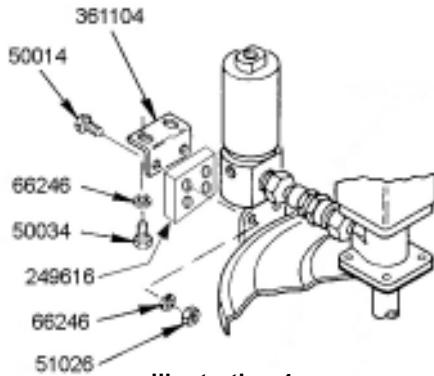

Illustration 4



Mount the pump securely on the drum cover. Failure to do so could result in personal injury and equipment damage.



Do not exceed 450 PSIG (32 bar) working hydraulic pressure. Use high pressure components to reduce risk of serious injury including fluid injection and splashing in the eyes or on the skin. All accessories connected to the pump outlet must have at least 5,000 PSIG (350 bar) minimum hydraulic pressure. All accessories connected to the pump inlet must have at least 3,000 PSIG (200 bar) minimum working pressure.

Operation

All pumps are factory set at 350 PSIG (24 bar) working inlet hydraulic pressure with a flow rate of 2.5 GPM (9.5 l/min).

Do not change the settings for the pump until after the start up procedure.

1. Shut off the material supply line valve.
2. Turn on the hydraulic pressure.
3. Energize the solenoid **On/Off** valve.
4. Prime the pump by slowly opening the shut-off lubricant supply line valve. Make sure that all air has been expelled from the pump and even lubricant flow is achieved.
- © 5. Adjust the pump pressure and flow to the desired application requirements. See **Pressure and Flow Control Valve Adjustment** for instructions to adjust pressure and flow. Do not exceed pump operating pressure of 450 PSIG (32 bar).
6. Always use the lowest pump output pressure and hydraulic fluid flow to obtain the desired results. This will reduce the pump wear.

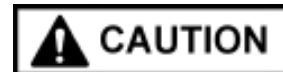

Do not exceed maximum operating temperature of the hydraulic fluid (200° F/93° C) . Never allow the pump to run dry of lubricant. A dry pump quickly speeds up, creating friction heat, which can damage the seals. Monitor the supply lubricant level and refill when necessary.

Setting the Pump Manifold Pressure and Flow Controls

The pressure must first be adjusted to insure the desired flow setting is achieved.

Pressure Control Valve Adjustment

- Loosen the lock nut on the Pressure control by turning the nut **COUNTERCLOCKWISE**.
- Turn the valve stem **COUNTERCLOCKWISE** until it no longer turns. The valve stem will unscrew until it reaches the stop. It will not come off. This is the minimum pressure setting, which is about 170 psi (12 bar).
- With the pump stalled against pressure, turn the Pressure Control Valve stem **CLOCKWISE** until the desired pressure is attained on the manifold Pressure Gage. (Do not exceed 450 PSI.
- Tighten the lock nut by turning **CLOCKWISE**.

Flow Control Valve Adjustment

- Loosen the lock nut on the Flow Control Valve by turning the nut **COUNTERCLOCKWISE**.
- Adjust the flow by turning the valve stem **CLOCKWISE** to reduce the flow and **COUNTERCLOCKWISE** to increase it. The Flow Control Valve can be turned in until the valve is completely closed, and out a maximum of 2 1/2 turns. The valve stem will not come out when fully open (unscrewed) as there is a stop at this position.
- After adjusting the flow to the desired setting, tighten the lock nut by turning it **CLOCKWISE**.

Maintenance and Repair

Relieve pressure from the pump and supply lines before servicing or repairing the pump, to reduce the risk of an injury from injection, splashing fluid or moving parts.



Always use Lincoln Industrial parts for service and repair.

Disassembly Procedure (See illustration #6)

Tools Required:

- Hex Bit Socket Wrenches (3/8" square drive) with 3/8" hex, 5/32" hex, 1/4" hex.
 - 3/8" O.D. Steel Rod
 - 12" Crescent Wrench
 - Spanner Wrench (for 3/8" diameter tube, 1/8" pin)
 - 1/2" to 3/8" square drive adapter
 - Torque wrench (1/2" square drive, 0 - 50 ft-lb capacity)
 - Torque wrench (3/8" square drive, 0 - 120 in-lb capacity)
 - 1/4" nut driver
 - Screwdriver (flat blade, 1/8" blade width)
1. Remove the four Socket Head Screws (33) and separate Manifold from the Hydraulic Motor (42).
 2. Remove Pipe Plug (45) and drain the crankcase oil from the Pump Housing (46).
 3. Remove six self-threading Screws (29) and remove the Housing Cover (30) and the Cover Gasket (31).
 4. Remove Retaining Ring (57) and pull the Shovel Plug (56) from the Housing Tube (55).
 5. Remove two Socket Head Screws (44) and separate the Hydraulic Motor (42) from the Pump Housing (46).
 6. Remove two Outlet Pin Nuts (50) from the Pump Housing (46).
 7. Remove the Pump Subassembly (1 through 28) from the Pump Housing (46). Pushing the subassembly up with a wooden or plastic rod 3/4 O.D. against the Check Seat Housing (28) is helpful.
 8. Remove the Housing Tube (55) from the Pump Housing (46) by inserting a 3/4 rod through the inlet holes at the bottom of the Housing Tube (55) and unscrewing it.
 9. Remove the Bronze Bearing (51), the O-Ring (52), and the Backup Washer (53) from the Housing Tube (55).
 10. Remove the Crankrod Assembly (1 through 8) from the pump by unscrewing the Button Head Screws (12) and then pulling out the Wrist Pin Bushings (13).
 11. Remove the Check Seat Housing (28) from the Reciprocating Tube (21). There is a 3/8 Allen Head socket in the throat of the Check Seat Housing (28) to facilitate removal.
 12. Unscrew the Wrist Pin Anchor (14) from the Reciprocating Tube (21) and pull the Plunger Assembly (9 through 20) from the tube.
 13. Using a 1/2" wooden or plastic rod, push the Cup Seal (22) and the Pump Cylinder (24) from the Reciprocating Tube (21).
 14. Remove the Pump Plunger (20) from the Plunger Link Rod (17). A spanner wrench, which uses the holes in the Pump Plunger, is required.
 15. Unscrew the Plunger Link Rod (17) from the Plunger Tube (11) and slide off the Cup Seal (16), the Backup Washer (15) and the Wrist Pin Anchor (14).
 16. Unscrew the Plunger Tube (11) from the Outlet Pin (9).
 17. To dismantle the Crankrod Assembly (1 through 8), remove Flat Head Screws (1) and the Inner and Outer Weights (2 & 3).
 18. Remove the large Retaining Rings (6) and press the Crank Eccentric (7) out of the Ball Bearing (8). Be sure to support the Ball Bearing (8) on the inner race.

19. Remove the small Retaining Rings (6) and press the Crank Eccentric (7) out of the Ball Bearing (8). Be sure to support the Ball Bearing (8) on the inner race.

Pump Assembly Procedure

1. When the pump is disassembled, it is recommended to replace all seals and gaskets, which are included in the 270663 repair kit.
2. In the process of disassembly, examine the following components and replace if excessive wear is indicated: Ball Bearing (8), Crank Eccentric (7), Crankrod (5), Wrist Pin Bushings (13), Plunger Tube (11), Pump Plunger and Upper Check Parts (20, 19 and 18), Pump Cylinder (24), Check Seat Housing and Lower Check Ball (28 and 26), upper Bronze Bushing (51), Housing Tube (55), Shovel Plug (56), and Reciprocating Tube (21).
3. Assembly Procedure is the reverse of the Disassembly Procedure except for the following:
4. Install parts (22) through (28) into the Reciprocating Tube (21) after the plunger assembly (9 through 20) is installed.
5. Install the Pump Subassembly (1 through 28) into the pump Housing (46) before tightening the Housing Tube (55) to the Pump Housing (46). Be sure the Reciprocating Tube (21) is inserted through both bushings before tightening the Housing Tube (55).
6. Use loctite 242 (or similar product) medium strength thread lock on all torqued threaded connections. Extreme care must be exercised to prevent excess compound from flowing into critical areas such as clearance fits and ball check. Allow a minimum of 30 minutes cure time before operating the pump.
7. Torque Specifications:
 - A. Plunger Tube (11) to Outlet Pin (9) - 100 to 110 In.-Lbs.
 - B. Button Head Screws (12) to Wrist Pin Anchor (14) 100 to 110 In.-Lbs.
 - C. Plunger Tube (11) to Plunger Link Rod (17) - 100 to 110 In.-Lbs.
 - D. Plunger Link Rod (17) to Pump Plunger (20) - 100 to 110 In.-Lbs.
 - E. Flat Head Screws (1) to Outer Weight (2) - 100 - 110 In.-Lbs.
 - F. Wrist Pin Anchor (14) to Reciprocating Tube (21) - 20 to 25 Ft.-Lbs.
 - G. Check Seat Housing (28) to Reciprocating Tube (21) - 20 to 25 Ft.-Lbs.
 - H. Outlet Pin Nut (50) to Pump Housing (47) - 30 to 35 Ft.-Lbs.
 - I. Housing Tube (55) to Pump housing (47) - 20 to 25 Ft.-Lbs.

FlowMaster™ Rotary Driven Hydraulic Pump

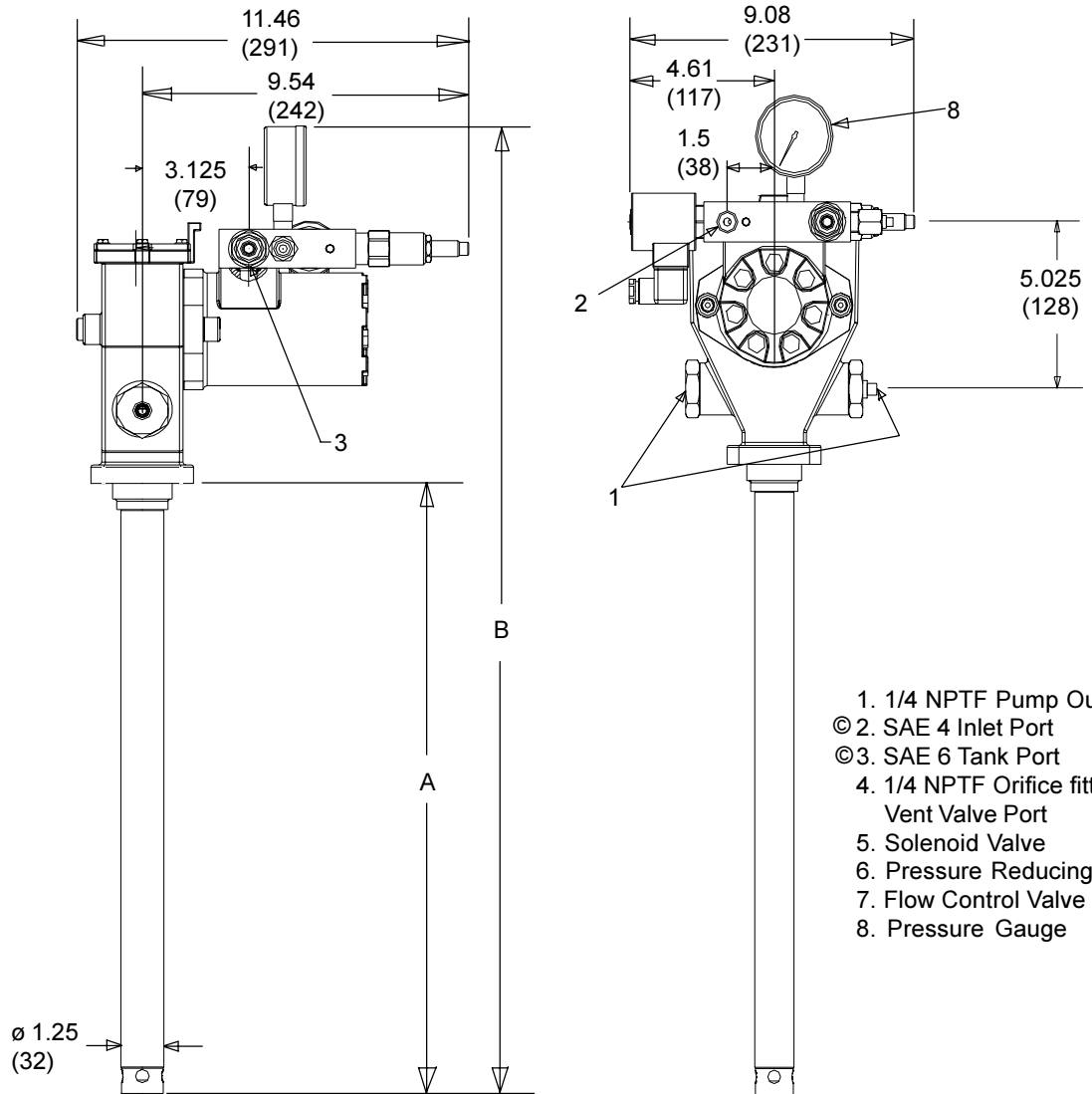

- 1. 1/4 NPTF Pump Outlets
- 2. SAE 4 Inlet Port
- 3. SAE 6 Tank Port
- 4. 1/4 NPTF Orifice fitting for Vent Valve Port
- 5. Solenoid Valve
- 6. Pressure Reducing Valve
- 7. Flow Control Valve
- 8. Pressure Gauge

□□□□□	□□□ □□□ □□ □□ □□	□□□ □□□ □□ □□ □□
□□□□□	□□□□□ □□□□	□□□□□ □□□□
□□□□□	□□□□□ □□□□	□□□□□ □□□□
□□□□□	□□□□□ □□□□	□□□□□ □□□□
□□□□□	□□□□□ □□□□	□□□□□ □□□□

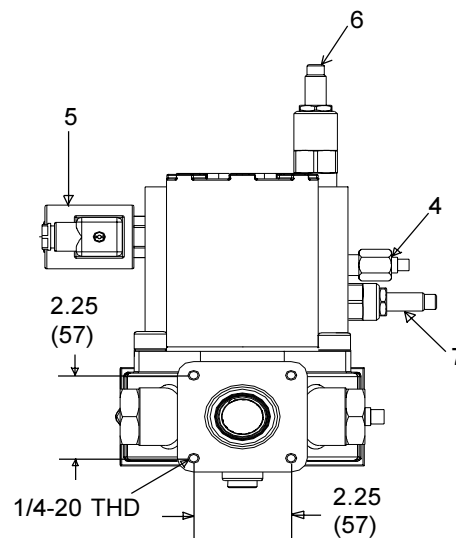

Illustration #5

© indicates change

FlowMaster™ Rotary Driven Hydraulic Pump

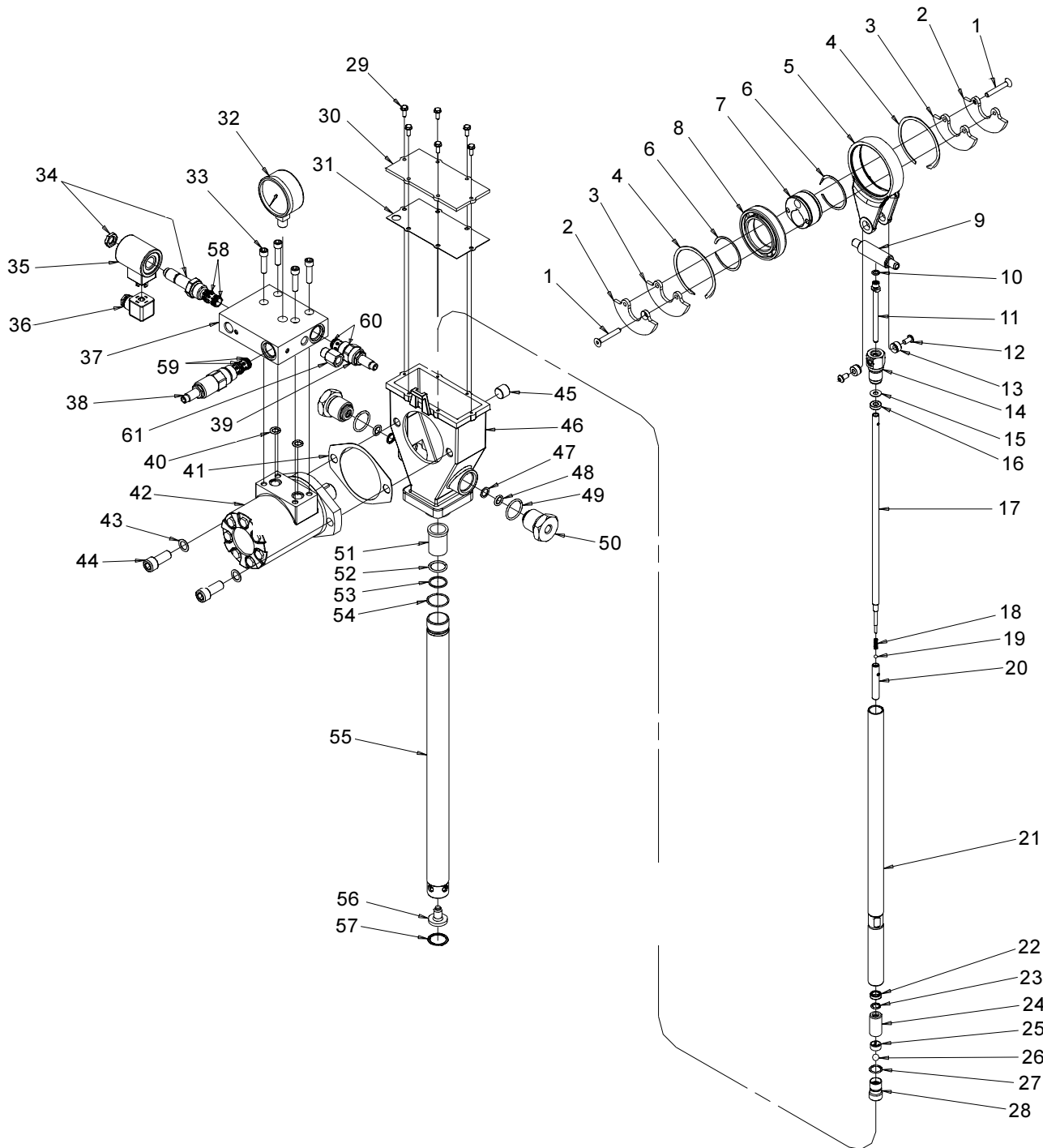

Illustration #6

Repair Parts List (Common to all Models)

Item No.	Qty	Description	All Models
1.	2	Flat Head Screw (1/4 x 1-3/4)	270635
2.	2	Outer Weight	270606
3.	2	Inner Weight	270605
4.	2	Retaining Ring	270609
5.	1	Crankrod	270665
6.	2	Retaining Ring	270608
7.	1	Crank Eccentric	270666
8.	1	Ball Bearing	270607
9.	1	Outlet Pin	270670
10.	1	O-Ring (Nitrile)	*
11.	1	Plunger Tube	270667
12.	2	Button Head Screw (1/4 x 1/2)	270634
13.	2	Wrist Pin Bushing	270668
14.	1	Wrist Pin Anchor	270669
15.	1	Backup Washer	*
16.	1	Cup Seal (Polyurethane)	*
17.	1	Plunger Link Rod	See Chart Below
18.	1	Spring	270616
19.	1	Ball	66010
20.	1	Pump Plunger	270671
21.	1	Reciprocating Tube	See Chart Below
22.	1	Cup Seal (Polyurethane)	*
23.	1	O-Ring (Polyurethane)	*
24.	1	Pump Cylinder	270672
25.	1	Ball Cage	270675
26.	1	Ball	66001
27.	1	O-Ring (Nitrile)	*
28.	1	Check Seat	270664
29.	6	Self-Threading Screw (8 x 1/2)	270633
30.	1	Housing Cover	270629
31.	1	Cover Gasket (Nitrile)	*

Item No.	Qty	Description	All Models
32.	1	Pressure Gauge	270768
33.	4	Socket Head Screw (5/16 x 1-1/4)	270680
34.	1	Solenoid Valve Cartridge (Note #2)	270690
35.	1	Solenoid Valve Coil (24 VDC)	270691
36.	1	Solenoid Connector	242209
©37.	1	Manifold	270771
38.	1	Pressure Reducing Valve (Note #3)	270692
39.	1	Flow Control Valve (Note #4)	270693
40.	2	O-Ring (Nitrile)	*
41.	1	Motor Gasket	*
42.	1	Hydraulic Motor (Note #1)	270676
43.	2	Washer	48548
44.	2	Socket Head Screw (1/2 x 1-1/4)	270658
45.	1	Pipe Plug (3/8 NPTF)	67417
46.	1	Pump Housing	270673
©47.	2	Backup Ring (Polyurethane)	*
©48.	2	O-Ring (Polyurethane)	*
49.	2	O-Ring (Nitrile)	*
50.	2	Outlet Pin Nut	270619
51.	1	Bronze Bearing	270674
©52.	1	O-Ring (Polyurethane)	*
53.	1	Backup Washer	*
54.	1	O-Ring (Nitrile)	*
55.	1	Housing Tube	See Chart Below
56.	1	Shovel Plug	270707
57.	1	Retaining Ring	270705
58.	1	Seal Kit (Nitrile)	270687
59.	1	Seal Kit (Nitrile)	270688
60.	1	Seal Kit (Nitrile)	270689
61.	1	Orifice Fitting	270735
		Soft parts Kit	270663

Repair Parts List (Non-common items)

Item No.	Qty.	Description	Model 85480	Model 85481	Model 85482	Model 85483
17	1	Plunger Link Rod	270648	270614	270645	270641
21	1	Reciprocating Tube	270649	270617	270646	270642
55	1	Housing Tube	270659	270660	270661	270662

- * Included in 270663 Soft Parts Kit.
- 1. Includes Gasket (Item 41) and O-Rings (Item 40).
- 2. Includes Seal Kit (Item 58).
- 3. Includes Seal Kit (Item 59).
- 4. Includes Seal Kit (Item 60).

© indicates change

Troubleshooting

Condition	Possible Cause	Corrective Action
Pump does not run.	No pressure on gauge (32): - Closed Supply line shut off valve. - No power to solenoid valve (34). - Faulty Solenoid (35). - Pressure Reducing Valve (38) is set too low. - Insufficient Hydraulic Fluid supply.	Open shut-off valve. Correct electrical fault. Replace solenoid (35). Reset Pressure Reducing Valve (38). Check hydraulic supply for proper pressure and flow.
	Pressure is shown on gauge (32): - Closed fluid outlet line. - Flow Control Valve is fully closed. - Pump is stalled due to grease backpressure. - Pump is stalled due to grease backpressure.	Check outlet line and clear obstructions. Readjust valve to 3/4 turn open. Check vent valve in system. Check vent valve in system.
	Pump is seized or damaged.	Dismantle the pump and repair defective or seized component. See disassembly and assembly procedure.
Pump speeds up or runs erratically.	Low level of grease or reservoir is empty.	Refill reservoir.
	Follower plate is stuck and separated from grease.	Check follower plate and container for damage.
	Pump piston or checks are worn.	Disassemble the pump and repair.
Pump runs, but output is low.	Insufficient hydraulic fluid supply.	Check hydraulic supply and adjust flow using valve 39.
	Inlet pressure too low.	Increase pressure using valve 38.
	Faulty inlet (25, 26, 27) or discharge check valve (18, 19, 20).	Replace faulty components.
Weepage from housing cover 30.	Cup seal (16) or O-Ring (48) wore out.	Check the seals and replace if necessary.
Pump becomes noisy.	No crank case oil.	Add crank case oil. Remove Pipe Plug (45) from Pump Housing (46). Oil level should be at the bottom of the Pipe Plug opening. Add 10W30 motor oil until the crankcase is full.
	Worn wrist pin bushing 13.	Check the bushings and replace if necessary.

Copyright 1999

Printed in the U.S.A.

Lincoln Industrial
 One Lincoln Way
 St. Louis, MO 63120-1578
 (+1) 314 679 4200
 www.lincolnindustrial.com

Lincoln GmbH
 69190 Walldorf
 Heinrich-Hertz Strasse 2-8
 (+49) 6227 33-0

Lincoln Industrial
 25 International Business Park
 #01-68 German Centre
 Singapore 609916
 (+65) 562-7960