

---

**FlowMaster™ Electric Pump**  
**Models: 85578 and 85579, 24 VDC, 100 RPM**  
**85580, 90 VDC, 100 RPM**  
**85582, 12 VDC, 300 RPM**  
**Series "A"**

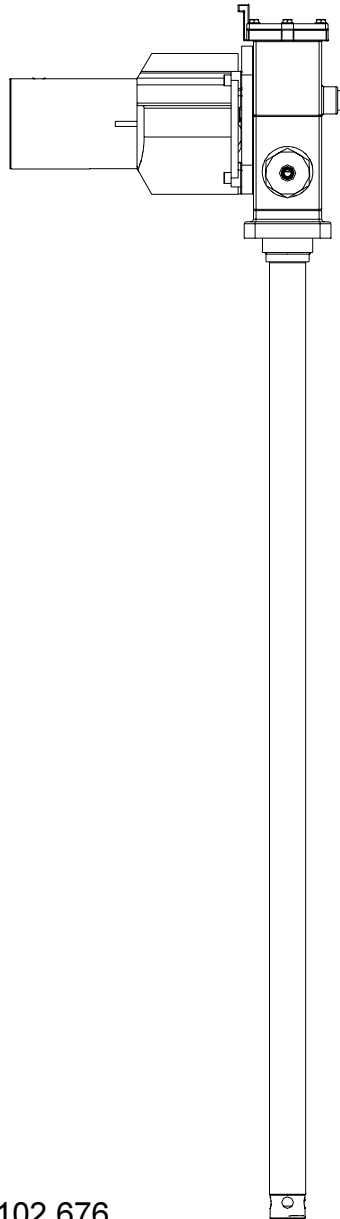

U.S. Patent No. 6,102,676



Foreign Patent Pending

This pump conforms to the European Directive for Product Safety

## Table of Contents

	Page
Safety .....	2
Description.....	2
Appropriate Use.....	2
Pump Performance and Specifications.....	3
Installing the Pump.....	4
Operation.....	5
Maintenance and Repair.....	5
Pump Dimensions.....	7
Repair Parts List.....	9
Trouble Shooting.....	10

## Safety

Read and carefully observe these operating instructions before unpacking and operating the pump. The pump must be operated, maintained and repaired exclusively by persons familiar with the operating instructions. Local safety regulations regarding installation, operation and maintenance must be followed.

Operate this pump only after safety instructions and this service manual are fully understood.

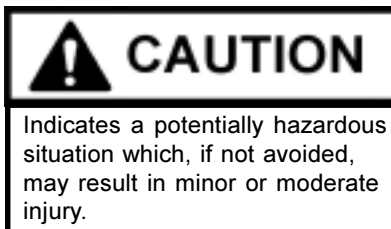
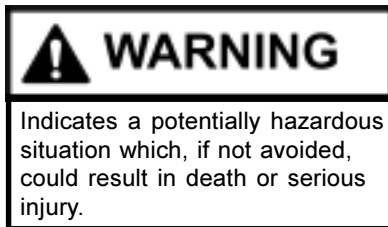

## Safety Instructions

This equipment generates very high grease pressure. Extreme caution should be used when operating this equipment as material leaks from loose or ruptured components can inject fluid through the skin and into the body causing serious bodily injury. Adequate protection is recommended to prevent splashing of material onto the skin or into the eyes.

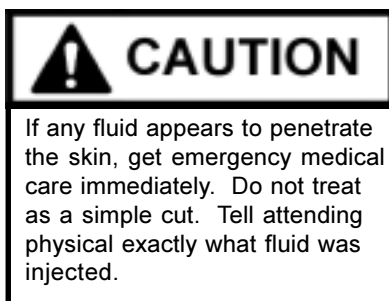

## Inspection

If overpressurizing of the equipment is believed to have occurred, contact the factory authorized warranty and service center nearest you for inspection of the pump.

Specialized equipment and knowledge is required for repair of this pump. Contact the factory authorized warranty and service center nearest you for repair or adjustments other than maintenance specified in this manual.

Annual inspection by the factory authorized warranty and service center nearest you is recommended.

A list of factory authorized warranty and service centers is available upon request.

## Damaged Pumps

Any pump that appears to be damaged in any way, is badly worn or operates abnormally, shall be removed from use until repairs are made. Contact the factory authorized warranty and service center nearest to you for repairs.

## Description

85578 - Pump for 400 pound drum (55 gallon), 24 VDC, 100 RPM

85579 - Pump for 5 gallon pail, 24 VDC, 100 RPM

85580 - Pump for 5 gallon pail, 90 VDC, 100 RPM

85582 - Pump for 60 pound container, 12 VDC, 300 RPM

## General Description

The Lincoln Industrial Electric Pump can operate on 12, 24 or 90 VDC. The pump is primarily designed for railroad lubrication and can be used for centralized lubrication systems such as the Single Line Parallel\*, Single Line Progressive and Two Line systems. Pressure relief valve or pressure switch or both should be included into the system installation. See Illustration 1 for possible installation schematic.

\*Note: Centro-Matic Single Line Parallel system will require an electric operated vent valve. The line pressure has to be vented between lubrication cycles to allow the injector valves to recharge. An electrically operated 2-way solenoid valve is required for this purpose. Consult Lincoln Industrial Technical Services for recommendations. See Figure 2.

The pump is driven by the rotary motion of the electric DC gear motor. Rotary motion is converted to reciprocating motion through an eccentric crank mechanism. The reciprocating action causes the pump cylinder to move up and down. The pump is a positive displacement double acting pump as grease output occurs during both the up and down stroke of the pump.

During the down stroke, the pump cylinder is extended into the grease. Through the combination of shovel action and vacuum generated in the pump cylinder chamber, the grease is forced into the pump cylinder. Simultaneously, grease is discharged through the outlet of the pump. The volume of grease during intake is twice the amount of

# FlowMaster™ Electric Pump



Typical Installation Schematic  
For Single Line Progressive and Two Line systems.

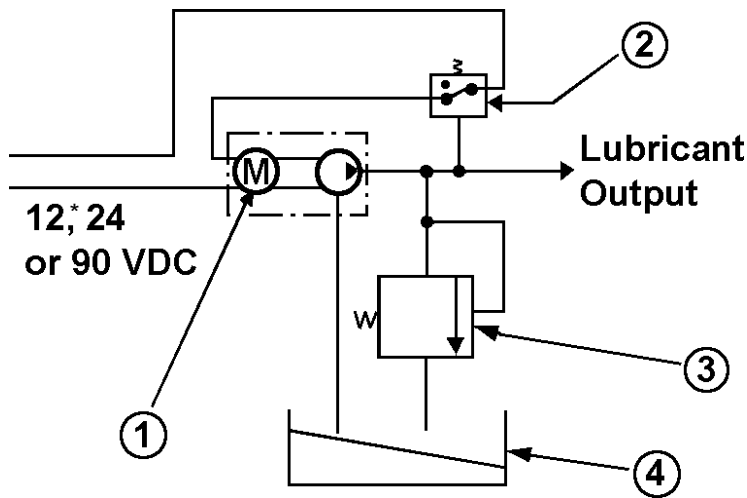

1. Electric Flow Master Pump
2. Pressure Switch
3. Pressure Relief Valve
4. Grease Reservoir

Illustration 1

\* Use #10 wire on 12 Volt pump power wiring

grease output during one cycle. During the upstroke, the inlet check closes, and one half of the grease taken in during the previous stroke is transferred through the outlet check and discharged to the outlet port.

## Appropriate Use

- All pump models are exclusively designed to pump and dispense lubricants using electrical power.
- The maximum specification ratings should not be exceeded.
- Any other use not in accordance with instructions will result in loss of claims for warranty and liability.

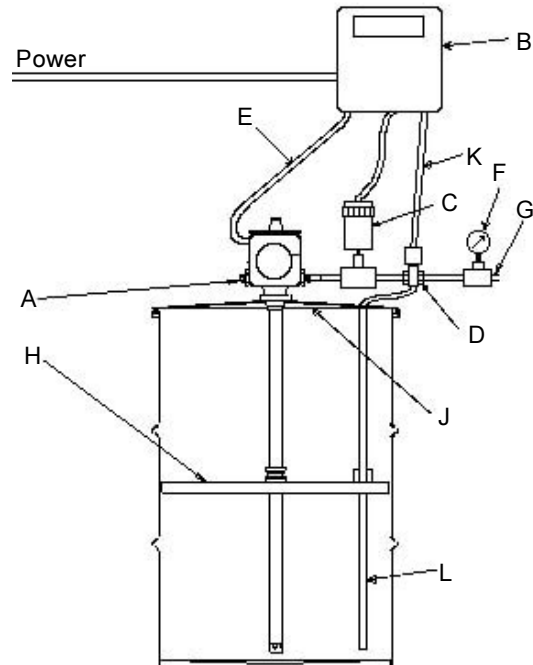

Figure 2

- A - Pump Outlet Plug
- B - Controller/Timer\*
- C - Pressure Switch
- D - Pressure Relief Valve
- E - Wire connections from controller/timer
- F - Pressure Gage
- G - Material Supply Line
- H - Follower Plate (85493 for 400 lb. drum only)
- J - Drum Cover (83115 for 400 lbs.)
- K - Wire connection to Relief (Vent) valve
- L - Vent Tube

\* Controller/Timer should be rated to carry appropriate current per pump performance specifications. External relay can be used with low current controller/timer.



- Housing Cover (30) and the Cover Gasket (31).
3. Remove Retaining Ring (51) and pull the Shovel Plug (50) from the Housing Tube (48).
  4. Remove four Socket Head Screws (37) and separate the Gear Motor (36) from the Pump Housing Adapter (33).
  5. Remove Flat Head Screws (34) and remove Adapter Plate (33) from Housing (39).
  6. Remove Seal (35) from Adapter Plate (33).
  7. Remove two Outlet Pin Nuts (43) from the Pump Housing (39).
  8. Remove the Pump Subassembly (1 through 28) from the Pump Housing (39). Pushing the Subassembly up with a wooden or plastic rod 3/4 O.D. against the Check Seat Housing (28) is helpful.
  9. Remove the Housing Tube (48) from the Pump Housing (39) by inserting a 3/4 rod through the inlet holes at the bottom of the Housing Tube (48) and unscrewing it.
  10. Remove the Bronze Bearing (44), the O-Ring (45), and the Backup Washer (46) from the Housing Tube (48).
  11. Remove the Crankrod Assembly (1 through 8) from the pump by unscrewing the Button Head Screws (12) and then pulling out the Wrist Pin Bushings (13).
  12. Remove the Check Seat Housing (28) from the Reciprocating Tube (21). There is a 3/8 Allen Head socket in the throat of the Check Seat Housing (28) to facilitate removal.
  13. Unscrew the Wrist Pin Anchor (14) from the Reciprocating Tube (21) and pull the Plunger Assembly (9 through 20) from the Tube.
  14. Using a 1/2" wooden or plastic rod, push the Cup Seal (22) and the Pump Cylinder (24) from the Reciprocating Tube (21).
  15. Remove the Pump Plunger (20) from the Plunger Link Rod (17). A Spanner Wrench, which uses the holes in the Pump Plunger, is required.
  16. Unscrew the Plunger Link Rod (17) from the Plunger Tube (11) and slide off the Cup Seal (16), the Backup Washer (15) and the Wrist Pin Anchor (14).
  17. Unscrew the Plunger Tube (11) from the Outlet Pin (9).
  18. To dismantle the Crankrod Assembly (1 through 8), remove Flat Head Screws (1) and the Counter Weights (2).
  19. Remove the large Retaining Rings (6) and press the Crank Eccentric (7) out of the Ball Bearing (8). Be sure to support the Ball Bearing (8) on the inner race.
- Procedure except for the following:
4. Install parts (22) through (28) into the Reciprocating Tube (21) after the plunger assembly (9 through 20) is installed.
  5. Install the Pump Subassembly (1 through 28) into the pump Housing (39) before tightening the Housing Tube (48) to the Pump Housing (39). Be sure the Reciprocating Tube (21) is inserted through both bushings before tightening the Housing Tube (48).
  6. Refill crank case with oil and install cover (30).
  7. Use loctite 242 (or similar product) medium strength thread lock on all torqued threaded connections. Extreme care must be exercised to prevent excess compound from flowing into critical areas such as clearance fits and ball check. Allow a minimum of 30 minutes cure time before operating the pump.
  8. Torque Specifications:
    - A. Plunger Tube (11) to Outlet Pin (9) - 100 to 110 In.-Lbs.
    - B. Button Head Screws (12) to Wrist Pin Anchor (14) 100 to 110 In.-Lbs.
    - C. Plunger Tube (11) to Plunger Link Rod (17) - 100 to 110 In.-Lbs.
    - D. Plunger Link Rod (17) to Pump Plunger (20) - 100 to 110 In.-Lbs.
    - E. Flat Head Screws (1) to Counter Weight (2)© - 100 - 110 In.-Lbs.
    - F. Wrist Pin Anchor (14) to Reciprocating Tube (21) - 20 to 25 Ft.-Lbs.
    - G. Check Seat Housing (28) to Reciprocating Tube (21) - 20 to 25 Ft.-Lbs.
    - H. Outlet Pin Nut (43) to Pump Housing (39) - 30 to 35 Ft.-Lbs.
    - I. Housing Tube (48) to Pump housing (39) - 20 to 25 Ft.-Lbs.
    - © J. Flat Head Screws (134) to pump housing (39) - 50-55 Ft. Lbs.
    - © K. Socket Head Screws (37) to Adaptor Plate (33) - 10-15 Ft.-Lbs.

## Pump Assembly Procedure

1. When the pump is disassembled, replacement of all seals and gaskets is recommended. These parts are included in the 270663 repair kit.
2. In the process of disassembly, examine the following components and replace if excessive wear is indicated: Ball Bearing (8), Crank Eccentric (7), Crankrod (5), Wrist Pin Bushings (13), Plunger Tube (11), Pump Plunger and Upper Check Parts (20, 19 and 18), Pump Cylinder (24), Check Seat Housing and Lower Check Ball (28 and 26), upper Bronze Bushing (44), Housing Tube (48), Shovel Plug (50), and Reciprocating Tube (21).
3. Assembly Procedure is the reverse of the Disassembly

© indicates change.

# FlowMaster™ Electric Pump

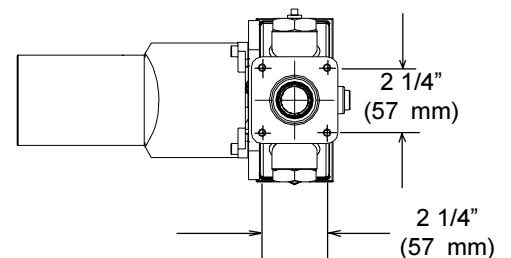
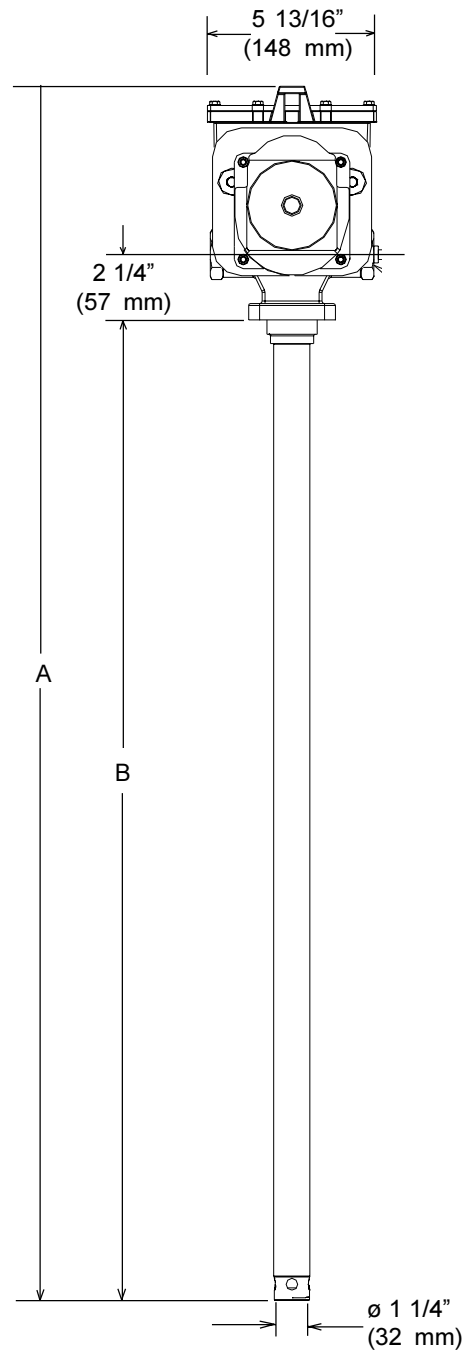
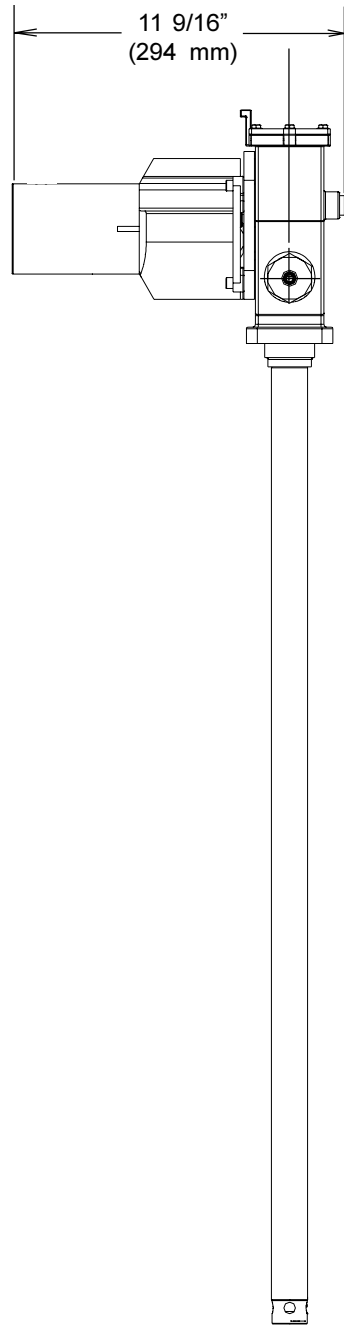

	85578	85579	85580	85582
A	42 (1067 mm)	21 11/16 (551 mm)	21 11/16 (551 mm)	27 1/16" (687 mm)
B	34 (864 mm)	13 5/8 (346 mm)	13 5/8 (346 mm)	18 15/16" (481 mm)

# FlowMaster™ Electric Pump

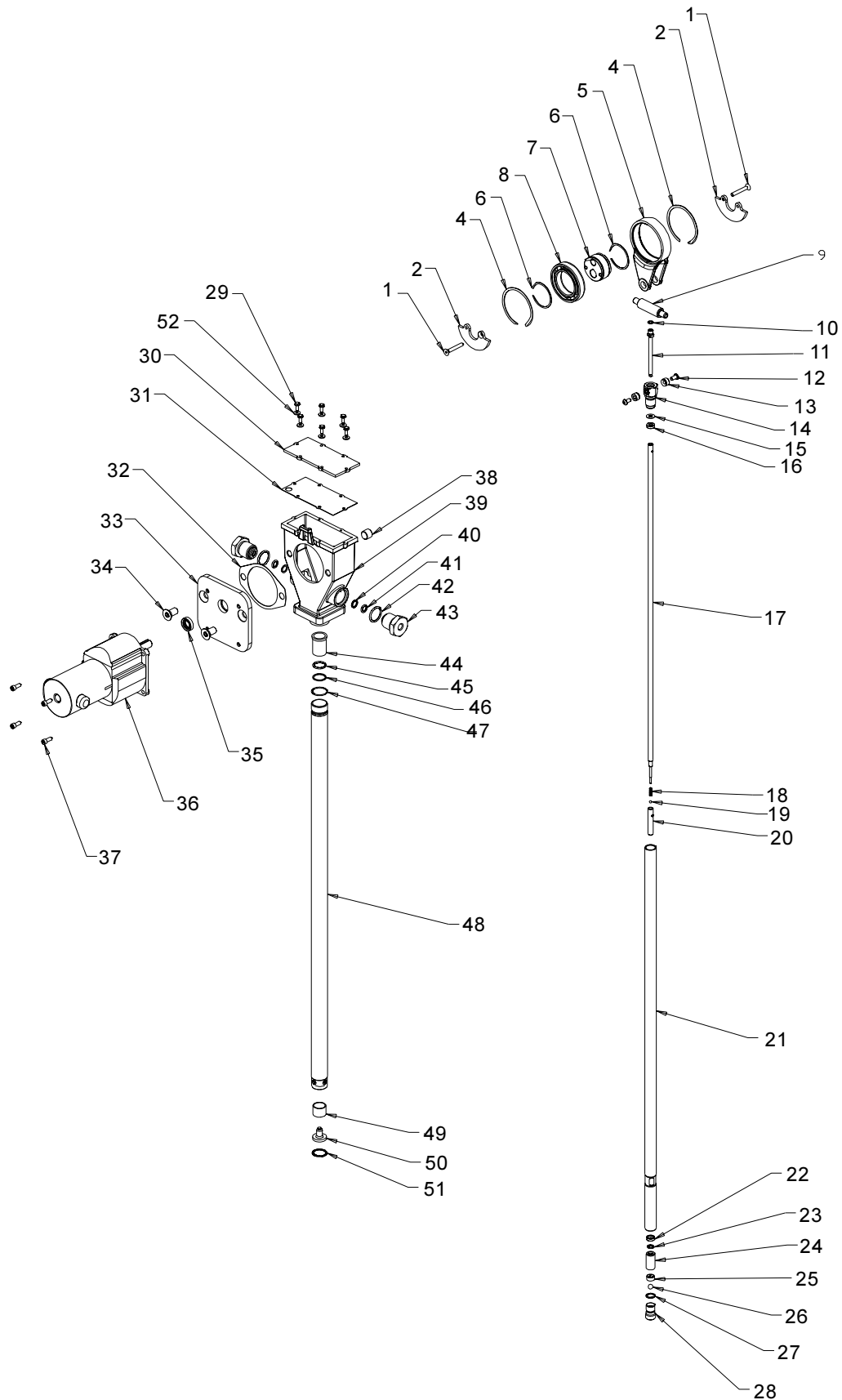

## Repair Parts List (Common to all Models)

Item No.	Qty	Description	All Models	Item No.	Qty	Description	All Models
1	2	Flat Head Screw (1/4 x 1-3/4)	270635	26	1	Ball	66001
				27	1	O-Ring (Nitrile)	*
2	2	Counter Weight©	272197©	28	1	Check Seat	270664
4	2	Retaining Ring	270609	29	6	Self-Threading Screw (8 x 1/2)	270633
5	1	Crankrod	270665				
6	2	Retaining Ring	270608	30	1	Housing Cover	270629
7	1	Crank Eccentric	270666	31	1	Cover Gasket (Nitrile)	*
8	1	Ball Bearing	270607				
9	1	Outlet Pin	270670	32	1	Motor Gasket	*
10	1	O-Ring (Nitrile)	*	33	1	Adaptor Plate	252851
11	1	Plunger Tube	270667	34	2	Flathead Screws	252854
12	2	Button Head Screw (1/4 x 1/2)	270634	35	1	Seal	252864
				36	1	Gear motor	See Chart Below
13	2	Wrist Pin Bushing	270668	37	4	Cap Screws	252853
14	1	Wrist Pin Anchor	270669	38	1	Pipe Plug (3/8 NPTF)	67417
15	1	Backup Washer	*	39	1	Pump Housing	270673
16	1	Cup Seal (Polyurethane)	*	40	2	Backup Ring (Polyurethane)	*
				41	2	O-Ring (Polyurethane)	*
17	1	Plunger Link Rod	See Chart Below	42	2	O-Ring (Nitrile)	*
18	1	Spring	270616	43	2	Outlet Pin Nut	270619
19	1	Ball	66010	44	1	Bronze Bushing	270674
20	1	Pump Plunger	270671	45	1	O-Ring (Polyurethane)	*
21	1	Reciprocating Tube	See Chart Below	46	1	Back-up Washer	*
22	1	Cup Seal (Polyurethane)	*	47	1	O-Ring (Nitrile)	*
				48	1	Housing Tube	See Chart Below
23	1	O-Ring (Polyurethane)	*	49	1	Housing Bushing	270637
				50	1	Shovel Plug	270707
24	1	Pump Cylinder	270672	51	1	Retaining Ring	270705
25	1	Ball Cage	270675	52©	6	Gasket	252986

\* Included in 270663 Soft Parts Kit.

## Repair Parts List (Non-common items)

Item No.	Qty.	Description	Model 85578, 400lbs.	Model 85579, 5 Gal.	Model 85580, 5 Gal.	Model 85582, 60 Lb.
17	1	Plunger Link Rod	270645	270641	270641	270614
21	1	Reciprocating Tube	270646	270642	270642	270617
48	1	Housing Tube	270661	270662	270662	270628
36	1	Gear Motor	252852	252852	252977	252975

© indicates change.



## Troubleshooting

Condition	Possible Cause	Corrective Action
Pump does not run.	No power to motor.	Check power circuit.
	Power is applied to motor. - Pump is stalled due to grease backpressure	Check vent valve in system.
	Pump is seized or damaged.	Dismantle the pump and repair defective or seized component. See disassembly and assembly procedure.
Pump speeds up or runs erratically.	Low level of grease or reservoir is empty.	Refill reservoir.
	Follower plate is stuck and separated from grease.	Check follower plate and container for damage.
	Pump piston or checks are worn.	Disassemble the pump and repair.
Pump runs, but output is low.	Inlet voltage too low.	Increase voltage.
	Faulty inlet (25, 26, 27) or discharge check valve (18, 19, 20).	Replace faulty components.
Weepage from housing cover 30.	Cup seal (16) or O-Ring (11) wore out.	Check the seals and replace if necessary.
Pump becomes noisy.	No crank case oil.	Add crank case oil. Remove Pipe Plug (38) from Pump Housing (39). Oil level should be at the bottom of the Pipe Plug opening. Add 10W30 motor oil until the crankcase is full.
	Worn wrist pin bushing 13.	Check the bushings and replace if necessary.

*Lincoln Industrial*  
*One Lincoln Way*  
*St. Louis, MO 63120-1578*  
*(+1) 314 679 4200*  
*[www.lincolnindustrial.com](http://www.lincolnindustrial.com)*

*Lincoln GmbH*  
*69190 Walldorf*  
*Heinrich-Hertz Strasse 2-8*  
*(+49) 6227 33-0*

*Lincoln Industrial*  
*25 International Business Park*  
*#01-68 German Centre*  
*Singapore 609916*  
*(+65) 562-7960*