**FlowMaster™ Rotary Driven Hydraulic Pump
Model 85244
Series "A"**

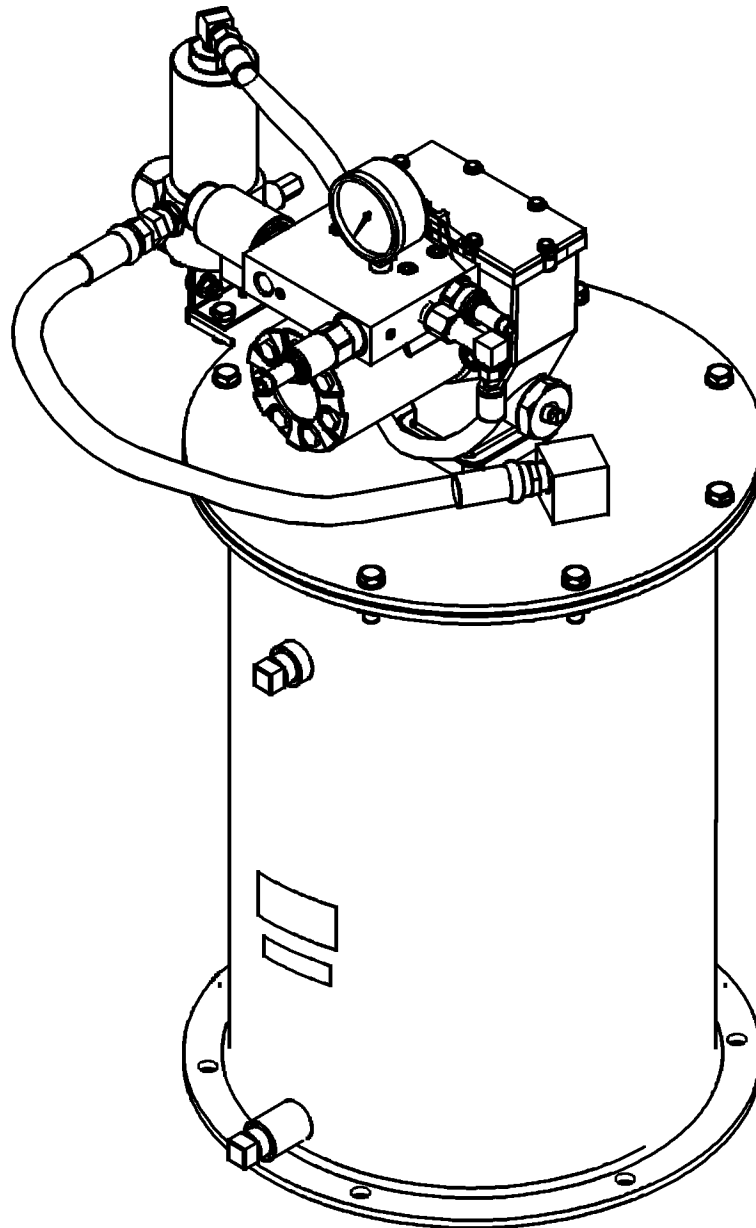

TABLE OF CONTENTS

	Page
Safety.....	2
Specifications.....	2
Description.....	2
System Operation.....	2
Installing the Pump.....	3
Putting Pump into Operation.....	3
Maintenance & Repair.....	3
Dimensions.....	6
Repair Parts List.....	7
Troubleshooting.....	8



Do not exceed 3,500 PSIG (241 bar) maximum supply inlet hydraulic pressure or 3500 PSIG (241 bar) maximum outlet pressure. Exceeding the rated pressures may result in damage to system components and personal injury.

DESCRIPTION

General Description

Model 85244 is a pumping unit designed to operate a Centro-Matic® lubrication system. The units include a vent valve to relieve the line pressure to recharge the injectors. FlowMaster™ Rotary Driven Hydraulic Pump includes pressure reducing valve, flow control valve and solenoid operated (24 VDC) “On” and “Off” valve. A 24 volt DC solenoid valve with a manual override is standard on model 85244 and is an option on other models.©

The FlowMaster pump is fully automatic when used with Model 85530 Controller and a pressure switch. The FlowMaster pump is double acting, dispensing lubricant on both the “Up” and “Down” strokes. This unit is designed to be used with SL-1, SL-11, SL-32 and SL33 series injectors or a combination of these.

Appropriate Use

- The pump on this unit is exclusively designed to pump and dispense lubricants using hydraulic power only.
- The maximum specification ratings should not be exceeded.
- Any other use not in accordance with instructions will result in loss of claims for warranty and liability.

SAFETY

Read and carefully observe these operating instructions before unpacking and operating the pump! The pump must be operated, maintained and repaired exclusively by persons familiar with the operating instructions. Local safety regulations regarding installation, operation and maintenance must be followed.

Operate this pump only after safety instructions and this service manual are fully understood.



This symbol indicates a potentially hazardous situation which, if not avoided, could result in death or serious injury. Please refer to the 85481 operation manual, section C8, page 269, series “B” for all other safety considerations.

PRODUCT SPECIFICATIONS

Supply inlet hydraulic pressure, maximum, PSIG (bar) -	3,500 (241)
Operating working hydraulic pressure, PSIG (bar) -	300 to 450 (21 to 31).
Max. output pressure, PSIG (bar) -	3500 (241)
Hydraulic inlet flow, GPM (l/min) -	Up to 7 (27)
Pump ratio with manifold -	9:1 at low inlet pressure (300 to 350 PSI [21 to 24 bar]) and low inlet flow (below 2 gpm [7.5 lpm]) Pump ratio approaches 11.0:1 ratio at higher inlet pressure and flow.
Ambient oper. temp. °F (°C) -	-20 to +150 (-29 to +66)
Operating voltage, VDC -	24
Hydraulic inlet port, In -	SAE 4
Tank return port, In -	SAE 6
Maximum hydraulic fluid temp., °F (°C) -	250 (121)
Weight, Lbs (Kg) -	101 (46)
Container capacity , Lbs (Kg) -	90 (41)

SYSTEM OPERATION

Operation with Model 85530 System Controller

When Model 85530 times out, it will initiate a lube cycle. The solenoid is energized to deliver hydraulic pressure to the pump and vent valve. Pump begins dispensing lubricant through injectors to the bearings.

When all bearings have received lubricant, pressure rises in the system to actuate the pressure switch. When pressure switch actuates, the control is reset to de-energize the solenoid valve cutting off hydraulic oil pressure to the pump and vent valve. Pump stops, pressure vents and pressure switch de-actuates. Control begins timing toward next lube event.

INSTALLING THE PUMP

Place the unit in the approximate location making sure that electric and hydraulic power connections are accessible. Mark center locations of the six holes at the bottom of the reservoir. Then drill six 1/2" (13 mm) holes. The use of 7/16" (11 mm) bolts will offer some flexibility in securing the reservoir to the equipment.

Lubricant outlet of pump should be connected to system with suitable hose capable of 3,500 PSI (241 bar) working pressure. Hydraulic inlet connection should be made with at least 3/8" (9 mm) I. D. hose capable of at least 3,000 PSI (207 bar) operating pressure. Hydraulic return to tank connection line should be 3/4" (19 mm) I. D. hose or pipe.

Please refer to the 85481 operation manual, section C8, page 269, series "B" for setting the pump pressure and flow control.

PUTTING PUMP INTO OPERATION

Filling Reservoir

- To bulk fill the reservoir, remove the lower and upper pipe plugs from the side of the reservoir (see Figure 4). Attach the appropriate bulk-filling pump to the lower inlet (3/4 NPT). Fill reservoir until grease appears at the top 1/2 NPT vent high level port. Remove the bulk-filling pump. Replace both pipe plugs.
- To use the reservoir with a five-gallon pail of lubricant, first remove the six bolts that secure the lid. Remove the entire assembly of lid, pump and vent valve. Using pipe wrench or vice grips, remove the filler nipple extension (25) (Figure 4) attached inside the reservoir at the 3/4 NPT inlet nipple. Insert opened pail of lubricant and reattach lid and pump assembly.

Note: If five gallon pail lubrication is to be used, then the optional wing screws (28) should be used in place of the hex bolt (29).



When filling the reservoir, caution should be used as extreme pressure can cause damage to the reservoir or serious personal injury.

MAINTENANCE & REPAIR

General Maintenance

- Keep area around pump clean. Clean off filling port area prior to filling reservoir. Clean area around filler after filling as lubricants will attract dirt.
- Keep lubricants clean and free of dirt and debris.
- When replacing grease pails be especially careful to prevent any foreign matter from entering the grease pail or contaminating the grease, as it adheres to the pump.

In Case of System Malfunction (See Trouble Shooting Chart Page 8)

- Use the **Trouble Shooting Charts** to determine where to look if problems occur.
- See the sections below for replacement and repair of specific areas of the check valve, vent valve or safety unloader valve.
- Each part is identified with a number keyed to the matching part on the illustrated views.
- General recommendations of tools required are also specified in each step.
- Pay particular attention to the **Warning** statements to prevent personal injury and possible damage to pump components.

Outlet Check Service (See Figures 1, 2, 5 & 6, Pages 5 & 6)

The pump will not build up sufficient lubricant pressure if the outlet check (36) is fouled. Foreign material may lodge beneath the Check Ball (15) or between check disc (11) and the seat of bushing assembly (12). Sealing surfaces of the seat must form a perfect seal. Clean parts or replace if pitted, worn or scored.

1. Turn off and disconnect the hydraulic and electric power supply to the pump assembly.
2. Standard tools required are a bench mounted vice, a set of open end wrenches ranging from 7/16" to 1-1/2", a large 24" (600 mm) adjustable wrench and a smaller 10" (254 mm) adjustable wrench.
3. Remove bolts and lock washers (41 & 42).
4. Loosen adapter union (37). Set vent valve assembly to the side.
5. Remove entire outlet check assembly (36) by loosening adapter (35) from pump outlet.
6. Remove adapter (35) from outlet check assembly (36).
7. Remove outlet connector (16) from bushing (12).
8. Remove ball check seat (13) from outlet connector (16).
9. Inspect all check components (11, 12, 13, 15) for presence of foreign material, scoring and or other damage, which may cause internal leakage. Replace components if damage is found.

10. If foreign material is present, clean components and reassemble. Be sure to always replace gaskets (10) & (14) whenever vent valve is disassembled. Reverse the above procedure to reassemble. Torque check assembly to 100 ft.-lbs. (13.5 N-M).

Vent Valve Service (See Figures 3, 5 & 68 Pages 5 & 6)

1. Turn off and disconnect the hydraulic and electrical power supply to the pump assembly.
2. Standard tools required are a bench mounted vice, a set of open end wrenches ranging from 7/16" to 1-1/2", a large 24" (600 mm) adjustable wrench and a smaller 10" (254 mm) adjustable wrench.
3. Loosen Adapter Union (37) and Vent Hose (8).
4. Remove bolts and lock washers (41 & 42). Remove vent valve.
5. Hold base of vent valve in vice to remove elbows (6 & 9). Turn vent valve in vice so that vice jaws are gripping flats machined on base of vent valve.
6. Remove hydraulic cylinder (17). Remove piston and packing (18) from cylinder. If oil leakage was evident from side of hydraulic cylinder then replace packing.
7. Remove packing assembly (20). If grease leakage was evident from side of hydraulic cylinder, then replace packing assembly.
8. Inspect needle (19) and valve seat (21). If foreign matter is lodged and is keeping the needle from sealing in valve seat, clean and inspect for damage. If seat appears damaged by nicks, grooves or scouring it should be replaced. Remove valve seat (21) from valve body (23) by

placing a 3/4" open end wrench onto the flats and loosening the seat. The use of an adjustable wrench in place of the open end wrench may be necessary due to the accessibility of the seat.

9. Replace the valve seat (21) if damaged. Also be sure to remove and replace the gasket (22) below the seat.
10. Reassembly is the reverse of the above procedure. Needle (19) and hydraulic cylinder (17) inside diameter should be coated with oil or grease to assist in assembly.
11. Upon reassembly tighten valve seat (21) into body (23) using 25 ft.-lbs. (39 N-M). Tighten hydraulic cylinder (17) onto valve body (23) using 100 ft.-lbs. (135 N-M)

Safety Unloader Valve (See Figure 1 Page 5)

Safety unloader valve (5) is not serviceable and should be replaced if malfunction is apparent. Upon reassembly, tighten to 10 ft.-lbs. (13.5 N-M).

The Safety Unloader (5) is set to open at 3,750 to 4,250 PSI lubricant pressure. If pressure Switch fails to operate and shut off hydraulic supply to pump, the Safety Unloader will open at approximately 4,000 PSI to relieve lubricant supply line pressure (Safety Unloader is preset and cannot be adjusted.)

Bare Pump Assembly (See Figure 4 Page 5)

Please refer to the Operation Manual (C8, Page 269 series) for the bare pump assembly (24).

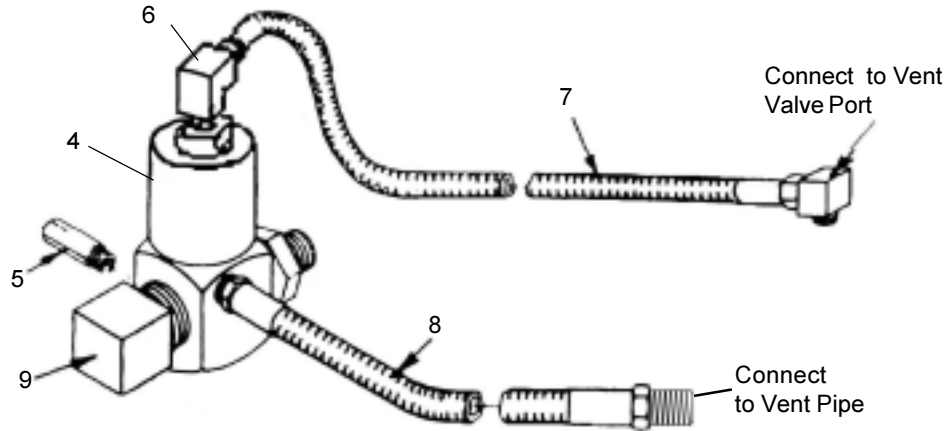

Vent Assembly
Figure 1

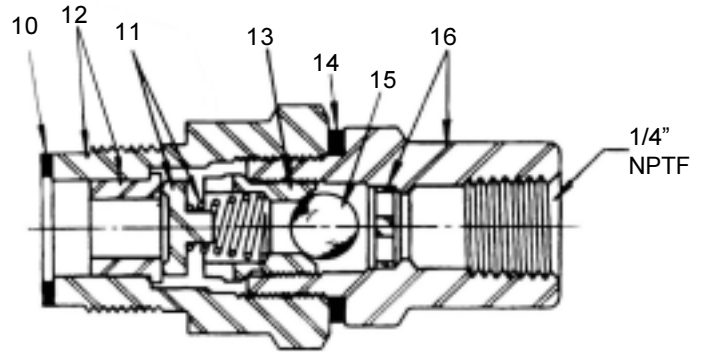

Outlet Check Assembly (47)
Figure 2

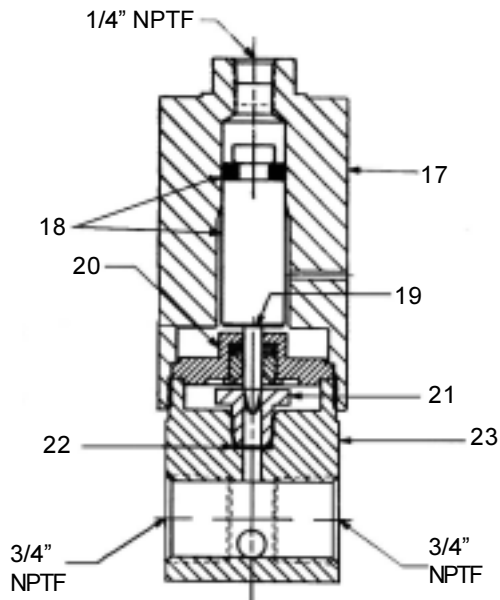

Vent Valve (10)
Figure 3

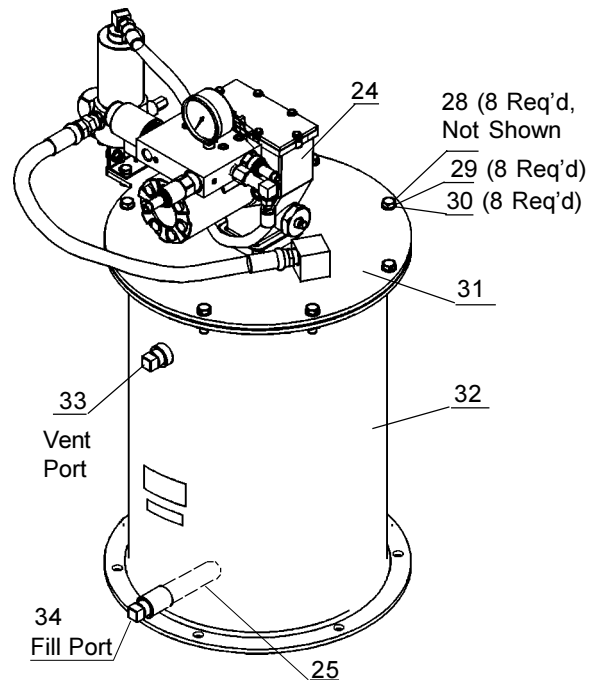

Figure 4

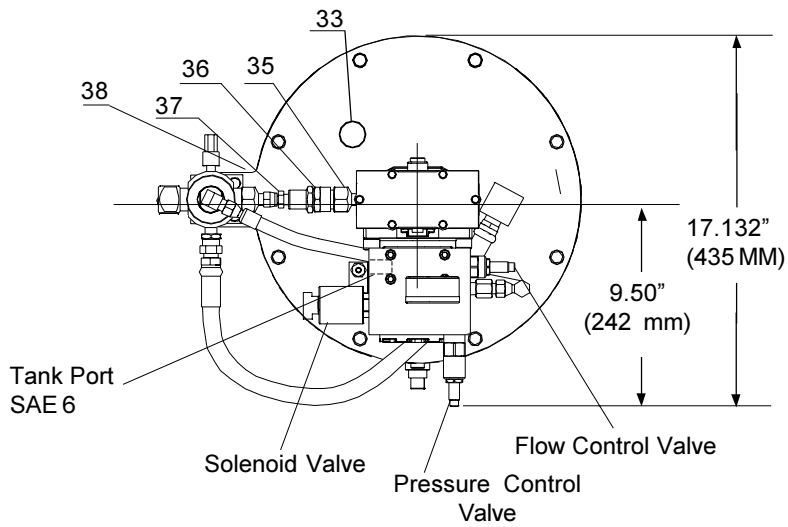

Figure 5

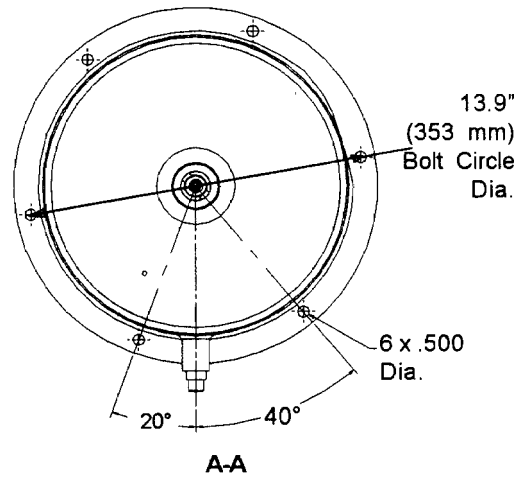
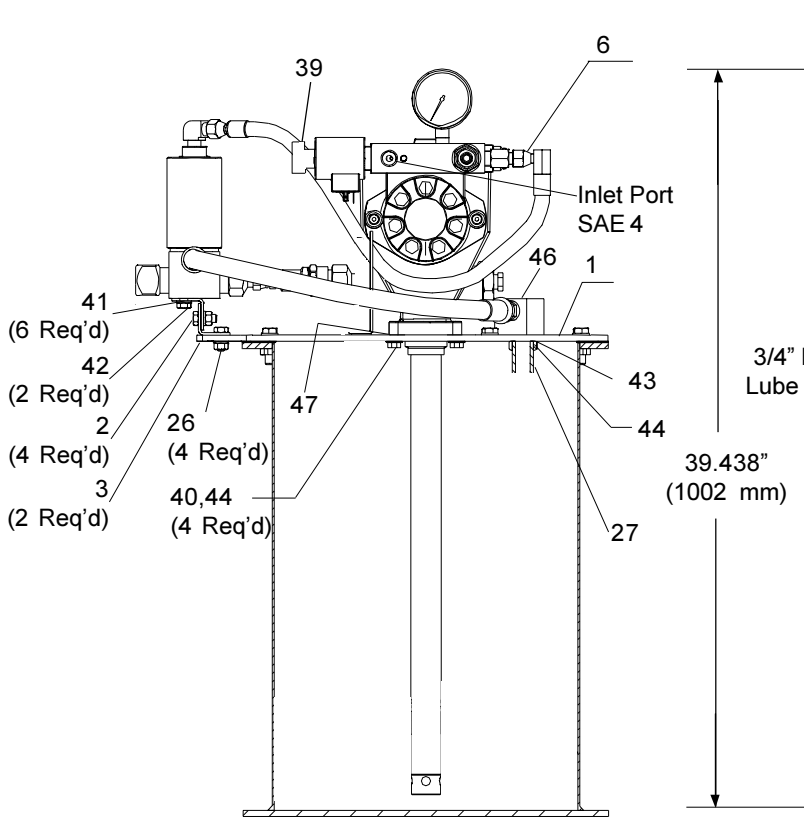
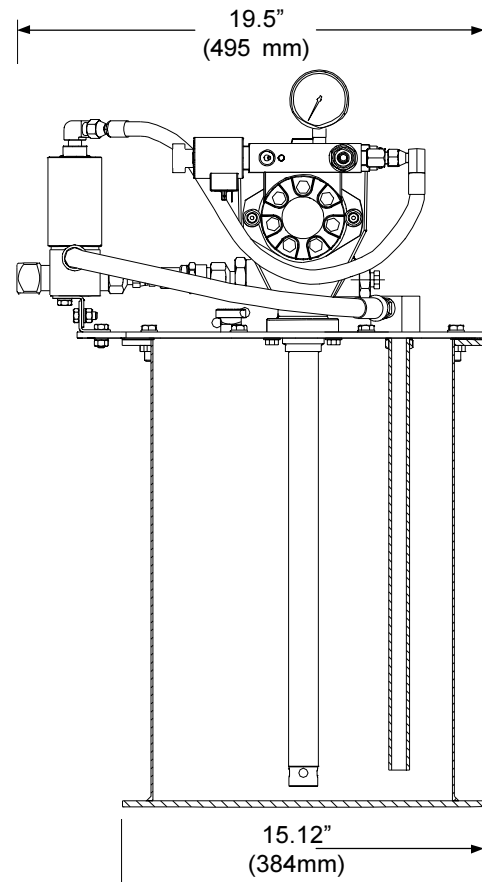

Figure 8



Model 86258
Figure 6



Model 85487
Figure 7

SERVICE PARTS

Item No.	Qty.	Description	Model	Item No.	Qty.	Description	Model
1	1	Drum Cover	241085	25	1	Extension Tube	249356
2	4	Bolts	50016	26	4	Hex Nut	51026
3	2	Bracket	270723	27	1	Vent pipe	272171
4	1	Vent Valve Assembly	84980	28	8	Wing Screws (not shown)	252727
5	1	Safety Unloader Ass'y	*90942	29	8	Bolt	50015
6	1	Elbow	20012	30	8	Lock Washer	66220
7	1	Hydraulic Hose	©271598	31	1	Gasket	*249355
8	1	Vent Hose	270726	32	1	Container Assembly	270923
9	1	Elbow	10160	33	2	Pipe Plug, Vent	67117
10	1	Gasket	*31029	34	1	Pipe Plug, Fill	67224
11	1	Pump Check Disc Ass'y	+*80206	35	1	Adapter	12213
12	1	Outlet Check Bushing	+*90204	36	1	Outlet Check Assembly	81938
13	1	Ball Check Seat	*10313	37	1	Adapter Union	66645
14	1	Gasket	*31001	38	1	Reducer Nipple	14727
15	1	Check ball (3/8" Dia.)	*66001	39	1	Manual Override	272112
16	1	Outlet Connector	+90860	40	4	Screw	50169
17	1	Hydraulic Cylinder	241807	41	6	Lock Washer	66246
18	1	Piston	+*244673	42	2	Bolt	50034
19	1	Needle	*14722	43	1	Gasket	*31010
20	1	Viton Packing Ass'y	+*239330	44	1	Nut	12538
21	1	Valve Seat	*14723	45	1	Retaining Ring	*68888
22	1	Check Seat gasket	*31047	46	1	Elbow	249533
23	1	Valve Body	239336	47	1	Gasket	33152
24	1	Bare Pump Assembly	271616	48	12	Lockwasher	66186

© Indicates change

* Suggested service replacement component
 + Sold as an assembly. Individual parts not available.

* Suggested service replacement components

MODELS 85244 TROUBLESHOOTING

CONDITION	POSSIBLE CAUSE	CORRECTIVE ACTION
Pump does not operate.	No hydraulic power to pump.	Turn on or connect hydraulic supply to pump.
	No pressure on gauge: - Closed Supply line shut off valve. - No power to solenoid valve. - Faulty Solenoid. - Pressure Reducing Valve is set too low. - Insufficient Hydraulic Fluid supply.	Open shut-off valve. Correct electrical fault. Replace solenoid. Reset Pressure Reducing Valve. Check hydraulic supply for proper pressure and flow.
	Pressure is shown on gauge on pump manifold. - Closed Fluid outlet line.	Check outlet line and clear obstructions.
	- Flow Control Valve is fully closed. - Pump is stalled due to grease backpressure.	Readjust flow control valve to 1 turn open. Check vent valve in system.
	Pump is seized or damaged.	Dismantle the pump and repair defective or seized component. See pump service page.
Pump runs excessively.	Pump tube malfunction.	Refer to pump service page.
	Outlet check damage or contamination.	Repair check or remove contamination.
	Vent valve damage or contamination.	Repair vent valve or remove contamination.
	System component leaking.	Repair leaks.
	Vent valve not relieving proper pressure to keep it closed.	Orifice fitting plugged.
	Injector bypassing.	Repair injectors.
Pump speeds up or runs erratically.	Low level of grease or reservoir is empty.	Refill reservoir.
	Pump piston or checks are worn.	Refer to pump service sheet.
Pump runs, but output is low.	Insufficient hydraulic fluid supply.	Check hydraulic supply and adjust flow.
	Inlet pressure too low.	Increase pressure at pressure control valve.
	Faulty inlet or discharge check valve in pump.	Replace faulty components. See pump service page.
Lubricant leaking from safety unloader valve.	Pressure of system set too high.	Adjust pressure switch setting.
	Safety unloader damaged or contaminated.	Replace safety unloader.
Lubricant leaking from weep hole in vent valve.	Vent valve lubricant seal damaged.	Replace lubricant seal.

Americas:
One Lincoln Way
St. Louis, MO 63120-1578
USA
Phone +1.314.679.4200
Fax +1.800.424.5359

Europe/Africa:
Heinrich-Hertz-Str 2-8
D-69183 Walldorf
Germany
Phone +49.6227.33.0
Fax +49.6227.33.259

Asia/Pacific:
25 Int'l Business Park
#01-65 German Centre
Singapore 609916
Phone +65.562.7960
Fax +65.562.9967



© Copyright 1999
Printed in USA
Web site:
www.lincolnindustrial.com