

**Model 85465 (Series "A")  
Air Operated Pump  
w/Ultrasonic Sensor**

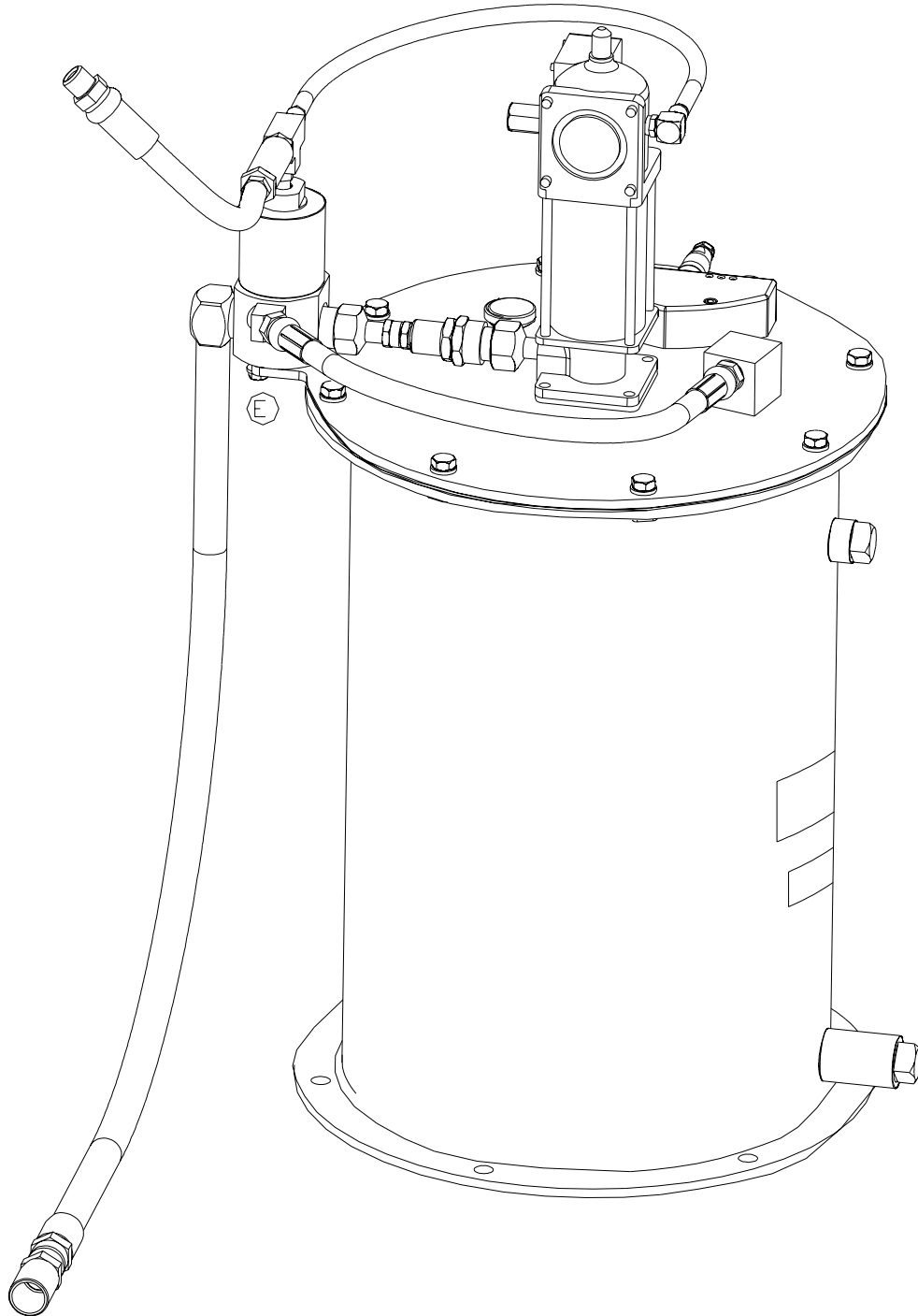

## Table of Contents

	Page
Safety.....	2
Specifications.....	2
Description.....	2
Pump Operation.....	2
Installing the Pump.....	2
Putting Pump into Operation.....	3
Maintenance and Repair.....	3
Dimensions.....	6
Repair Parts List.....	7
Troubleshooting.....	8

## SAFETY

Read and carefully observe these operating instructions before unpacking and operating the pump! The pump must be operated, maintained and repaired exclusively by persons familiar with the operating instructions. Local safety regulations regarding installation, operation and maintenance must be followed.

Operate this pump only after safety instructions and this service manual are fully understood.



This symbol identifies the potential for a hazardous situation. If this warning is not followed, a serious injury could occur.

Please refer to the following service page for the Model 83513 pump for all other safety considerations:

83513 Pump - Form Number 10L083513000J0  
85209 Control - Section C8, Page 262 Series

## PRODUCT SPECIFICATIONS

Pump Ratio:	<b>50:1</b>
Output Per Cycle	<b>0.55 in<sup>3</sup> (9 cc)</b>
Output Per Minute	<b>30 in<sup>3</sup> (492 cc)</b>
Pump Air Supply Pressure	<b>50 to 70 psi (3.4 to 4.8 bar)</b>
Operating Line Pressure	<b>2500 psi Normal (172 bar)</b> <b>3500 psi Maximum (241 bar)</b>
Container Capacity	<b>60 Lbs. Bulk (27 kg)</b>
Air Consumption	<b>4.3 CFM (120 l/min.)</b>
Operating Temp. Range	<b>-10° F to 140° F</b> <b>(-23° C to 60° C)</b>
Weight	<b>68 lbs. (31 kg)</b>

## DESCRIPTION

### General Description

The Model 85465 is a pumping unit designed to operate centralized lubrication systems. It has a high volume output, delivering thirty cubic inches of lubricant per minute at typical Centro-Matic® pressures. It is fully automatic when used with Model 85209 Control. Pump is double acting, dispensing lubricant on both the UP and DOWN strokes. These units are designed to be used with SL-1, SL-11, SL-32 and SL-33 series injectors or a combination of these. The pump has a combination follower and Ultrasonic Sensor which work in unison to indicate low lubricant levels.

### Appropriate Use

- The pumps on these units are exclusively designed to pump and dispense lubricants using compressed air only.
- The maximum specification ratings should not be exceeded.
- Any other use not in accordance with instructions will result in loss of claims for warranty and liability.

## PUMP OPERATION

### Operation of 85209 with Model 85530 System Controller

When Model 85530 times out, it will initiate a lube cycle. The air solenoid is energized to deliver air to the pump and air to the vent valve. Pump begins dispensing lubricant through injectors to the bearings.

When all bearings have received lubricant, pressure rises in the system to actuate the pressure switch. When pressure switch actuates, the control is reset to de-energize the solenoid valve cutting off air to the pump and vent valve. Pump stops, pressure vents and pressure switch de-actuates. Control begins timing toward next lube event.

## INSTALLING THE PUMP

Place the unit in the approximate location making sure that grease and air connections are accessible. Mark center locations of the six holes at the bottom of the reservoir. Then drill six 1/2" holes. The use of 7/16" bolts will offer some flexibility in securing the reservoir to the equipment.

Lubricant outlet of pump should be connected to system with suitable hose capable of 3,500 PSI working pressure. Air line connection should be made with at least 1/4" I. D. hose capable of at least 100 PSI operating pressure.

## Putting Pump into Operation

### Filling Reservoir

- To bulk fill the reservoir, remove the lower and upper pipe plugs from the side of the reservoir. Attach the appropriate bulk-filling pump to the lower inlet (3/4 NPT). Fill reservoir until grease appears at the top 1/2 NPT high level port. Remove the bulk-filling pump. Replace both pipe plugs.
- To fill the reservoir using a five-gallon pail of lubricant, first remove the six bolts that secure the lid. Remove the entire assembly of lid, pump and vent valve. Using pipe wrench or vice grips, remove the filler nipple extension attached inside the reservoir at the 3/4 MPT inlet nipple. Insert opened pail of lubricant and reattach lid and pump assembly. **Note:** The follower cannot be used with pail.

**Note:** If pail lubrication is to be used, then the optional wing screws (69) should be used in place of the hex bolt (40). When filling the reservoir, caution should be used as extreme pressure can cause damage to the reservoir or serious personal injury.

## MAINTENANCE & REPAIR

### General Maintenance

- Good housekeeping will go a long way in keeping a lubrication system running without problems for many



years of use.

- Keep area around pump clean. Clean off filling area prior to filling reservoir. Clean area around filler after filling as lubricants will attract dirt.
- Keep lubricants clean and free of dirt and debris.
- When replacing grease pails be especially careful to prevent any foreign matter from entering the grease pail or contaminating the grease, as it adheres to the pump.

### In Case of Trouble

#### (See Trouble Shooting Chart Page 7)

- Use the **Trouble Shooting Charts** to determine where to look if problems occur.
- See the sections below for replacement and repair of specific areas of the check valve, vent valve or safety unloader valve.
- Each part is identified with a number keyed to the matching part on the illustrated views.
- General recommendations of tools required are also specified in each step.
- Pay particular attention to the **Warning** statements to prevent personal injury and possible damage to pump components.

### Outlet Check Service (See Illustration Page 5)

1. Turn off and disconnect the air supply to the pump assembly.
2. Standard tools required are a bench mounted vice, a set of open end wrenches ranging from 7/16 to 1-1/2, a large 24" adjustable wrench and a smaller 10" adjustable wrench.
3. Remove bolts and lockwashers (54 & 55).
4. Loosen union (53) and set vent valve assembly to the side.
5. Remove entire outlet check assembly (52) by loosening adapter (50) from pump outlet.
6. Remove adapter (50) from bushing (22).
7. Remove outlet connector (26) from bushing (22).
8. Remove ball check seat (23) from outlet connector (26).
9. Inspect all check components (21, 22, 23, 25) for presence of foreign material, scoring and or other damage, which may cause internal leakage.
10. If foreign material is present, clean components and reassemble, making sure to replace gaskets (20) & (24). Reverse the above procedure to re-assemble. Torque check assembly to 100 ft-lbs.
11. If check components appear to be scored or damaged replace all components (21, 22, 23, 25) and gaskets (20) & (24) with new ones. Reverse the above procedure to re-assemble. Torque check assembly to 100 ft-lbs.

### Vent Valve Service (See Illustration Page 5)

1. Turn off and disconnect the air supply to the pump assembly.
2. Standard tools required are a bench mounted vice, a set of open end wrenches ranging from 7/16 to 1-1/2, a large 24" adjustable wrench and a smaller 10" adjustable wrench.
3. Remove delivery hose (17). Remove vent hose (14). Remove air hose (7).
4. Remove bolts and lockwashers (54 & 55).
5. Loosen union (53) and remove vent valve.
6. Hold base of vent valve in vice to remove nipple (13) and elbow (15). Turn vent valve in vice so that vice jaws are gripping flats machined on base of vent valve.
7. Remove air cylinder (27). Remove piston (28) and packing (29) from air cylinder. If air leakage was evident from side of air cylinder then replace packing.
8. Remove packing assembly (31). If grease leakage was evident from side of air cylinder, then replace packing assembly.
9. Inspect needle (30) and valve seat (32). If foreign matter is lodged and is keeping the needle from sealing in valve seat, clean and inspect for damage. If seat appears damaged by nicks, grooves or scouring it should be replaced. Remove valve seat (32) from valve body (34) by placing a 3/4" open end wrench onto the flats and loosening the seat. The use of an adjustable wrench over the open end wrench may be necessary due to the accessibility of the seat.
10. Replace the valve seat (32) if damaged. Also be sure to remove and replace the gasket (33) below the seat.

11. Reassembly is the reverse of the above procedure.  
Needle (30) and air cylinder (27) inside diameter should be coated with oil or grease to assist in assembly.
12. Upon reassembly tighten valve seat (32) into body (34) using 25 ft-lbs. Tighten air cylinder (27) onto valve body (34) using 100 ft-lbs.

### **Follower (see Illustration Page 6)**

If follower wiper appears to be damaged or does not wipe the sides of the container effectively service may be necessary.

1. Disconnect air supply from pump.
2. Remove the eight bolts (40) which attach the cover to the reservoir.
3. Lift the entire pump, vent valve and cover assembly out of the reservoir.
4. Now remove the entire follower assembly from the pump tube. After removing the follower assembly from the pump tube wipe off the excess grease which will allow clean access to the eight bolts that must be removed.
5. Loosen and remove the eight nuts (66) on top of the follower.
6. Remove the follower weight (67) and the wiper (65).  
Replace the wiper with a new one.
7. Re-assemble in the reverse of the above procedure making sure that the long carriage bolts are staggered with the small ones and that they extend below the follower per the dimension shown.

### **Safety Unloader Valve (see Illustration Page 5)**

The Safety Unloader (11) is set to open at 3,750 to 4,250 PSI lubricant pressure. If pressure Switch fails to operate and shut off air supply to pump, the Safety Unloader will open at approximately 4,000 PSI to relieve lubricant supply line pressure.

Safety unloader valve is not serviceable and should be replaced if malfunction is apparent. Upon re-assembly, tighten to 10 ft-lbs.

### **Bare Pump Assembly (See Illustration Page 5)**

Please refer to the service page included for the bare pump assembly (35).

### **Ultrasonic Sensor**

Please refer to the service page included for the Ultrasonic Sensor (59).

# CENTRO-MATIC® PUMP, MODEL NO. 85465

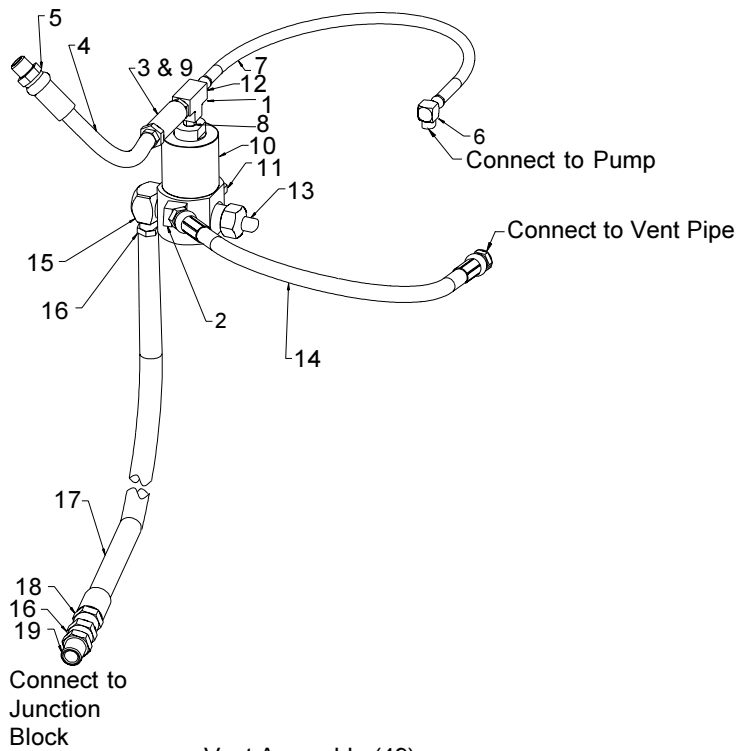

Vent Assembly (49)

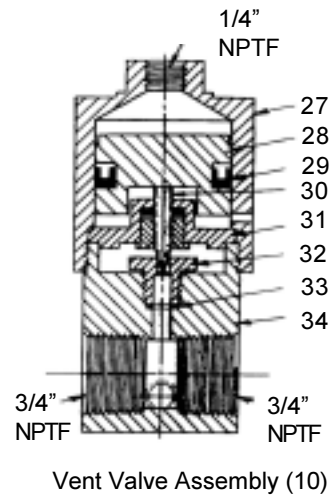

Vent Valve Assembly (10)

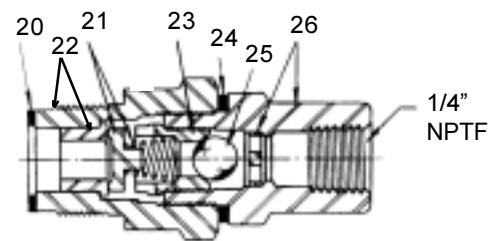

Outlet Check Assembly(52)

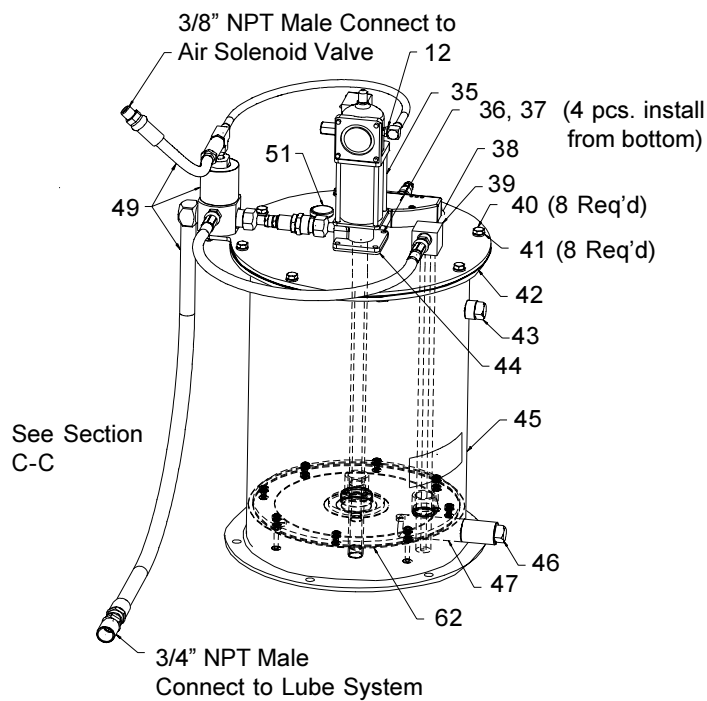

Model 85465

# CENTRO-MATIC® PUMP, MODEL NO. 85465

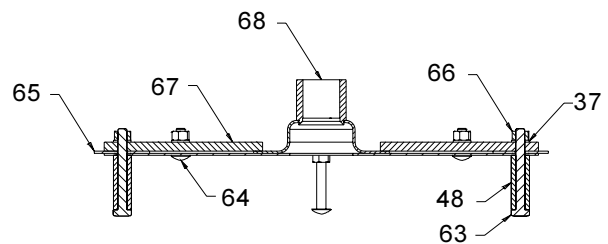
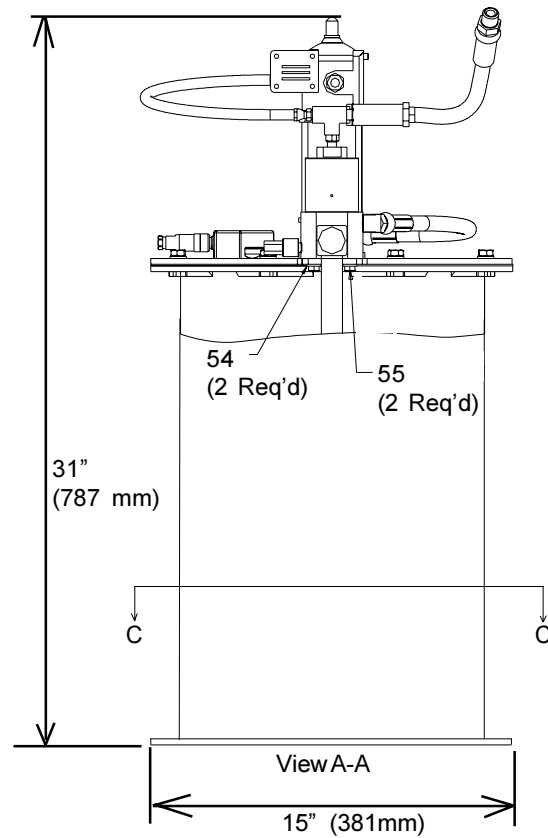
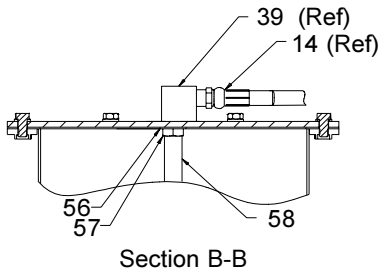
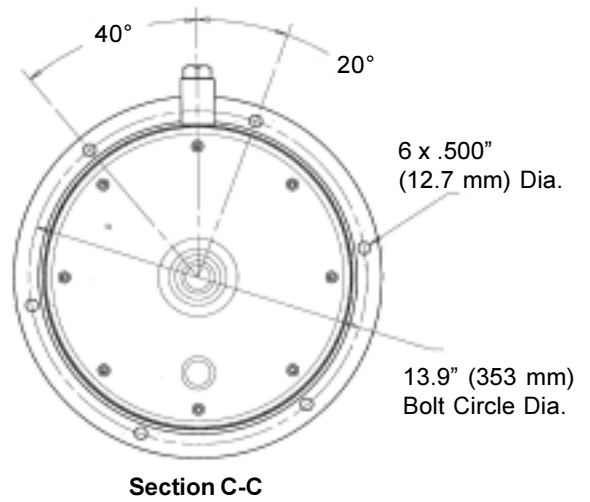
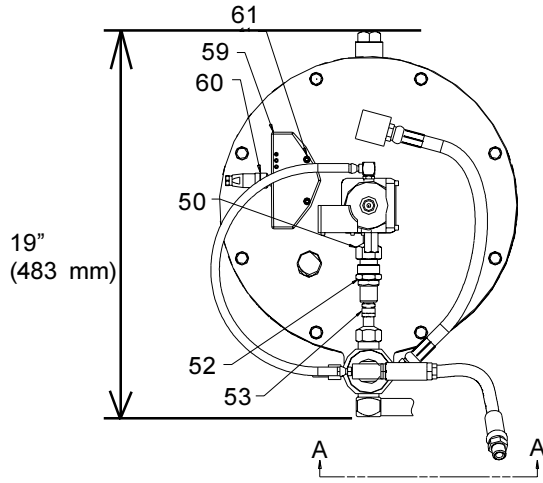

**Follower Assembly (62)**

# CENTRO-MATIC® PUMP, MODEL NO. 85465



## SERVICE PARTS

Item No.	Qty.	Description	Model 84050
1	1	Tee (1/4")	67102
2	1	1/4 Elbow	20038
3	1	Air Coupler	247668
4	1	Air Hose	236737
5	1	Bushing	20011
6	1	Elbow	13129
7	1	Air Hose	237318
8	1	Nipple	10462
9	1	Male Fitting	11659
10	1	Vent Valve Assembly	83948
11	1	Safety Unloader Ass'y	*90942
12	2	Bushing	10461
13	1	Nipple	14727
14	1	Volume Hose	236874
15	1	Elbow	10160
16	2	Nipple	11197
17	1	Delivery Hose	236607
18	1	Adapter Union	66883
19	1	Bushing	12018
20	1	Gasket	*31029
21	1	Pump Check Disc Ass'y	+*80206
22	1	Outlet Check Bushing	+*90204
23	1	Ball Check Seat	*10313
24	1	Gasket	*31001
25	1	Steel ball (3/8" Dia.)	*66001
26	1	Outlet Connector	+90860
27	1	Air Cylinder	14720
28	1	Piston	14721
29	1	Packing (Nitrile)	*34229
30	1	Needle	*14722
31	1	Viton Packing Ass'y	+*239330
32	1	Valve Seat	*14723
33	1	Check Seat Gasket	*31047
34	1	Valve Body	239336
35	1	Bare Pump Assembly	245524
36	4	Screw	50169

Item No.	Qty.	Description	Model 84050
37	12	Lock Washer	66186
38	1	Cover	270745
39	1	Elbow	249533
40	8	Bolt	50015
41	8	Lock Washer	66220
42	1	Gasket	*249355
43	1	Pipe Plug	67117
44	1	Gasket	33152
45	1	Container Assembly	242765
46	1	Pipe Plug	67224
47	1	Extension Tube	249356
48	4	Spacer	249833
49	1	Vent Assembly	249536
50	1	Adapter	12213
51	1	Vent Fitting	249354
52	1	Outlet Check Assembly	81938
53	1	Union	66645
54	2	Lockwasher	66246
55	2	Bolt	50016
56	1	Gasket	*31010
57	1	Nut	12538
58	1	Vent Pipe	67420
59	1	Ultrasonic Sensor	270782
60	1	Socket Assembly	237-13442-4
61	2	Bolt	270747
62	1	Follower Assembly	271203
63	4	Carriage Bolt - Long	50084
64	4	Carriage Bolt - Short	249332
65	1	Wiper (Nitrile)	*249331
66	8	Nut	51304
67	1	Follower Weight	249334
68	1	Follower Guide Plate	249333
69	8	Wing Screws (not shown)	252727

\* Suggested service replacement components

+ Sold only as an assembly. Individual parts not available.

## MODEL 85465 TROUBLESHOOTING

Condition	Possible Cause	Corrective Action
Pump does not operate.	No air to pump.	Turn on or connect air supply to pump.
	Airmotor or pump tube malfunction.	Refer to pump service page.
Air seepage from air exhaust while pump is not operating.	Airmotor malfunction.	Refer to pump service page.
Pump Runs excessively.	Pump tube malfunction.	Refer to pump service page.
	Outlet check damage or contamination.	Repair check or remove contamination.
	Vent valve damage or contamination.	Repair vent valve or remove contamination.
	System component leaking.	Repair leaks.
Lubricant leaking from weep hole of pump outlet casting.	Injector bypassing.	Repair injectors.
	Pump tube malfunction.	Refer to pump service page.
Lubricant leaking from safety unloader valve.	Pressure of system set too high.	Adjust pressure switch setting.
	Safety unloader damaged or contaminated.	Replace safety unloader.
Air leaking from weep hole in vent valve.	Vent valve air seal damaged.	Replace air seal.
Lubricant leaking from weep hole in vent valve.	Vent valve lubricant seal damaged.	Replace lubricant seal.

Lincoln Industrial  
 One Lincoln Way  
 St. Louis, MO 63120-1578  
 (+1) 314 679 4200  
[www.lincolnindustrial.com](http://www.lincolnindustrial.com)

Lincoln GmbH  
 69190 Walldorf  
 Heinrich-Hertz Strasse 2-8  
 (+49) 6227 33-0

Lincoln Industrial  
 25 International Business Park  
 #01-68 German Centre  
 Singapore 609916  
 (+65) 562-7960