

**FlowMaster™ Rotary Driven Hydraulic Pump  
Model 85219 With Grease  
Model 85220 Without Grease  
Series "A"**

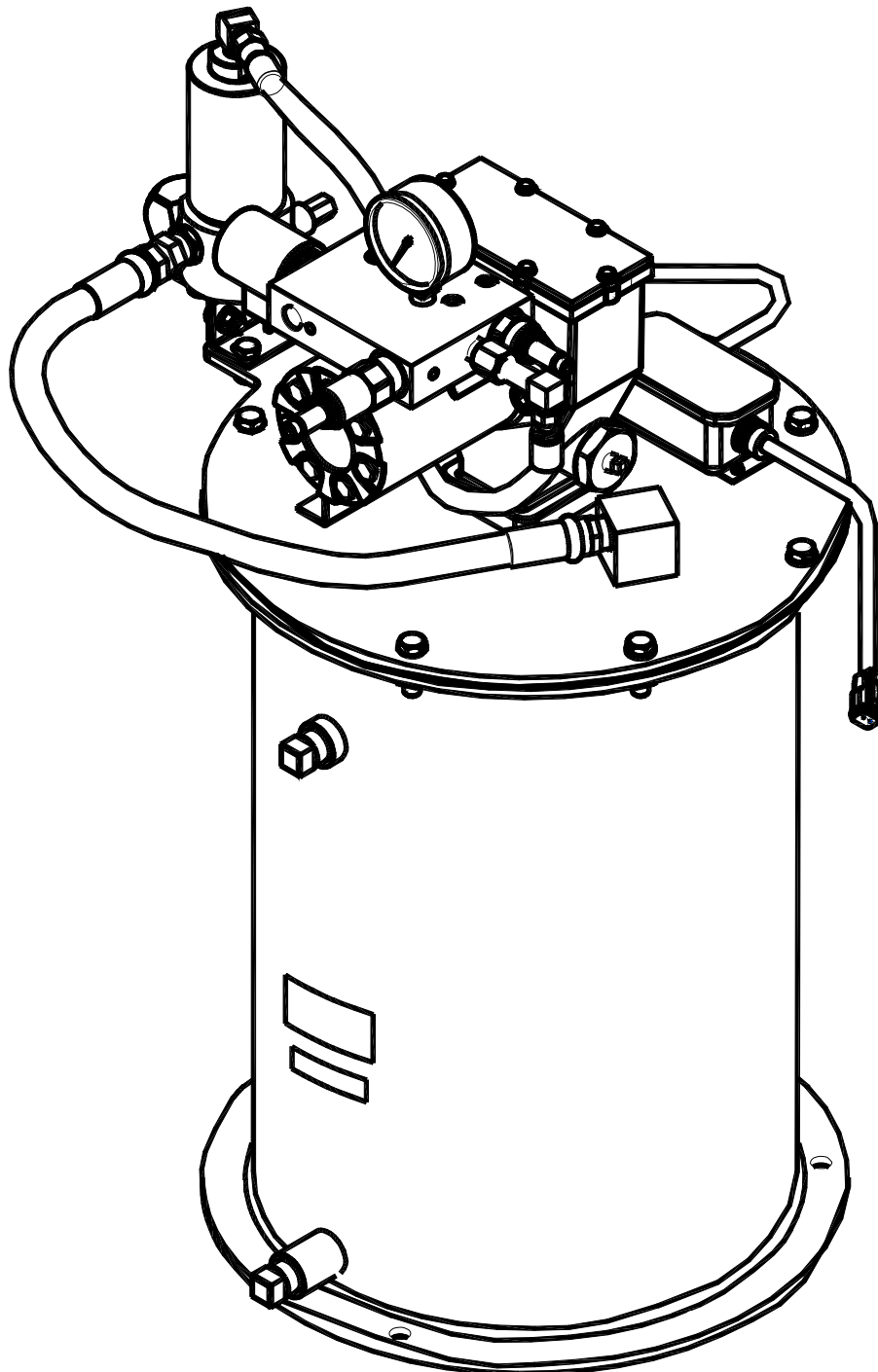



**TABLE OF CONTENTS**

	Page
Safety.....	2
Specifications.....	2
Description.....	2
System Operation.....	2
Installing the Pump.....	3
Putting Pump into Operation.....	3
Maintenance & Repair.....	3
Dimensions.....	6
Repair Parts List.....	7
Troubleshooting.....	8

**SAFETY**

Read and carefully observe these operating instructions before unpacking and operating the pump! The pump must be operated, maintained and repaired exclusively by persons familiar with the operating instructions. Local safety regulations regarding installation, operation and maintenance must be followed.

Operate this pump only after safety instructions and this service manual are fully understood.

**WARNING**

This symbol indicates a potentially hazardous situation which, if not avoided, could result in death or serious injury. Please refer to the 85481 operation manual, section C8, page 269, series “B” for all other safety considerations.

**PRODUCT SPECIFICATIONS**

Supply inlet hydraulic pressure, maximum, PSIG (bar) -	<b>3,000 (207)</b>
Operating working hydraulic pressure, PSIG (bar) -	<b>300 to 450 (21 to 31).</b>
Max. output pressure, PSIG (bar) -	<b>3500 (241)</b>
Hydraulic inlet flow, GPM (l/min) -	<b>Up to 7 (27)</b>
Pump ratio with manifold -	<b>9:1 at low inlet pressure (300 to 350 PSI [21 to 24 bar]) and low inlet flow (below 2 gpm [7.5 lpm]) Pump ratio approaches 11.0:1 ratio at higher inlet pressure and flow.</b>
Ambient oper. temp. °F (°C) -	<b>-20 to +150 (-29 to +66)</b>
Operating voltage, VDC -	<b>24</b>
Hydraulic inlet port, In -	<b>SAE 4</b>
Tank return port, In -	<b>SAE 6</b>
Maximum hydraulic fluid temp., °F (°C) -	<b>200 (93)</b>
Weight, Pump Only Lbs (Kg) -	<b>93 (41)</b>
Container capacity , Lbs (Kg) -	<b>120 (54)</b>

**WARNING**

Do not exceed 3,000 PSIG (207 bar) maximum supply inlet hydraulic pressure or 3500 PSIG (241 bar) maximum outlet pressure. Exceeding the rated pressures may result in damage to system components and personal injury.

**DESCRIPTION**

**General Description**

The Model 85219 is a pumping unit designed to operate a Centro-Matic® lubrication system. The units include a vent valve to relieve the line pressure to recharge the injectors. FlowMaster™ Rotary Driven Hydraulic Pump includes pressure reducing valve, flow control valve and solenoid operated (24 VDC) “On” and “Off” valve.

The FlowMaster pump is fully automatic when used with Model 85530 Controller and a pressure switch. The Flow-Master pump is double acting, dispensing lubricant on both the “Up” and “Down” strokes. This unit is designed to be used with SL-1, SL-11, SL-32 and SL33 series injectors or a combination of these.

**Appropriate Use**

- The pump on this unit is exclusively designed to pump and dispense lubricants using hydraulic power only.
- The maximum specification ratings should not be exceeded.
- Any other use not in accordance with instructions will result in loss of claims for warranty and liability.

**SYSTEM OPERATION**

**Operation with Model 85530 System Controller**

When Model 85530 times out, it will initiate a lube cycle. The solenoid is energized to deliver hydraulic pressure to the pump and vent valve. Pump begins dispensing lubricant through injectors to the bearings.

When all bearings have received lubricant, pressure rises in the system to actuate the pressure switch. When pressure switch actuates, the control is reset to de-energize the solenoid valve cutting off hydraulic oil pressure to the pump and vent valve. Pump stops, pressure vents and pressure switch de-actuates. Control begins timing toward next lube event.

## INSTALLING THE PUMP

Place the unit in the approximate location making sure that electric and hydraulic power connections are accessible. Mark center locations of the four holes at the bottom of the reservoir. Then drill four 5/8" (16 mm) holes. The use of 1/2" (13 mm) bolts will offer some flexibility in securing the reservoir to the equipment.

Lubricant outlet of pump should be connected to system with suitable hose capable of 3,500 PSI (241 bar) working pressure. Hydraulic inlet connection should be made with at least 3/8" (9 mm) I. D. hose capable of at least 3,000 PSI (207 bar) operating pressure. Hydraulic return to tank connection line should be 3/4" (19 mm) I. D. hose or pipe.

Please refer to the 85481 operation manual, section C8, page 269, series "B" for setting the pump pressure and flow control.

## PUTTING PUMP INTO OPERATION

### Filling Reservoir

To bulk fill the reservoir, remove the lower and upper pipe plugs from the side of the reservoir (see Figure 4). Attach the appropriate bulk-filling pump to the lower inlet (3/4 NPT). Fill reservoir until grease appears at the top 1/2 NPT vent high level port. Remove the bulk-filling pump. Replace both pipe plugs.

### WARNING

When filling the reservoir, caution should be used as extreme pressure can cause damage to the reservoir or serious personal injury.

## MAINTENANCE & REPAIR

### General Maintenance

- Keep area around pump clean. Clean off filling port area prior to filling reservoir. Clean area around filler after filling as lubricants will attract dirt.
- Keep lubricants clean and free of dirt and debris.
- When replacing grease pails be especially careful to prevent any foreign matter from entering the grease pail or contaminating the grease, as it adheres to the pump.

### In Case of System Malfunction

#### (See Trouble Shooting Chart Page 8)

- Use the **Trouble Shooting Charts** to determine where to look if problems occur.
- See the sections below for replacement and repair of specific areas of the check valve, vent valve or safety unloader valve.

- Each part is identified with a number keyed to the matching part on the illustrated views.
- General recommendations of tools required are also specified in each step.
- Pay particular attention to the **Warning** statements to prevent personal injury and possible damage to pump components.

### Outlet Check Service

#### (See Figures 1, 2, 9 & 10, Pages 4, 5 & 6)

The pump will not build up sufficient lubricant pressure if the outlet check (42) is fouled. Foreign material may lodge beneath the Check Ball (21) or between check disc (17) and the seat of bushing assembly (18). Sealing surfaces of the seat must form a perfect seal. Clean parts or replace if pitted, worn or scored.

1. Turn off and disconnect the hydraulic and electric power supply to the pump assembly.
2. Standard tools required are a bench mounted vice, a set of open end wrenches ranging from 7/16" to 1-1/2", a large 24" (600 mm) adjustable wrench and a smaller 10" (254 mm) adjustable wrench.
3. Remove bolts and lock washers (47 & 48).
4. Loosen adapter union. Set vent valve assembly to the side.
5. Remove entire outlet check assembly (42) by loosening adapter (41) from pump outlet.
6. Remove adapter (41) from outlet check assembly (42).
7. Remove outlet connector (22) from bushing (18).
8. Remove ball check seat (19) from outlet connector (22).
9. Inspect all check components (17, 18, 19, 21) for presence of foreign material, scoring and or other damage, which may cause internal leakage. Replace components if damage is found.
10. If foreign material is present, clean components and reassemble. Be sure to always replace gaskets (16) & (20) whenever vent valve is disassembled. Reverse the above procedure to reassemble. Torque check assembly to 100 ft.-lbs. (13.5 N-M).

### Vent Valve Service (See Figures 3, 9 & 10 Pages 5 & 6)

1. Turn off and disconnect the hydraulic and electrical power supply to the pump assembly.
2. Standard tools required are a bench mounted vice, a set of open end wrenches ranging from 7/16" to 1-1/2", a large 24" (600 mm) adjustable wrench and a smaller 10" (254 mm) adjustable wrench.
3. Loosen Adapter Union (43) and Vent Hose (14).
4. Remove bolts and lock washers (47 & 48). Remove vent valve.
5. Hold base of vent valve in vice to remove elbows (12 & 15). Turn vent valve in vice so that vice jaws are gripping flats machined on base of vent valve.
6. Remove hydraulic cylinder (23). Remove piston and packing (24) from cylinder. If oil leakage was evident from side of hydraulic cylinder then replace packing.

7. Remove packing assembly (26). If grease leakage was evident from side of hydraulic cylinder, then replace packing assembly.
8. Inspect needle (25) and valve seat (27). If foreign matter is lodged and is keeping the needle from sealing in valve seat, clean and inspect for damage. If seat appears damaged by nicks, grooves or scouring it should be replaced. Remove valve seat (27) from valve body (29) by placing a 3/4" open end wrench onto the flats and loosening the seat. The use of an adjustable wrench in place of the open end wrench may be necessary due to the accessibility of the seat.
9. Replace the valve seat (27) if damaged. Also be sure to remove and replace the gasket (28) below the seat.
10. Reassembly is the reverse of the above procedure. Needle (25) and hydraulic cylinder (23) inside diameter should be coated with oil or grease to assist in assembly.
11. Upon reassembly tighten valve seat (27) into body (28) using 25 ft.-lbs. (39 N-M). Tighten hydraulic cylinder (23) onto valve body (29) using 100 ft.-lbs. (135 N-M)

**Follower (see Figures 4, 5 & 6 Page 5)**

If follower wiper appears to be damaged or does not wipe the sides of the container effectively service may be necessary.

1. Disconnect hydraulic supply from pump.
2. Remove the eight bolts (34) and lock washers (35) which attach the cover to the reservoir.
3. Lift the entire pump, vent valve, cover assembly and follower out of the reservoir.
4. Unscrew the low level indicator (3) from the follower plate (45).
5. Now remove the entire follower assembly from the pump tube. After removing the follower assembly from the pump tube wipe off the excess grease which will allow clean access to the eight bolts that must be removed.
6. Loosen and remove the eight nuts (57) on top of the follower.
7. Remove the follower weight and the wiper (55). Replace the wiper with a new one.

8. Reassemble in the reverse of the above procedure making sure that the long bolts are staggered with the small ones and that they extend below the follower.

**Low Level Indicator (see Figure 4 & 5 Page 5)**

If the indicator pin appears to drop prematurely or water is noticeable on top of the follower then the indicator seal (1) may be damaged.

1. Remove the eight bolts (34) and lockwashers (35) which hold the cover on to the reservoir.
2. Inspect the reservoir gasket seal (36) for damage. If damage is apparent then replace the gasket seal.
3. Remove the entire pump, vent valve and follower assembly from the reservoir.
4. Remove the retaining ring (51) from the indicator rod assembly (3).
5. Hold the indicator plug (4) with a wrench while removing the indicator nut (2).
6. Remove and replace the O-ring (1).
7. Reassemble in the reverse of the above procedure. Torque the indicator nut (2) to 20 ft.-lbs.

**Safety Unloader Valve (See Figure 1 Below)**

Safety unloader valve (11) is not serviceable and should be replaced if malfunction is apparent. Upon reassembly, tighten to 10 ft.-lbs. (13.5 N-M).

The Safety Unloader (11) is set to open at 3,750 to 4,250 PSI lubricant pressure. If pressure Switch fails to operate and shut off hydraulic supply to pump, the Safety Unloader will open at approximately 4,000 PSI to relieve lubricant supply line pressure (Safety Unloader is preset and cannot be adjusted.)

**Bare Pump Assembly (See Figure 4 Page 5)**

Please refer to the Operation Manual (C8, Page 269 series) for the bare pump assembly (30).

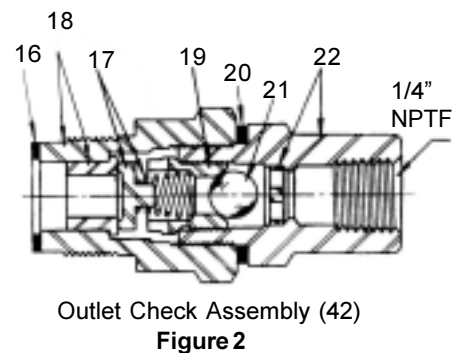
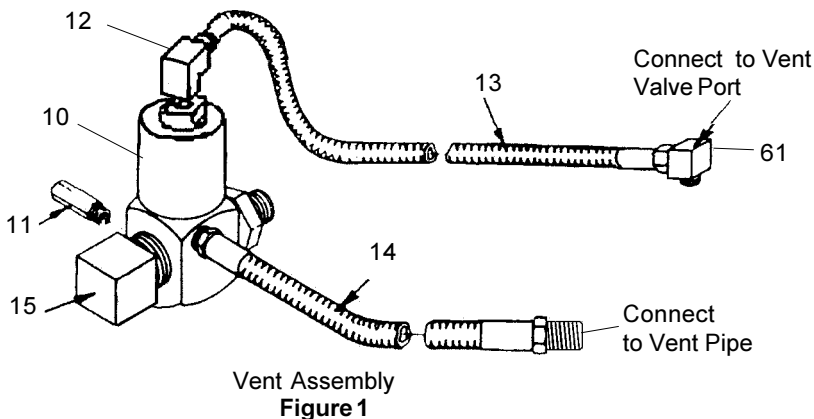

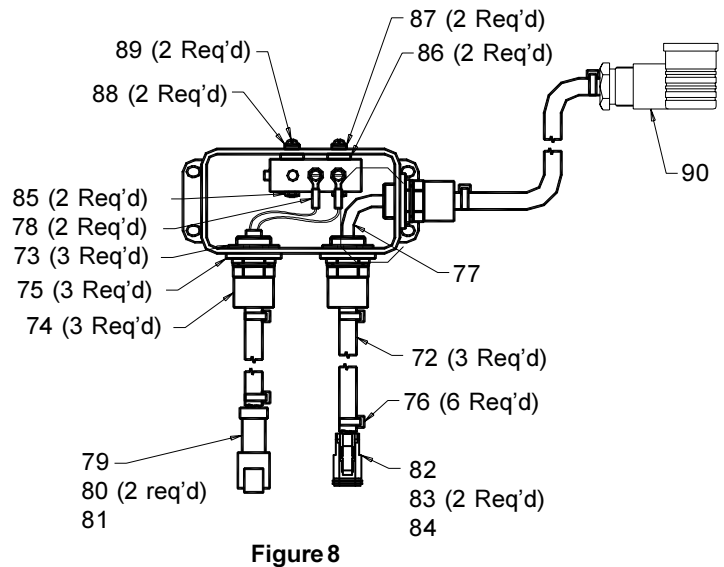
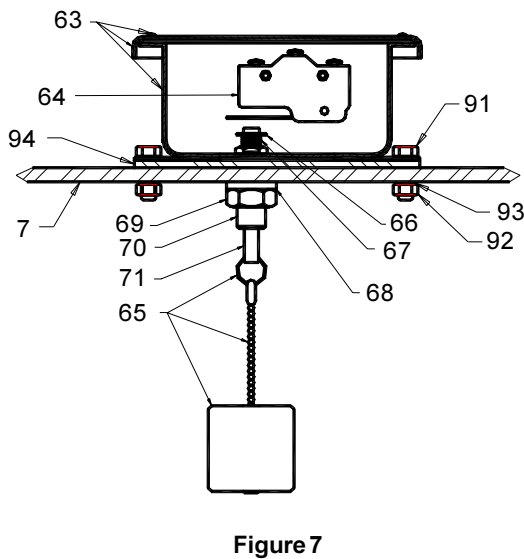
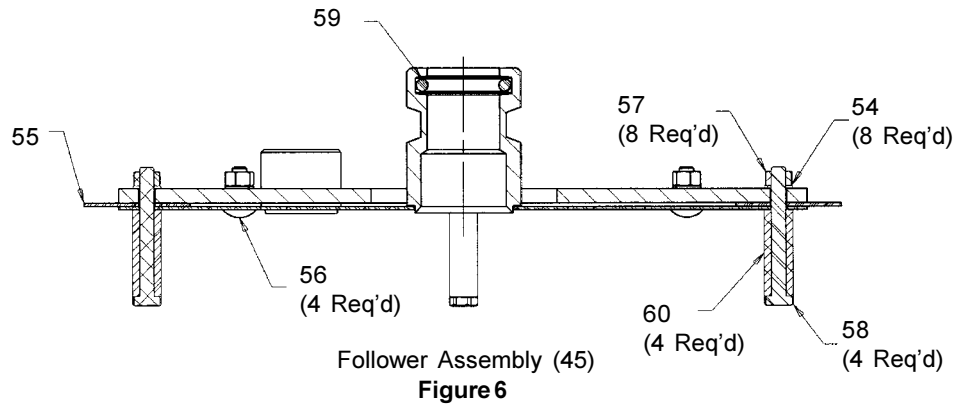
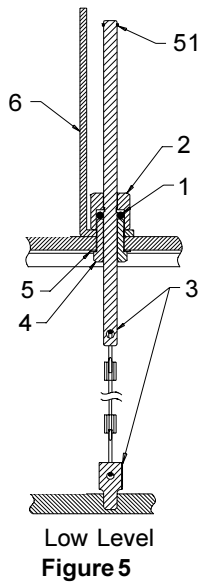
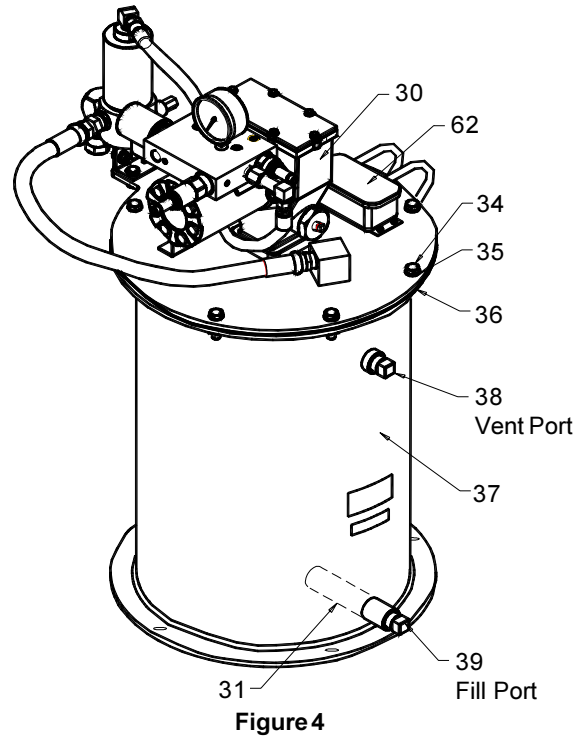
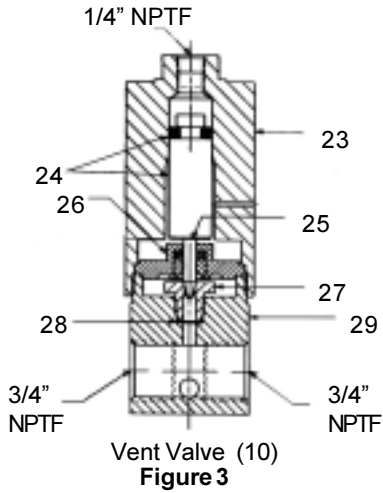

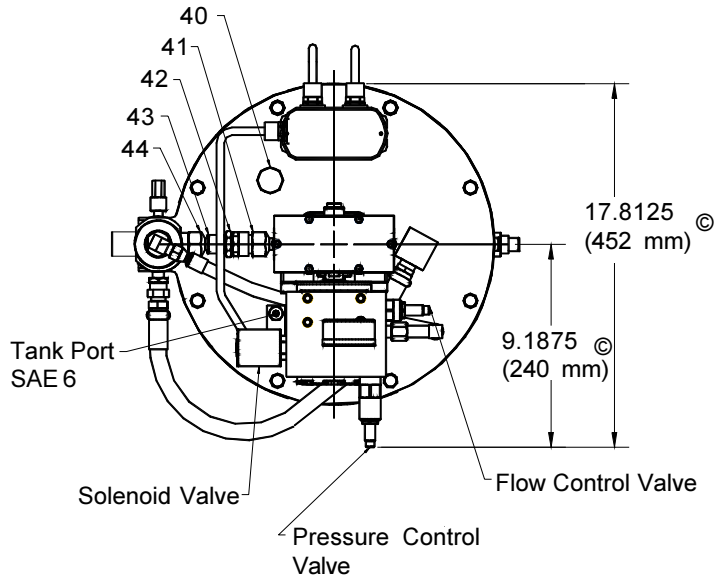

Figure 9

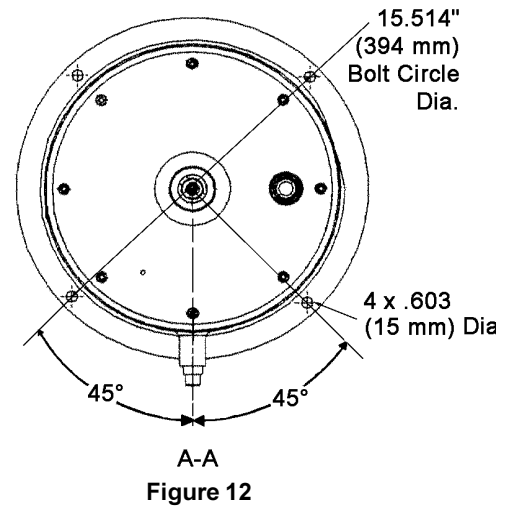

Figure 12

© Indicates change

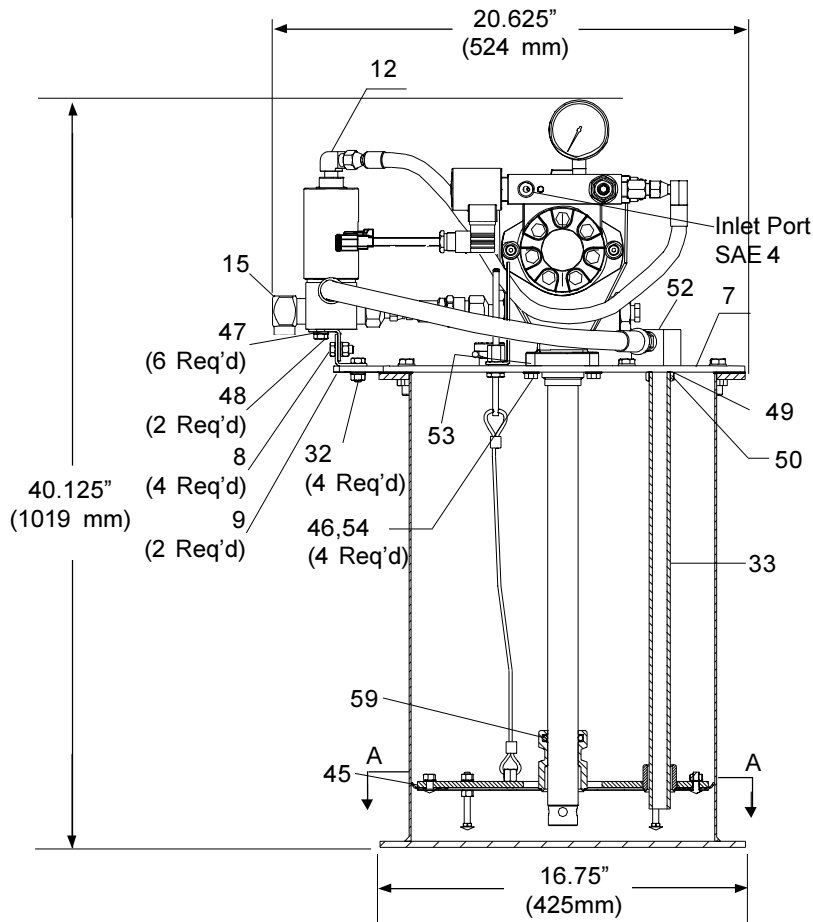

Figure 10



**SERVICE PARTS**

Item No.	Qty.	Description	Model 85219	Item No.	Qty.	Description	Model 85219
1	1	O-Ring	*249532	48	2	Bolt	50034
2	2	Indicator Nut	16352	49	1	Gasket	*31010
3	1	Cable Assembly	271609	50	1	Nut	12538
4	1	Indicator Plug	249357	51	1	Retaining Ring	*68888
5	1	Washer	48548	52	1	Elbow	249533
6	1	Indicator Bracket	361020	53	1	Gasket	33152
7	1	Drum Cover	271646	54	12	Lock Washer	66186
8	4	Bolts	50016	55	1	Wiper	*271909
9	2	Bracket	270723	56	4	Bolt (Short)	50033
10	1	Vent Valve Assembly	84980	57	8	Nut	51304
11	1	Safety Unloader Ass'y	*90942	58	4	Bolt (Long)	50062
12	1	Elbow	20012	59	1	O-Ring	270720
13	1	Hydraulic Hose	271598	60	4	Spacer	249833
14	1	Vent Hose	270726	61	1	Adapter Elbow	271599
15	1	Male Pipe Adapter	271913	62	1	Conduit Box Assembly	271908
16	1	Gasket	*31029	63	1	Conduit Box	271650
17	1	Pump Check Disc Ass'y	+*80206	64	1	Micro Switch	68758
18	1	Outlet Check Bushing	+*90204	65	1	Weight Assembly	271652
19	1	Ball Check Seat	*10313	66	1	E-Ring	66765
20	1	Gasket	*31001	67	1	Spring	55302
21	1	Steel Ball (3/8" Dia.)	*66001	68	1	Lock Washer	69181
22	1	Outlet Connector	90860	69	1	Nut	51039
23	1	Hydraulic Cylinder	241807	70	1	5/8 Hex Stud	271654
24	1	Piston	+*244673	71	1	Rod	14259
25	1	Needle	*14722	72	3	Sheathing	271915
26	1	Viton Packing Ass'y	+*239330	73	3	Conduit Locknut	68020
27	1	Valve Seat	*14723	74	3	Straight Male Cord Conn.	271656
28	1	Check Seat Gasket	*31047	75	2	Sealing O-Ring	271911
29	1	Valve Body	239336	76	6	Wire Tie	236911
30	1	Bare Pump Assembly	85480	77	2	Wire	271914
31	1	Extension Tube	271943	78	2	Insulated Terminal Ring	324059
32	4	Hex Nut	51026	79	1	2-Way Deutsch Plug	271651
33	1	Vent Pipe	67290	80	2	Contact Pin	271655
34	8	Bolt	50015	81	1	Wedge Lock	271658
35	8	Lock Washer	66220	82	1	2-Way Deutsch Plug	252834
36	1	Gasket	*271944	83	2	Contact Pin	252833
37	1	Container Assembly	271649	84	1	Wedge Lock	252835
38	1	Pipe Plug, Vent	67117	85	2	Nut	51080
39	1	Pipe Plug, Fill	67224	86	2	Packing	34413-15
40	1	Vent Fitting	249354	87	2	Gasket	34748
41	1	Adapter	12213	88	2	Washer	48350
42	1	Outlet Check Assembly	81938	89	2	Screw	50618
43	1	Adapter Union	66645	90	1	Plug	242708
44	1	Reducer Nipple	14727	91	4	Screw	50088
45	1	Follower Assembly	271653	92	4	Nut	51100
46	4	Screw	50169	93	4	Lock Washer	68991
47	6	Lock Washer	66246	94	1	Gasket	271657

\* Suggested service replacement components

\* Suggested service replacement component

+ Sold as an assembly. Individual parts not available.



**MODELS 85219 TROUBLESHOOTING**

<b>CONDITION</b>	<b>POSSIBLE CAUSE</b>	<b>CORRECTIVE ACTION</b>
Pump does not operate.	No hydraulic power to pump.	Turn on or connect hydraulic supply to pump.
	No pressure on gauge: - Closed Supply line shut off valve. - No power to solenoid valve. - Faulty Solenoid. - Pressure Reducing Valve is set too low. - Insufficient Hydraulic Fluid supply.	Open shut-off valve. Correct electrical fault. Replace solenoid. Reset Pressure Reducing Valve. Check hydraulic supply for proper pressure and flow.
	Pressure is shown on gauge on pump manifold. - Closed Fluid outlet line.	Check outlet line and clear obstructions. Readjust flow control valve to 1 turn open.
	- Pump is stalled due to grease backpressure.	Check vent valve in system.
	Pump is seized or damaged.	Dismantle the pump and repair defective or seized component. See pump service page.
Pump runs excessively.	Pump tube malfunction.	Refer to pump service page.
	Outlet check damage or contamination.	Repair check or remove contamination.
	Vent valve damage or contamination.	Repair vent valve or remove contamination.
	System component leaking.	Repair leaks.
	Vent valve not receiving proper pressure to keep it closed.	Orifice fitting plugged.
	Injector bypassing.	Repair injectors.
Pump speeds up or runs erratically.	Low level of grease or reservoir is empty	Refill reservoir.
	Follower plate is stuck and separated from grease.	Check follower plate and container for damage.
	Pump piston or checks are worn.	Refer to pump service sheet.
Pump runs, but output is low.	Insufficient hydraulic fluid supply.	Check hydraulic supply and adjust flow.
	Inlet pressure too low.	Increase pressure at pressure control valve.
	Faulty inlet or discharge check valve in pump.	Replace faulty components. See pump service page.
Lubricant leaking from safety unloader valve.	Pressure of system set too high.	Adjust pressure switch setting.
	Safety unloader damaged or contaminated.	Replace safety unloader.
Lubricant leaking from weep hole in vent valve.	Vent valve lubricant seal damaged.	Replace lubricant seal.

**Americas:**  
One Lincoln Way  
St. Louis, MO 63120-1578  
USA  
Phone +1.314.679.4200  
Fax +1.800.424.5359

**Europe/Africa:**  
Heinrich-Hertz-Str 2-8  
D-69183 Walldorf  
Germany  
Phone +49.6227.33.0  
Fax +49.6227.33.259

**Asia/Pacific:**  
25 Int'l Business Park  
#01-65 German Centre  
Singapore 609916  
Phone +65.562.7960  
Fax +65.562.9967

© Copyright 2002  
Printed in USA  
Web site:  
[www.lincolnindustrial.com](http://www.lincolnindustrial.com)