

### SPECIFICATIONS

SINGLE STROKE, SPRING RETURN

Ratio	Lubricant Output (Cu. In.)	Reservoir Capacity	Air Inlet	Lubricant Outlet	Lubricant Operating Pressure (P.S.I.)			
					Type of System	Minimum	Maximum	Recommended
17.5:1	.8*	4-1/2 pints	1/4" N.P.T. Female	1/4" N.P.T. Female	SL-42	750	1,000	850
					SL-43	with 45 P.S.I. Air	with 60 P.S.I. Air	with 50 P.S.I. Air
					SL-32	1,200	3,500	1,500
SL-33	with 70 P.S.I. Air	with 200 P.S.I. Air	with 90 P.S.I. Air					
SL-1	1,850	3,500	2,500					
	with 110 P.S.I. Air	with 200 P.S.I. Air	with 145 P.S.I. Air					

\*Based on lubricants that are free of entrapped air. Lubricants that are aerated will reduce output of pump.

The 82571 Pump is used as the pumping unit for a centralized lubrication system having a single line circuit of SL-1, SL-32, SL-33, SL-42, and/or SL-43 Injectors dispensing oil.

It is an air operated, single stroke spring return pump that discharges \*.8 cu. in. of lubricant into the circuit for each pump stroke (Lubrication Cycle).

The total quantity of lubricant needed for the lubrication cycle of the system must not exceed the amount of lubricant discharged per pump stroke.

### TO FILL RESERVOIR

The reservoir can be filled through the filler cap at the top of the reservoir.

A strainer is located at the filler cap to prevent the induction of foreign material into the lubricant reservoir. Inspect strainer before filling reservoir. When necessary, lift strainer out and clean thoroughly.

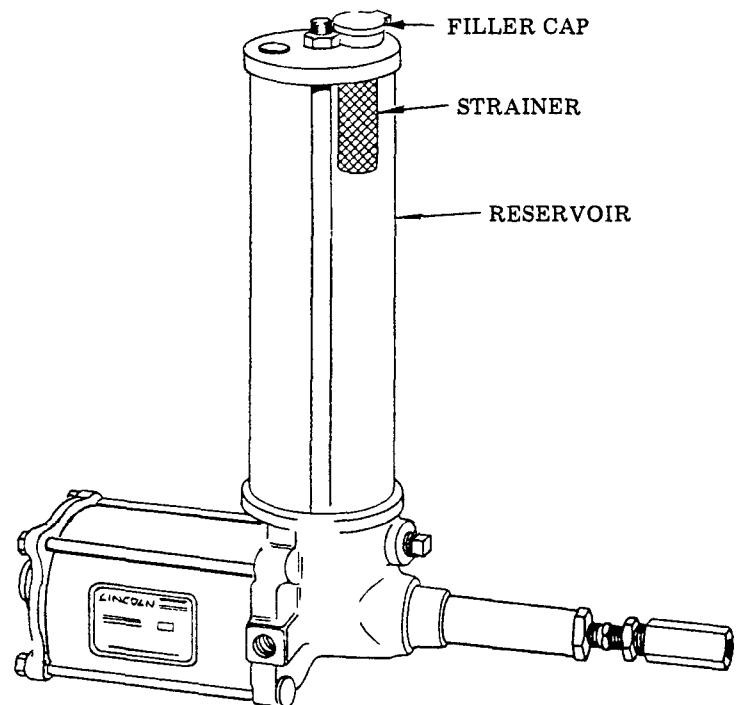

### TO PRIME SYSTEM

**SUPPLY LINES:** After pump reservoir has been filled with recommended lubricant, loosen (do not remove) all plugs in dead ends of the injector manifolds and supply lines. Operate pump until lubricant flows from around threads of any loosened plug. Tighten this plug and continue to operate pump until lubricant flows from around threads of another loosened plug. Repeat this procedure until all supply lines are primed.

**FEEDER LINES:** Fill each feed line with lubricant before connecting lines to outlet of injectors and bearings. This will prevent having to cycle each injector to fill line between injector and bearing.

**INJECTORS:** Check each injector for proper operation. Injector stem moves when injector discharges lubricant to bearing. This may require cycling system several times. After checking injectors for operation adjust injector for the volume required for each bearing.

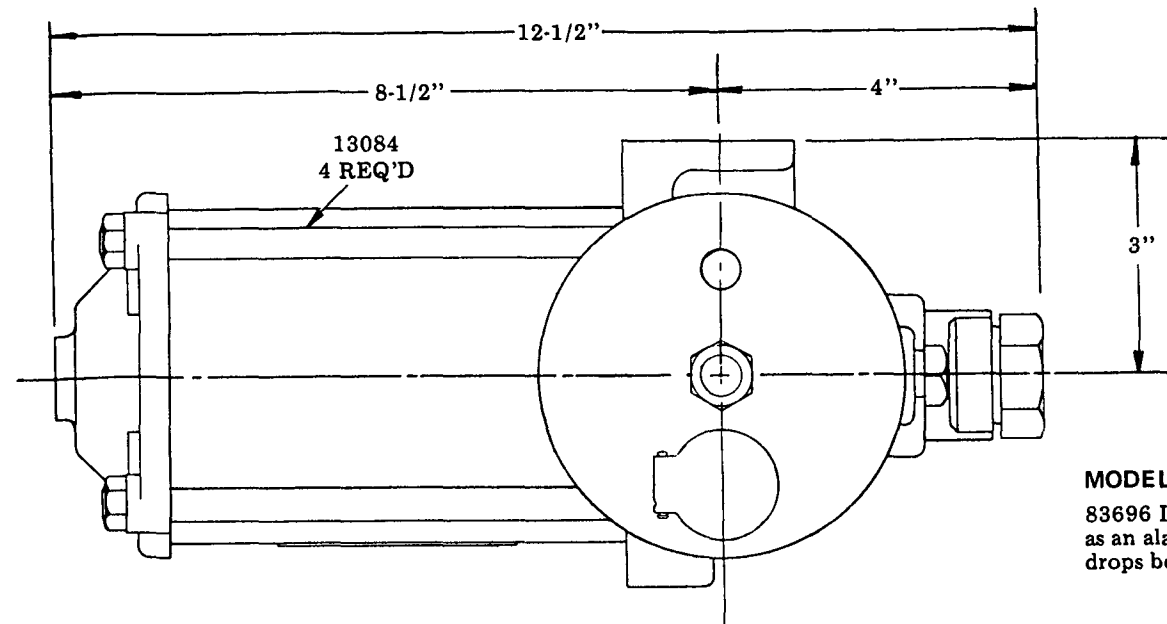

**MODEL 83696**  
83696 Low Level Cut-Off Kit may be used as an alarm or signal device when lubricant drops below an acceptable level.

**MODEL 82571  
SINGLE STROKE PUMP**

NOTE: TORQUE TO 10 FT. LBS.

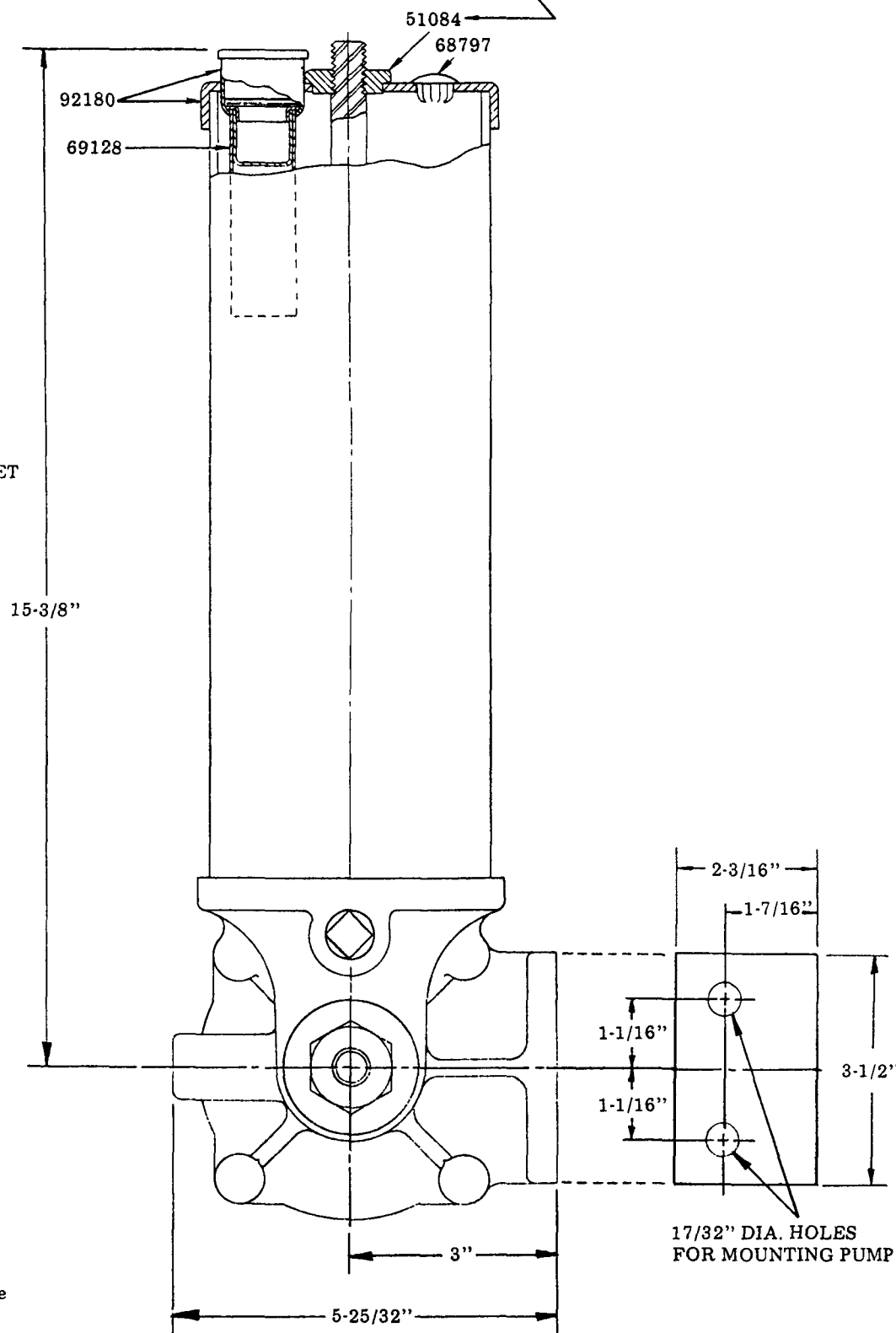

**TO CLEAN LINE CHECK 83114**  
Remove 91733 Check. Examine packing for presence of foreign particles. If packing is damaged, replace 91733 Check.  
  
Remove 66250 Ball Check, 55194 Spring and 13649 Ball Stop from 13557 Check Retainer. Examine for presence of foreign particles. Clean thoroughly.

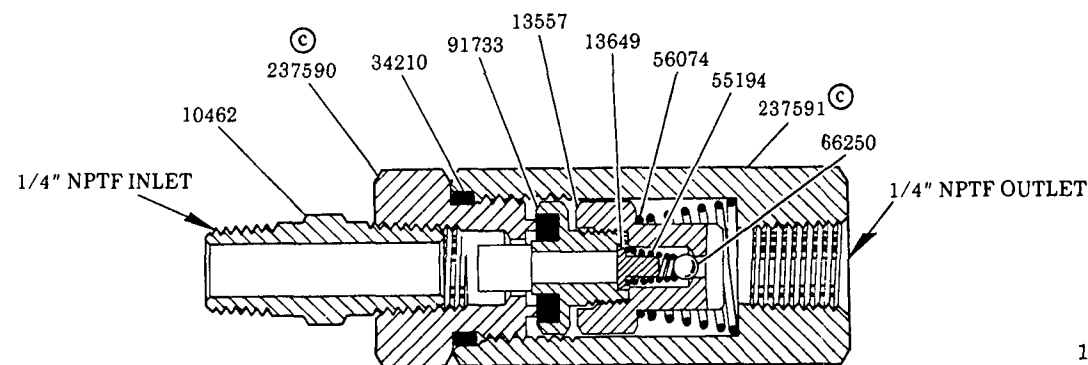

**83114  
LINE CHECK**

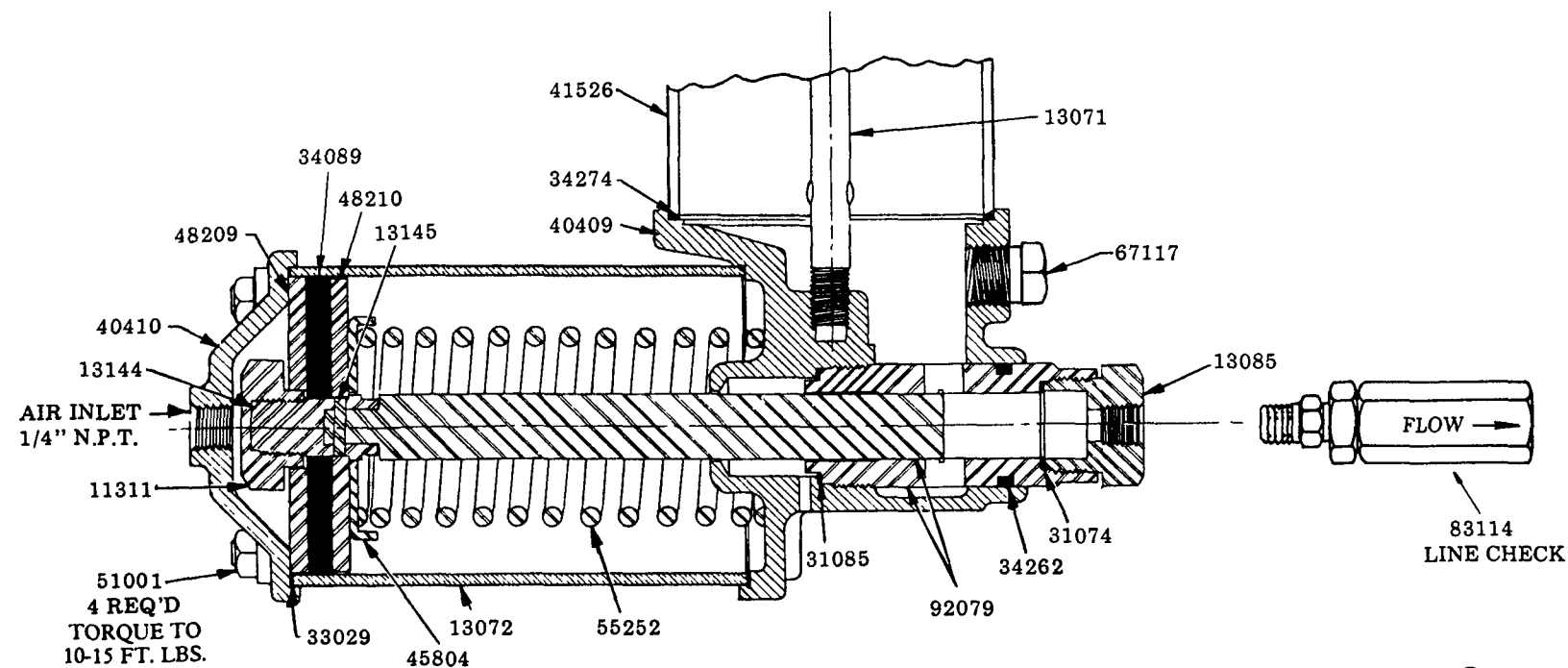

© Indicates change

## TYPES OF INSTALLATIONS

Frequency of lubrication cycle can be controlled Manually, Mechanically or Electrically — Pump requires a three-way air valve for operation.

### MECHANICAL CONTROL

When using mechanical motion of machine to control lubrication frequency, three-way valve is engaged by cam permitting air to pass through valve to pump forcing air piston forward and lubricant through supply line to injectors. When the valve is disengaged, air exhausts back through valve and spring in pump returns air piston completing lubrication cycle. Cam dwell on three-way valve must be arranged for a minimum of 10 seconds.

When mechanical motion of machine is too rapid to be used as a source of control for frequency of lubrication cycle, a cycle timer with adjustable settings may be used. (See separate instructions for No. 83764 Cycle Timer). Cam dwell arrangement for 10 seconds is not required for this type installation.

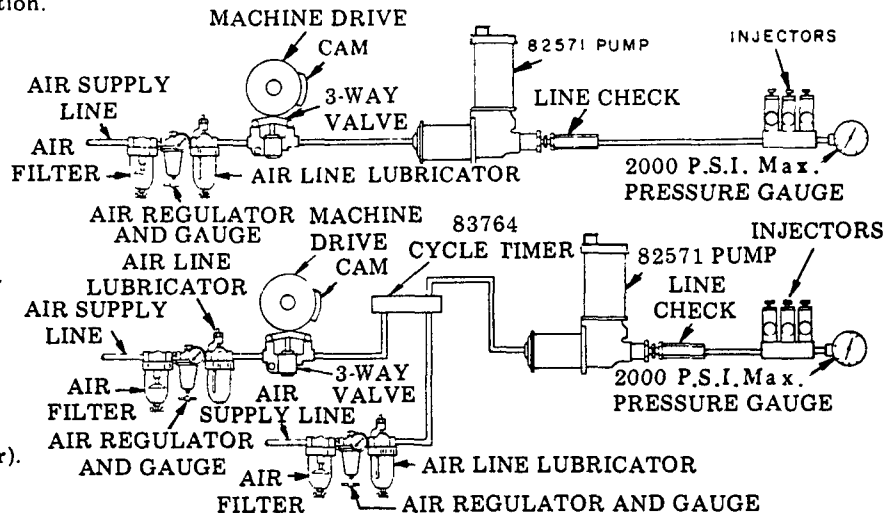

### ELECTRICAL CONTROL

Electrical time switch opens three-way solenoid valve permitting air to flow to pump forcing air piston forward and lubricant through supply line to injectors. When valve closes, air exhausts back through valve and spring in pump returns air piston completing lubrication cycle. Frequency of cycle can be set as desired by adjustable pins in time switch. (See separate instructions for 84101 Program Timer, Section C8, Page 136 Series.)

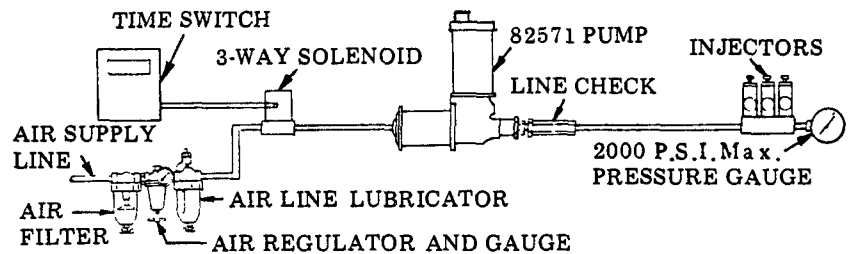

### MANUAL CONTROL

Opening three-way valve for a minimum of 10 seconds permits air to flow to pump forcing air piston forward and lubricant through supply line to injectors. When valve is closed, air exhausts back through valve and spring in pump returns air piston completing lubrication cycle.

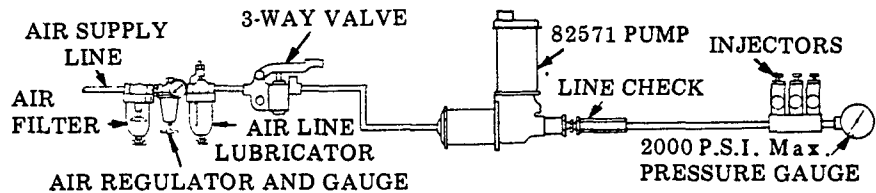

### WHAT TO DO IF:

**PUMP LOSES PRIME** — Check lubricant supply.

**SYSTEM FAILS TO CYCLE** and calculated system planning has been followed — lubricant is leaking by packing of 91733 Check or 66250 Check. Remove and clean. Failure of injectors to cycle can also be caused by leak in supply lines. Examine supply lines and connections.

**PUMP FAILS TO OPERATE** — Check air supply.

## SERVICE PARTS

Part	Description	Part	Description	Part	Description
10462	Nipple	* 34089	Packing	55252	Spring
11311	Piston nut	* 34210	O-ring	56074	Spring
13071	Tie rod	* 34262	O-ring	* 66250	Steel ball
13072	Air cylinder	* 34274	Gasket	67117	Pipe plug
13084	Tie rod	40409	Body casting	68797	Plug button
13085	Outlet	40410	Cylinder	69128	Strainer
13144	Packing stud	41526	Reservoir	83114	Line check assembly
13145	Pin	45804	Spring guide	* 91733	Check
13557	Check retainer	48209	Washer	92079	Bushing & plunger
13649	Ball stop	48210	Washer	92180	Cover cap assembly
* 31074	Gasket	51001	Nut	237590	Check seat
* 31085	Gasket	51084	Nut	237591	Check body
* 33029	Gasket	* 55194	Spring		

\* Recommended service parts inventory.

### RETAIN THIS INFORMATION FOR FUTURE REFERENCE

When ordering replacement parts, list: Part Number, Description, Model Number, and Series Letter.

LINCOLN provides a Distributor Network that stocks equipment and replacement parts.