

SPECIFICATIONS

SINGLE STROKE, AIR RETURN

Ratio	Lubricant Output (cu. in.)	Reservoir Capacity	Air Inlet	Lubricant Outlet	Lubricant Operating Pressure (P.S.I.)			
					Type of System	Minimum	Maximum	Recommended
31:1	*1.4	4 lb	1/4" N.P.T. Female	1/4" N.P.T. Female	SL-1	1,850 With 60 P.S.I. Air	3,500 With 113 P.S.I. Air	2,500 With 82 P.S.I. Air
					SL-32 SL-33	1,200 With 40 P.S.I. Air	3,500 With 113 P.S.I. Air	1,500 With 50 P.S.I. Air

* Based on lubricants that are free of entrapped air. Lubricants that are aerated will reduce output of pump.

The 82653 Pump is used as the pumping unit for a centralized lubrication system having a single line circuit of SL-1, SL-32 or SL-33 Injectors. Dispenses grease up through N.L.G.I. No. 1.

It is an air operated single stroke pump requiring air for both forward and return stroke and discharges *1.4 cu. in. of lubricant into the circuit for each pump stroke (Lubrication Cycle).

The total quantity of lubricant needed for the lubrication cycle of the system must not exceed the amount of lubricant discharged per pump stroke.

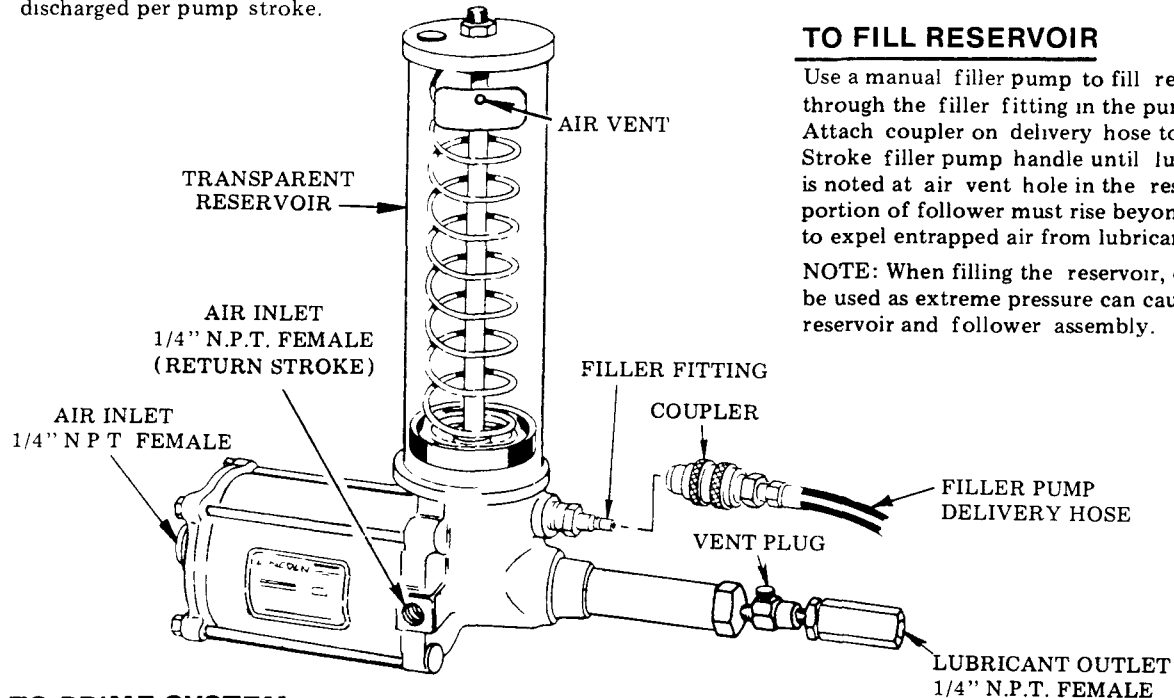

TO FILL RESERVOIR

Use a manual filler pump to fill reservoir through the filler fitting in the pump body. Attach coupler on delivery hose to filler fitting. Stroke filler pump handle until lubricant weepage is noted at air vent hole in the reservoir (lower portion of follower must rise beyond air vent hole to expel entrapped air from lubricant).

NOTE: When filling the reservoir, caution should be used as extreme pressure can cause damage to reservoir and follower assembly.

TO PRIME SYSTEM

SUPPLY LINES: After pump reservoir has been filled with recommended lubricant, turn vent plug counter-clockwise one complete turn and operate pump until lubricant flows freely from opening in vent plug to expel air pockets trapped between the pump and the supply line connection. Tighten vent plug. Remove all plugs in dead ends of the injector manifolds and supply lines. Operate pump until lubricant flows from any plug opening. Close opening with plug. Continue operating pump until lubricant flows from another plug opening. Repeat this procedure until all supply lines are primed and plug openings closed.

FEEDER LINES: Fill each feed line with lubricant before connecting lines to outlet of injectors and bearings. This will prevent having to cycle each injector for every inch of feed line between injector and bearing.

INJECTORS: Check each injector for proper operation. Injector stem moves when injector discharges lubricant to bearing. This may require cycling system several times. After checking injectors for operation adjust injectors for the volume required for each bearing.

Model 82653

AIR OPERATED SINGLE STROKE GREASE PUMP

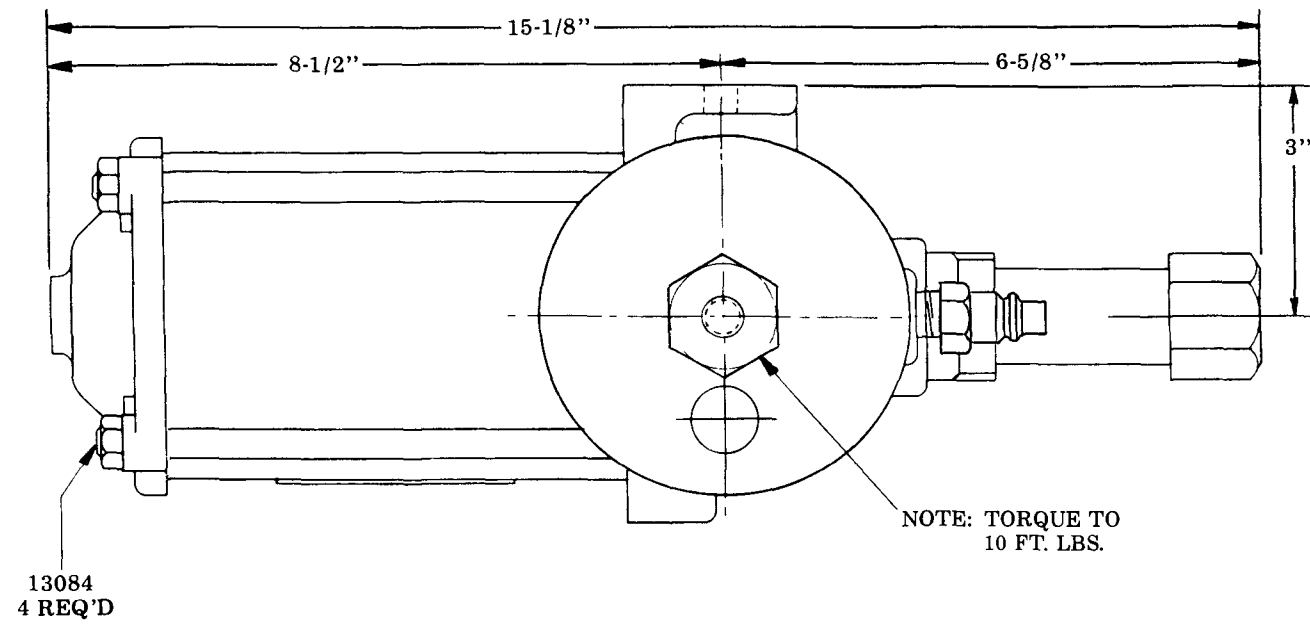

MODEL 83671

83671 Low Level Cut-Off Kit may be used as an alarm or signal device when lubricant drops below an acceptable level.

TO CLEAN LINE CHECK 83114

Remove 91733 Check and examine packing for presence of foreign particles. If packing is damaged, replace 91733 Check.

Remove 66250 Ball Check, 55194 Spring and 13649 Ball Stop from 13557 Check Retainer. Examine for presence of foreign particles. Clean thoroughly.

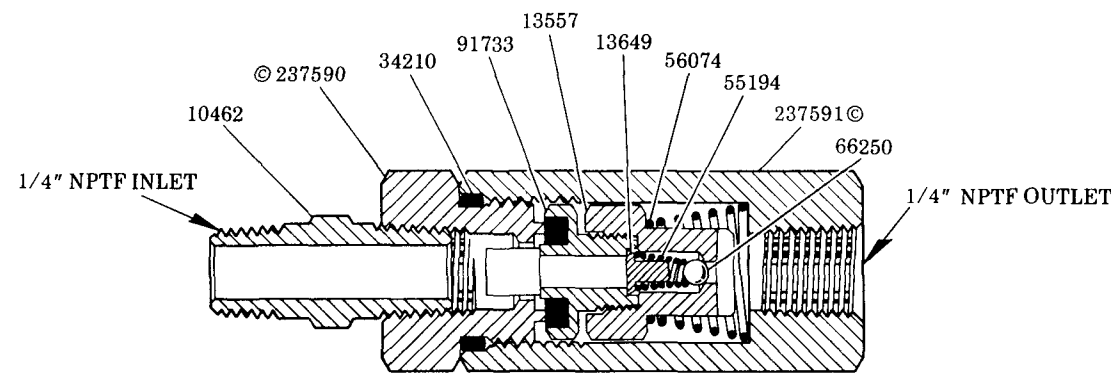

83114
LINE CHECK

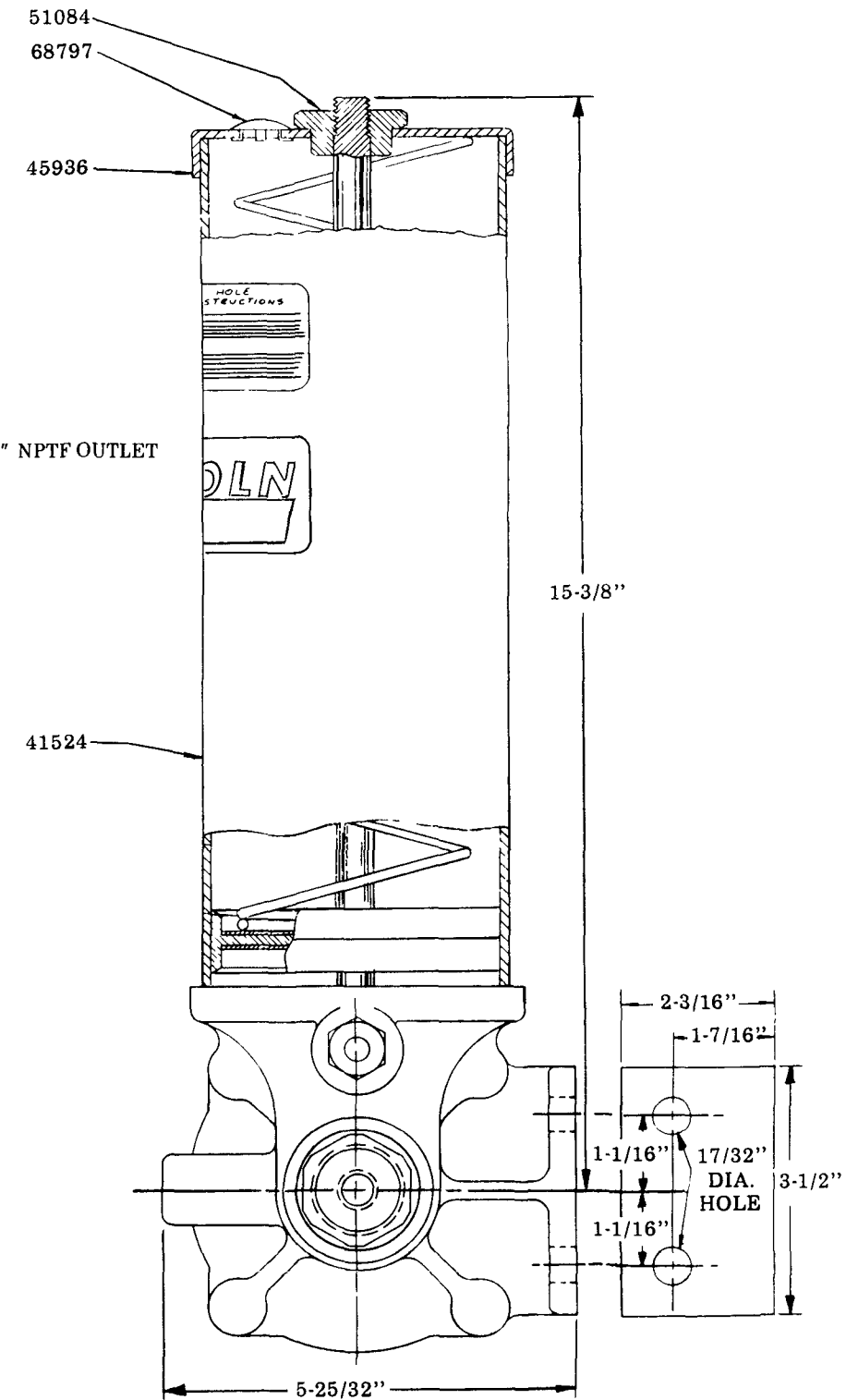

SCREW FOLLOWER OVER
THREADS ON 13071 ROD.
DO NOT FORCE

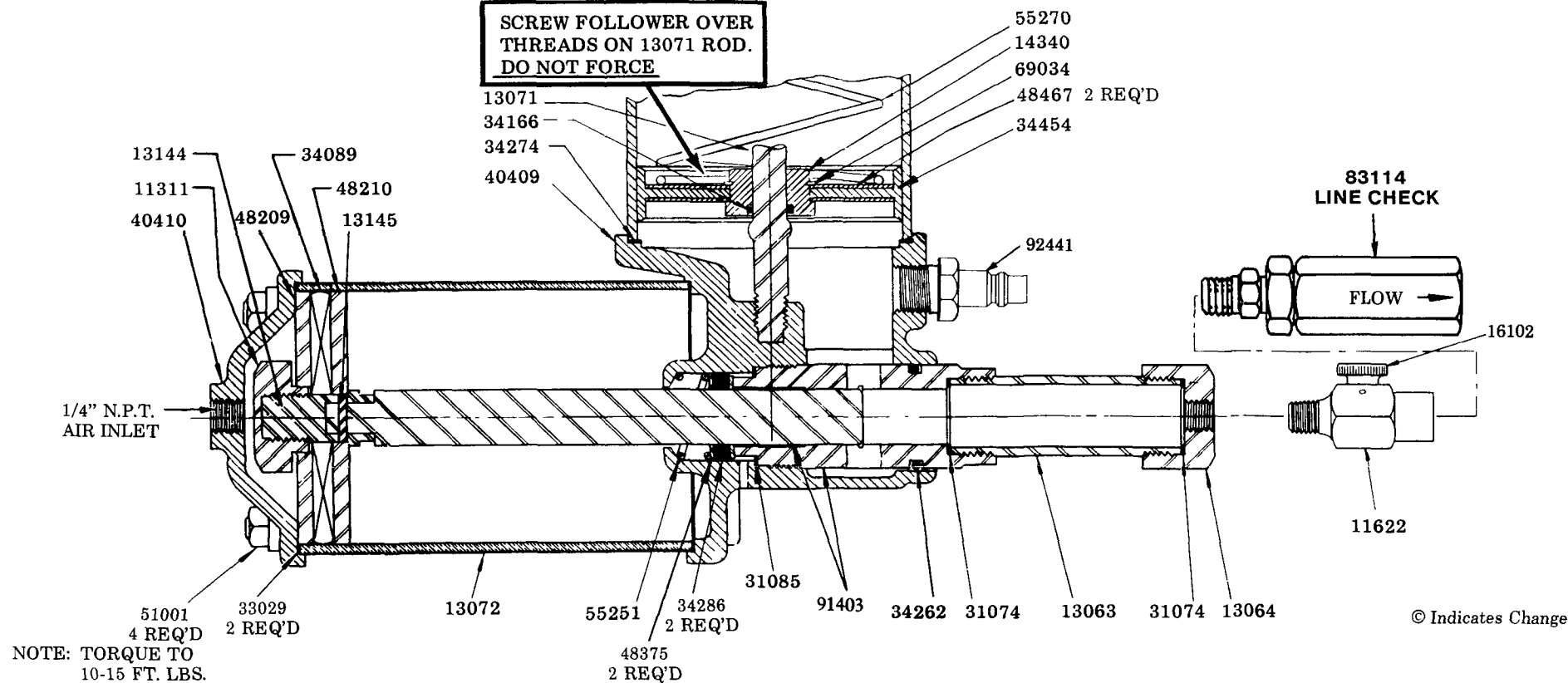

TYPES OF INSTALLATIONS

Frequency of Lubrication Cycle can be controlled Manually, Mechanically or Electrically —
Pump requires a four-way air valve for operation.

MECHANICAL CONTROL

When using mechanical motion of machine to control lubrication frequency, four-way valve is engaged by cam permitting air to pass through valve to pump forcing air piston forward and lubricant through supply line to injectors. When valve is disengaged, air exhausts back through valve. Air also flows into return side of pump reversing air piston and completing lubrication cycle. Cam Dwell on four-way valves must be arranged for a minimum of 10 seconds.

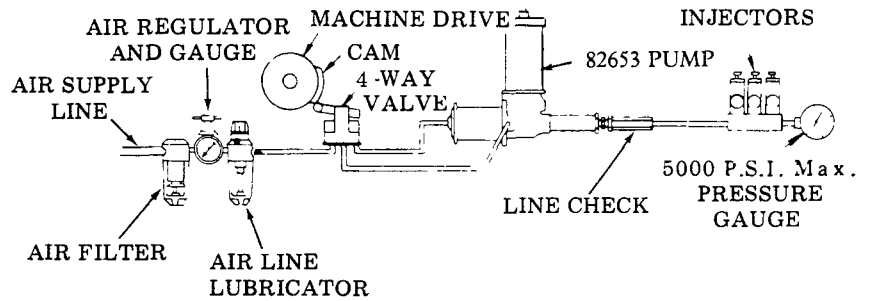

ELECTRICAL CONTROL

Electrical time switch opens four-way valve permitting air to flow to pump forcing air piston forward and lubricant through supply line to injectors. When valve closes, air exhausts back through valve. Air also flows into return side of pump reversing air piston and completing lubrication cycle. Frequency of cycle can be set as desired by adjustable pins in time switch. (See separate instructions for 84101, Time Switch, Section C8, Page 136 Series)

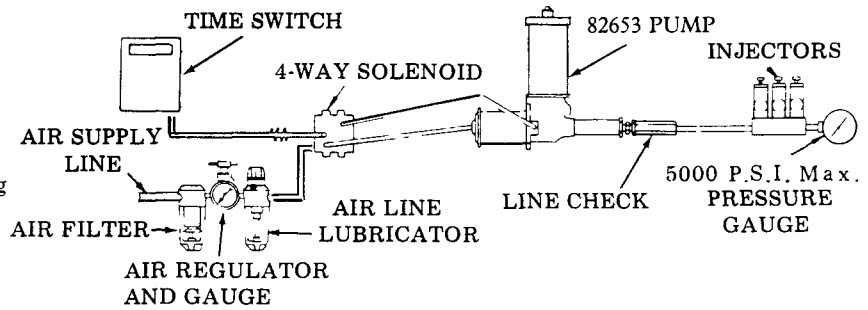

MANUAL CONTROL

Opening four-way valve for a minimum of 10 seconds permits air to flow to pump forcing air piston forward and lubricant through supply line to injectors. When valve is closed, air exhausts back through valve. Air also flows into return side of pump reversing air piston and completing lubrication cycle.

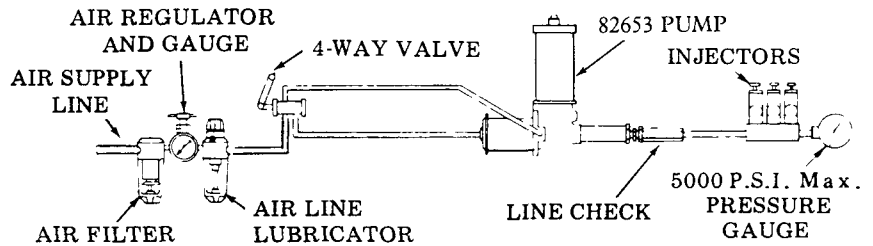

WHAT TO DO IF:

PUMP LOSES PRIME - Check lubricant supply.

SYSTEM FAILS TO CYCLE and calculated system planning has been followed - Lubricant is leaking by packing of 91733 Check or the 66250 Check. Remove and clean. Failure of injectors to cycle can also be caused by a leak in supply lines. Examine supply lines and connections.

PUMP FAILS TO OPERATE - Check air supply.

SERVICE PARTS

Part	Description	Part	Description	Part	Description
10462	Nipple	* 31074	Gasket	48375	Washer
11311	Piston nut	* 31085	Gasket	48467	Washer
11622	Body	* 33029	Gasket	51001	Nut
13063	Pump tube	* 34089	Packing	51084	Nut
13064	Outlet	* 34166	O-ring	* 55194	Spring
13071	Tie rod	* 34210	O-ring	55251	Spring
13072	Air cylinder	* 34262	O-ring	55270	Spring
13084	Tie rod	* 34274	Gasket	* 56074	Spring
13144	Packing stud	* 34286	Gland packing	* 66250	Steel ball
13145	Pin	* 34454	Follower packing	68797	Plug button
13557	Check retainer	40409	Body casting	69034	Retaining ring
13649	Ball stop	40410	Cylinder cap	83114	Line check assembly
14340	Bushing	41524	Reservoir	91403	Bushing & plunger
16102	Vent plug	45936	Cover cap	* 91733	Check
237590	Check seat	48209	Washer	92441	Filler fitting
237591	Check body	48210	Washer		

* Recommended service parts inventory

RETAIN THIS INFORMATION FOR FUTURE REFERENCE

When ordering replacement parts, list: Part Number, Description, Model Number, and Series Letter.

LINCOLN provides a Distributor Network that stocks equipment and replacement parts.