

**SINGLE STROKE, AIR RETURN (WITH ELECTRIC CONTROLS)**

RATIO	LUBRICANT OUTPUT (cu. in.)	RESERVOIR CAPACITY	AIR INLET	LUBRICANT OUTLET	LUBRICANT OPERATING PRESSURE			
					TYPE OF SYSTEM	MINIMUM	MAXIMUM	RECOM-MENDED
31:1	1.4*	4 LB. (120 cu. in.)	1/4" NPTF(F)	1/4" NPTF(F)	SL-1	1,850 With 60 PSI Air	3,500 With 113 PSI Air	2,500 With 82 PSI Air
					SL-32 SL-33	1,200 With 40 PSI Air	3,500 With 113 PSI Air	1,500 With 50 PSI Air

\*Based on lubricants that are free of entrapped air. Lubricants that are aerated will reduce output of pump.

The pumping unit is for a centralized lubrication system having a single line circuit of SL-1 and/or SL-32, SL-33 or Injectors. It dispenses grease up through N.L.G.I. No. 1.

It is an air operated single stroke pump requiring air for both forward and return stroke that discharges \*1.4 cu. in. of lubricant into the circuit for each pump stroke (Lubrication Cycle).

The total quantity of lubricant needed for the lubrication cycle of the system must not exceed the amount of lubricant discharged per pump stroke.

**Electrical Power Requirements**

AC 120/60, 110/50  
Inrush: 20 Volt-Amps (.167 Amps)  
Holding Current: 15 Volt-Amps (.125 Amps)

FOR 84501 PROGRAM TIMER REFER TO SERVICE MANUAL SECTION C8, PAGE 222 SERIES

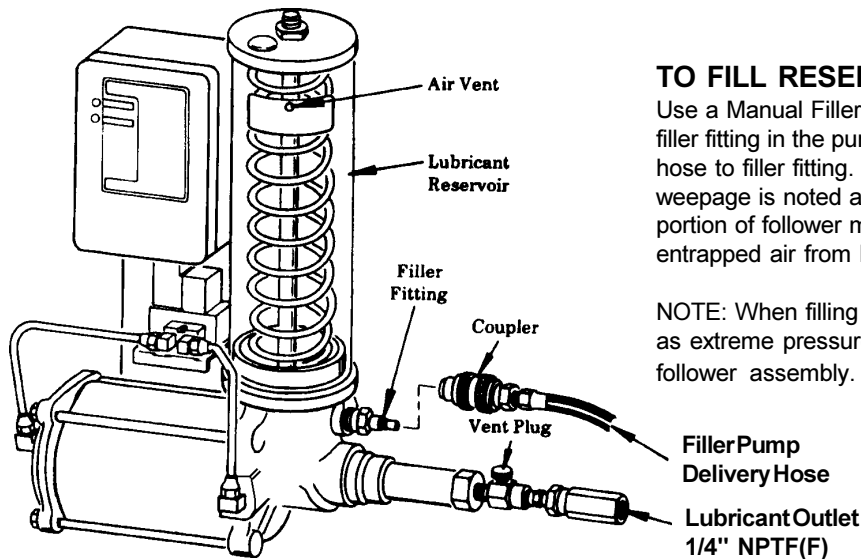

**TO FILL RESERVOIR**

Use a Manual Filler Pump 81834 to fill reservoir through the filler fitting in the pump body. Attach coupler on delivery hose to filler fitting. Stroke filler pump handle until lubricant weepage is noted at air vent hole in the reservoir (lower portion of follower must rise beyond air vent hole to expel entrapped air from lubricant).

NOTE: When filling the reservoir, caution should be used, as extreme pressure can cause damage to reservoir and follower assembly.

**TO PRIME SYSTEM**

**Supply Lines:** After pump reservoir has been filled with recommended lubricant, turn vent plug counterclockwise one complete turn and operate pump until lubricant flows freely from opening in vent plug to expel air pockets trapped between the pump and the supply line connection. Tighten vent plug. Remove all plugs in dead ends of the injector manifolds and supply lines. Operate pump until lubricant flows from any plug opening. Close opening with plug. Continue operating pump until lubricant flows from another plug opening. Repeat this procedure until all supply lines are primed and plug openings closed.

**Feeder Lines:** Fill each feed line with lubricant before connecting lines to outlet of injectors and bearings. This will prevent having to cycle each injector to fill line between injector and bearing.

**Injectors:** check each individual injector for proper operation. Injector stem moves when injector discharges lubricant to bearing. This may require cycling system several times. After checking injectors for operation, adjust injectors for the volume required for each bearing.

**TO CLEAN 83114 CHECK ASSEMBLY:**

Remove 91733 Check. Examine packing for presence of foreign particles. If packing is damaged, replace 91733 Check.

Remove 66250 Ball Check, 55194 Spring and 13649 Ball Stop from 13557 Check Retainer. Examine for presence of foreign particles. Clean thoroughly.

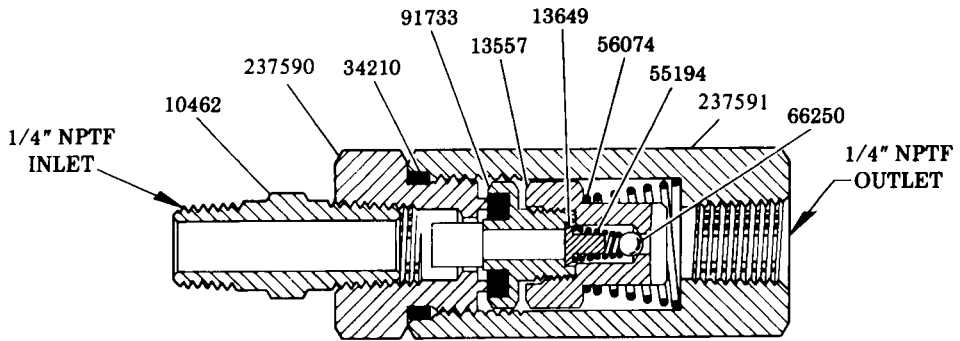

**83114 CHECK ASSEMBLY**

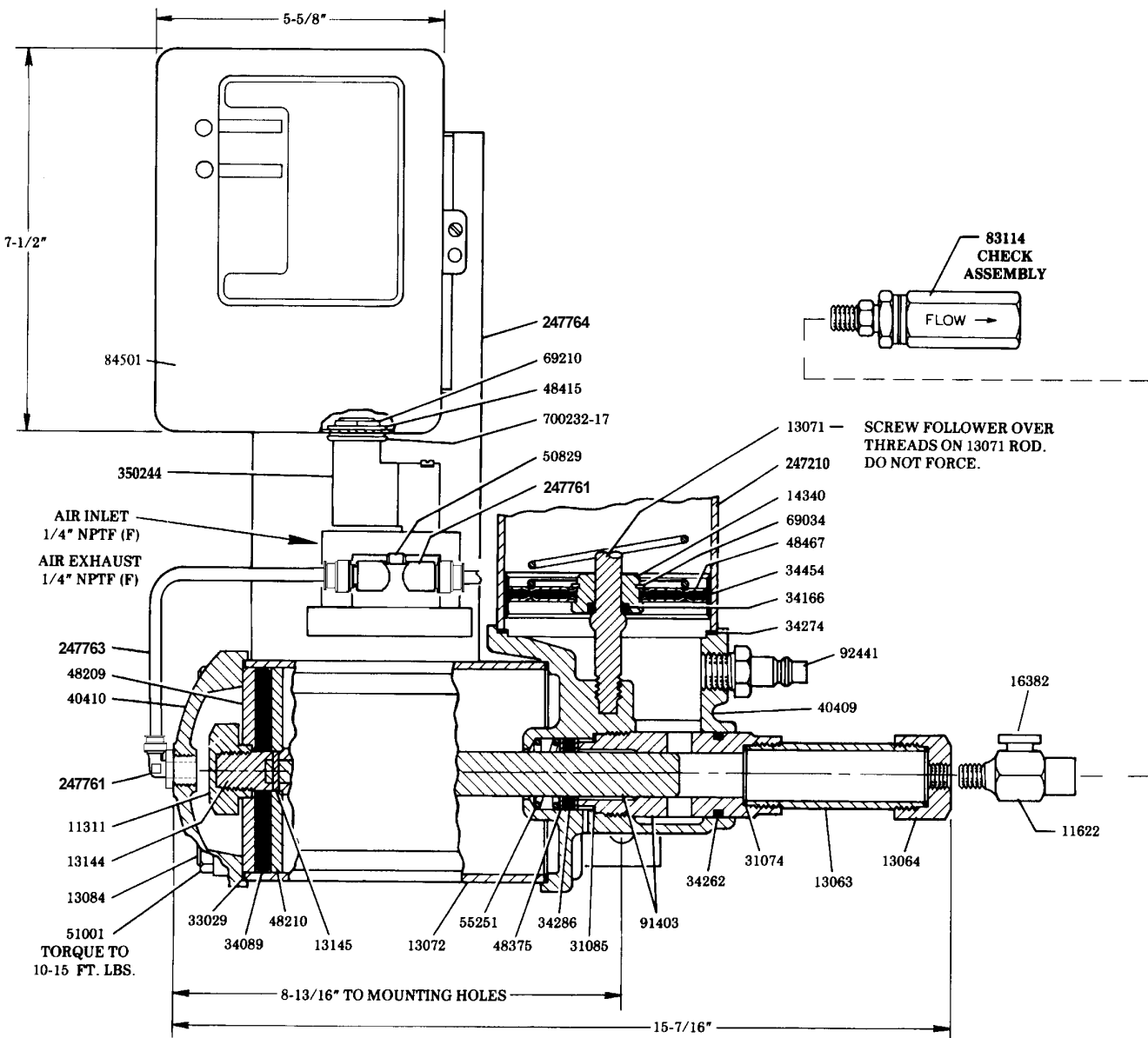

**MODEL 82655**  
**AIR OPERATED SINGLE STROKE OIL PUMP**  
**(WITH ELECTRIC CONTROLS)**

**Model 83671 (Optional)**  
 83671 Low Level Cut-Off Kit may be used  
 as an alarm signal device when lubricant drops  
 below an acceptable level.

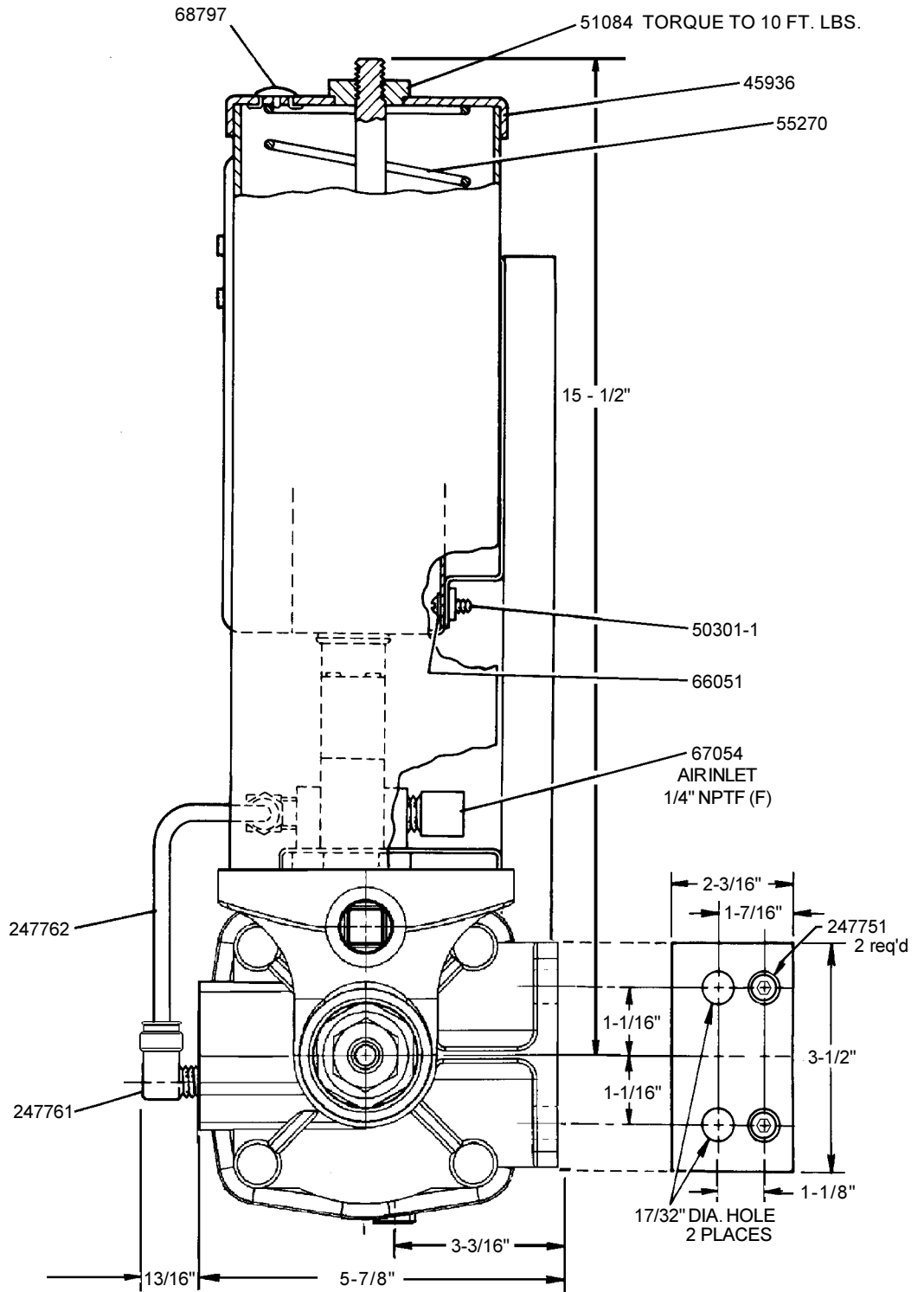

## OPERATION

The pre-determined lubrication cycle frequency is set on the adjustable program timer (Refer to Service Manual, Section C8, Page 222 Series for proper setting).

When a lubrication cycle is initiated either manually or by the timer, the air solenoid valve is energized and air is admitted to the pump. Lubricant is delivered to the injectors and the injectors discharge lubricant to bearings. When manual lube switch is released or timer times out, air is admitted to the opposite side of the pump air cylinder. As pump plunger returns to its retracted position, the lubricant pressure in the system is relieved, permitting the injectors to recharge.

System is now ready for the next lubrication cycle.

## WHAT TO DO IF:

### PUMP LOSES PRIME:

Check lubricant supply.

### SYSTEM FAILS TO CYCLE AND CALCULATED SYSTEM PLANNING HAS BEEN FOLLOWED:

Lubricant is leaking by packing of 91733 Check or the 66250 Check. Remove and clean. Failure of injectors to cycle can also be caused by a leak in supply lines. Examine supply lines and connections.

### PUMP FAILS TO OPERATE:

Check air supply.

## SERVICE PARTS

Part	Qty.	Description	Part	Qty.	Description
10462	1	Nipple	48415	1	Washer
11311	1	Piston nut	48467	2	Washer
11622	1	Body	50301-1	2	Screw
13063	1	Pump tube	50829	2	Screw
13064	1	Outlet	51001	4	Nut
13071	1	Tie Rod	51084	1	Nut
13072	1	Air cylinder	*55194	1	Spring
13084	4	Tie Rod	55251	1	Spring
13144	1	Packing Stud	55270	1	Spring
13145	1	Pin	56074	1	Spring
13557	1	Check retainer	66051	4	Lockwasher
*13649	1	Ball Stop	*66250	1	Ball
14340	1	Bushing	67054	1	Elbow
16382	1	Vent plug	68797	1	Plug button
*31074	2	Gasket	69034	1	Retaining ring
*31085	1	Gasket	69210	1	Chase nipple
*33029	2	Gasket	83114	1	Check assembly
*34089	1	Packing (Nitrile)	84501	1	Program timer
*34166	1	O-ring (Nitrile)	91403	1	Bushing & plunger
*34210	1	O-ring (Nitrile)	*91733	1	Check
*34262	1	O-ring (Nitrile)	92441	1	Filler fitting
*34274	1	Gasket (Neoprene)	237590	1	Check seat
*34286	2	Gland (Nitrile)	237591	1	Check body
*34454	1	Follower Packing (Nitrile)	247210	1	Reservoir assembly (Acrylic)
40409	1	Body casting	247751	2	Screw
40410	1	Cylinder cap	247761	4	Tube fitting
45936	1	Cover cap	247762	1	Tubing (Polyurethane)
48209	1	Washer	247763	1	Tubing (Polyurethane)
48210	1	Washer	247764	1	Support
48375	2	Washer	350244	1	Solenoid
			700232-17	1	Gasket

© \*Included in 252715 Soft Parts Kit

© Indicates Change

### RETAIN THIS INFORMATION FOR FUTURE REFERENCE

When ordering replacement parts, list: Part Number, Description, Model Number and Series Letter.  
LINCORN provides a Distributor Network that stocks equipment and replacement parts.