

**SPECIFICATIONS**

Ratio	Output Per Stroke (Cu. In.)	Reservoir Capacity	Air Inlet	Lubricant Outlet	Lubricant Operating Pressure (P.S.I.G.)			
					Type of System	Minimum	Maximum	Recommended
20:1	*.450	1-1/4 Pints	1/4" N.P.T. Female	1/4" N.P.T. Female	SL-32	1,200	3,500	1,500
					SL-33	with 60 P.S.I.G. Air	with 175 P.S.I.G. Air	with 75 P.S.I.G. Air
					SL-42 SL-43	750 With 38 P.S.I.G. Air	1,000 With 50 P.S.I.G. Air	850 With 43 P.S.I.G. Air

\*Based on Lubricants that are free from entrapped air. Lubricants that are aerated will reduce output of pump.

The 82885 Pump is used as the Pumping Unit for a Centralized Lubrication System having a Single Line Circuit of SL-32, SL-33, SL-42 or SL-43 Injectors. It is an Air Operated, Single Stroke, Spring return pump that discharges .450 cu. in. into the circuit for each pump cycle.

The total quantity of lubricant needed for the Lubrication Cycle of the system must not exceed the amount of lubricant discharged per Pump Stroke.

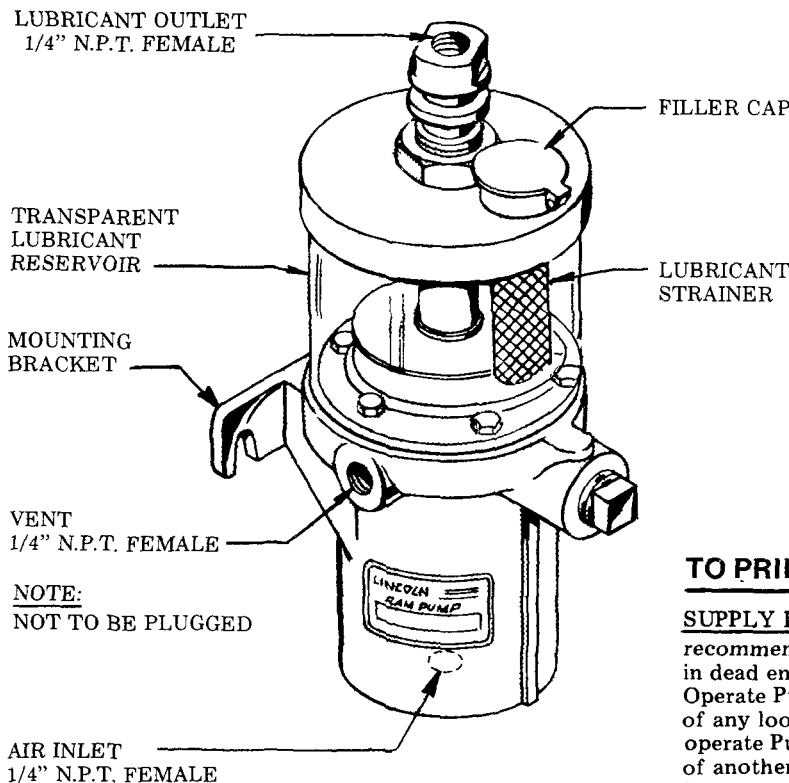

**TO FILL RESERVOIR**

The Transparent Lubricant Reservoir is filled through the Filler Cap at the top of the Reservoir.

The Lubricant Strainer should be removed from the Filler Cap and cleaned periodically.

**TO PRIME SYSTEM**

**SUPPLY LINES:** After Pump Reservoir has been filled with recommended lubricant, loosen (do not remove) all plugs in dead ends of the Injector Manifolds and Supply Lines. Operate Pump until Lubricant flows from around threads of any loosened plug. Tighten this plug and continue to operate Pump until Lubricant flows from around threads of another loosened plug. Repeat this procedure until all Supply Lines are primed and all plugs are securely tightened.

**FEEDER LINES:** Fill each Feed Line with Lubricant before connecting lines to outlet of Injectors and Bearings. This will prevent having to cycle each Injector to fill Line between Injector and Bearing.

**INJECTORS:** Check each Injector for proper operation. Injector Stem moves when Injector discharges Lubricant to Bearing. This may require cycling System several times. After checking Injectors for operation adjust Injectors for the volume required for each Bearing.

**NOTE:**  
 NOT TO BE PLUGGED

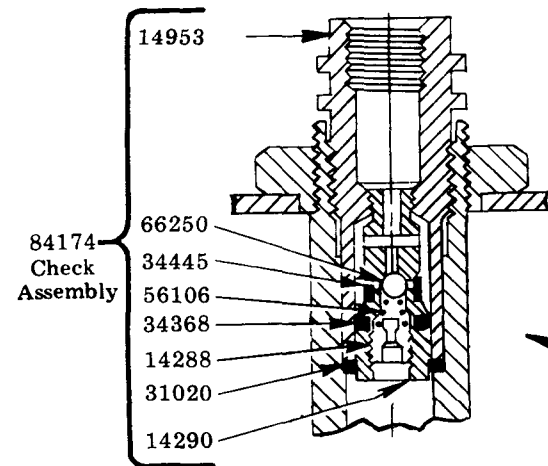

**IMPORTANT:**

Pump must be installed in a vertical position.

**OPERATION OF THE PUMP**

Lubricant in the 41513 Transparent Reservoir flows into the cavity in the 92685 Bushing and Plunger Assembly.

Compressed air entering the bottom of the 41238 Air Cylinder (1/4" N.P.T. female) moves the 40477 Piston upward. As the Piston moves upward, the Plunger is also moved upward into the Bushing. As the Plunger moves upward, it moves the charge of lubricant from the Bushing Cavity through the 84174 Outlet Check to the outlet of the Pump.

When the air pressure to the 41238 Air Cylinder is relieved, the 55289 Piston Spring moves the Piston and Plunger downward. In its extreme down position, the Plunger has retracted below the Bushing Port, permitting lubricant to flow into the bushing cavity.

**WHAT TO DO IF:**

Pump loses prime. — Check lubricant supply.

System fails to cycle and calculated system planning has been followed. — Lubricant may be leaking by the 66250 Ball Check or the 34445 Packing in the 84174 Check and Vent Assembly. Remove these parts and examine for presence of foreign particles. Clean, or replace parts if worn or damaged.

Pump fails to operate. - Check air supply. Failure of Injectors to cycle can be caused by a leak in the supply line.

**NOTE:**

In reassembling the 84174 Check and Extension Assembly, the vent pressure must be reset. Vent pressure can be varied by the Adjusting Screw, 14288. The recommended pressure setting is 25 P.S.I.G. minimum to 75 P.S.I.G. maximum. An improper setting will affect the pump efficiency. Assemble 14288 with non-hardening Loctite or stake threads after adjusting vent pressure.

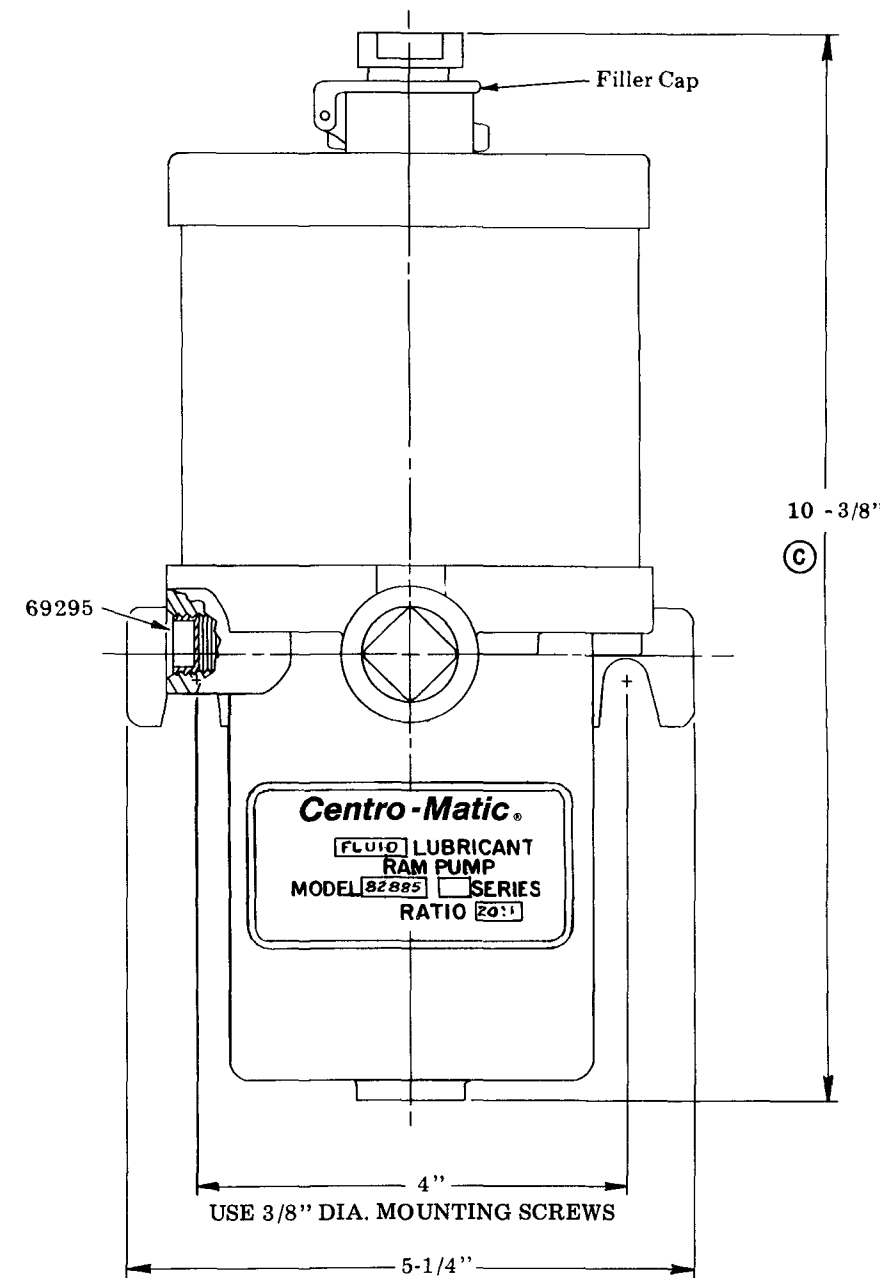
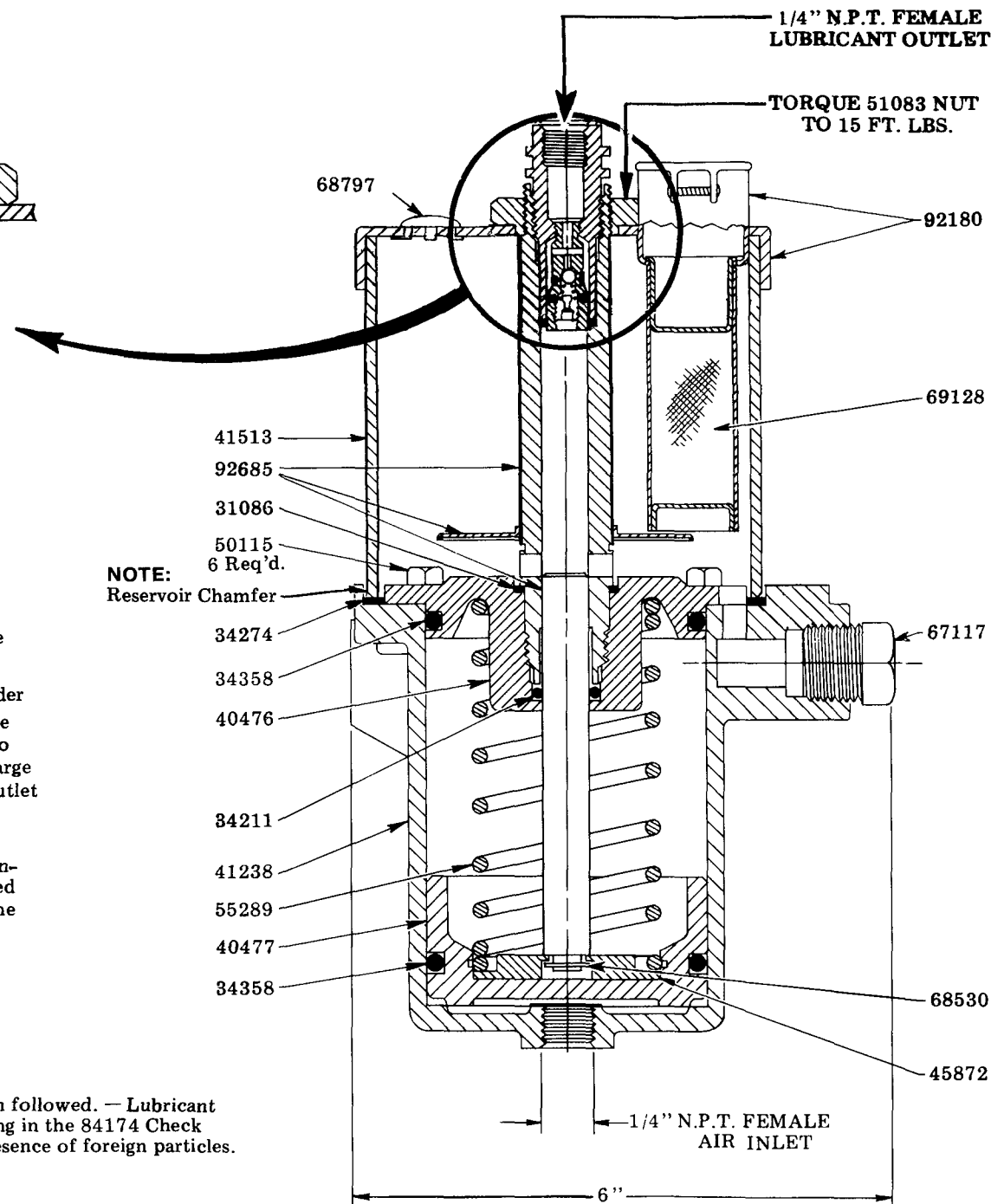

**REPAIR PARTS LIST**

Part No.	Description	Part No.	Description	Part No.	Description
14288	Ball Stop	40476	Cylinder End	67117	Pipe Plug
14290	Check Body	40477	Piston	68530	Retaining Ring
14953	Outlet Body	41238	Cylinder Casting	68797	Plug Button
*31020	Gasket	41513	Reservoir	69128	Strainer
*31086	Gasket	45872	Thrust Washer	69295	Filter
*34211	"O" Ring	50115	Screw	84174	Check Assembly
*34274	Gasket	51083	Nut	92180	Cover Assembly
*34358	"O" Ring	55289	Spring	92685	Bushing and Plunger Assembly
*34368	"O" Ring	*56106	Spring		
*34445	Gasket	*66250	Ball		

\* Parts marked with \* should be kept on hand for replacement purposes.

## TYPES OF INSTALLATIONS

Frequency of lubrication cycle can be controlled mechanically, electrically or manually

### MECHANICAL CONTROL

When using mechanical motion of machine to control lubrication frequency, Three Way Valve is engaged by Cam, permitting air to pass through Valve to Pump, forcing Air Piston forward and lubricant through supply line to Injectors. When the Valve is disengaged, air exhausts back through Valve, and spring in Pump returns Air Piston, completing lubrication cycle. Cam dwell on Three Way Valve must be arranged for a minimum of 10 seconds.

When mechanical motion of machine is too rapid to be used as a source of control for frequency of lubrication cycle, a Cycle Timer with adjustable settings may be used. See separate instructions for Cycle Timers 82701, 82702 and 82703.

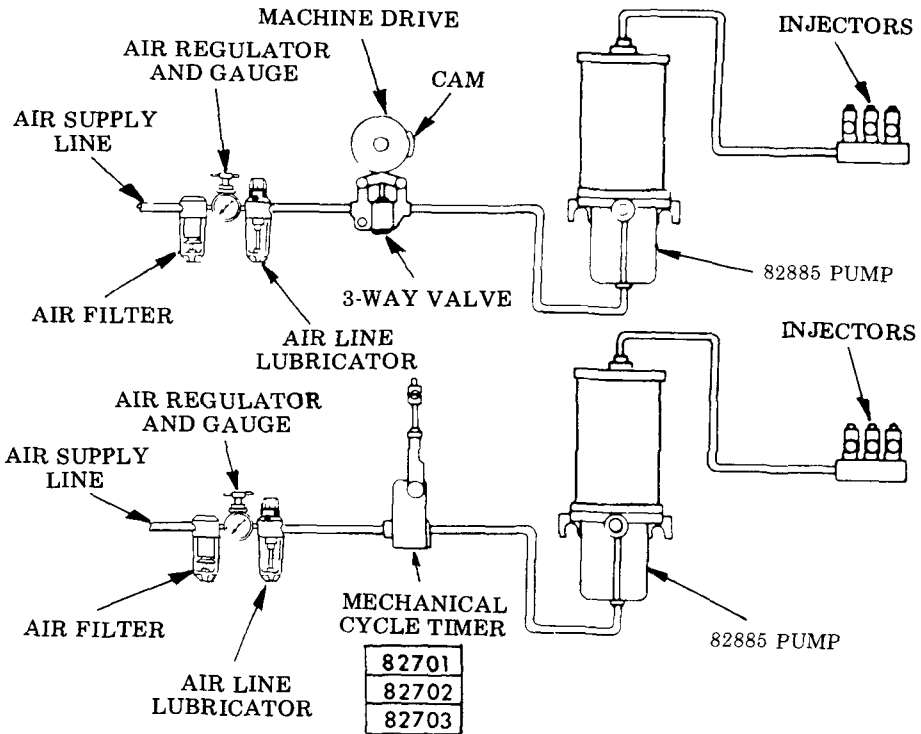

### ELECTRICAL CONTROL

Electrical Time Switch opens Three Way Solenoid Valve, permitting air to flow to Pump forcing Air Piston forward and lubricant through Supply Line to Injectors. When Valve closes, air exhausts back through Valve, and spring in Pump returns Air Piston, completing lubrication cycle. Frequency of cycle can be set as desired by adjustable pins in Time Switch.

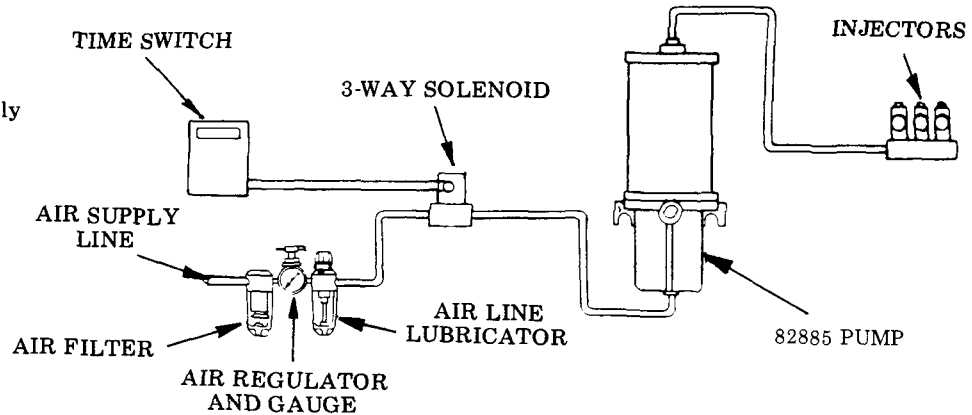

### MANUAL CONTROL

Opening Three Way Valve for a minimum of 10 seconds permits air to flow to Pump forcing Air Piston forward and lubricant through supply line to Injectors. When valve is closed, air exhausts back through Valve, and spring in Pump returns Air Piston, completing lubrication cycle.

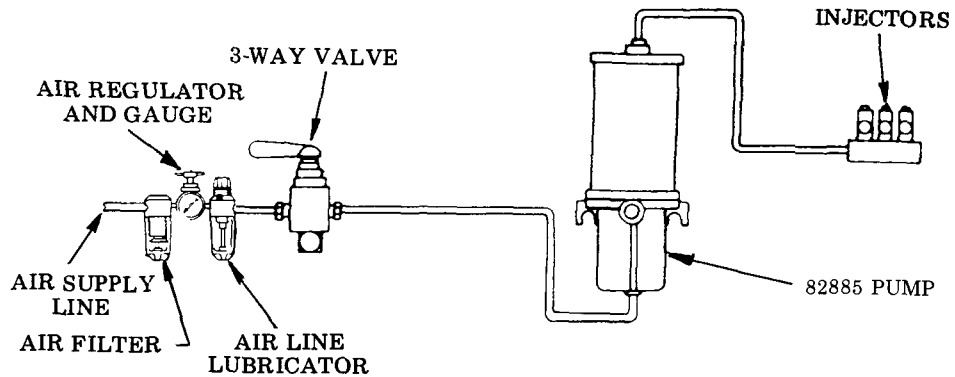

### RETAIN THIS INFORMATION FOR FUTURE REFERENCE

When ordering replacement parts, list: Part Number, Description, Model Number, and Series Letter.

LINCOLN provides a Distributor Network that stocks equipment and replacement parts.