

RATIO	OUTPUT PER STROKE (CU. IN.)	RESERVOIR CAPACITY	AIR INLET	LUBRICANT OUTLET	LUBRICANT OPERATING PRESSURE (PSI)			
					TYPE OF SYSTEM	MINIMUM	MAXIMUM	RECOMMENDED
20:1	* .45	1 lb. (30 cu. in.)	1/4" NPT Female	1/4" NPT Female	SL-32 SL-33	1,200 with 60 PSIG Air	3,500 with 175 PSIG Air	1,500 with 75 PSIG Air

* Based on Lubricants that are free from entrapped air. Lubricants that are aerated will reduce output of pump.

The 82886 Pump is used as the Pumping Unit for a Centralized Lubrication System having a Single Line Circuit of SL-32 or SL-33 Injectors. It is an air-operated, single-stroke, spring-return pump that discharges .450 cu. in. into the circuit for each pump cycle.

The total quantity of lubricant needed for the lubrication cycle of the system must not exceed the lubricant discharged per pump stroke.

TO FILL RESERVOIR

Use Manual Filler Pump 81834 to fill reservoir through the filler fitting in the pump body. Attach coupler on delivery hose to filler fitting. Stroke filler pump handle until lubricant weepage is noted at air vent hole in the reservoir (lower portion of follower must rise beyond air vent hole to expel entrapped air from lubricant). NOTE: When filling the reservoir, caution should be used as extreme pressure can cause damage to reservoir and follower assembly.

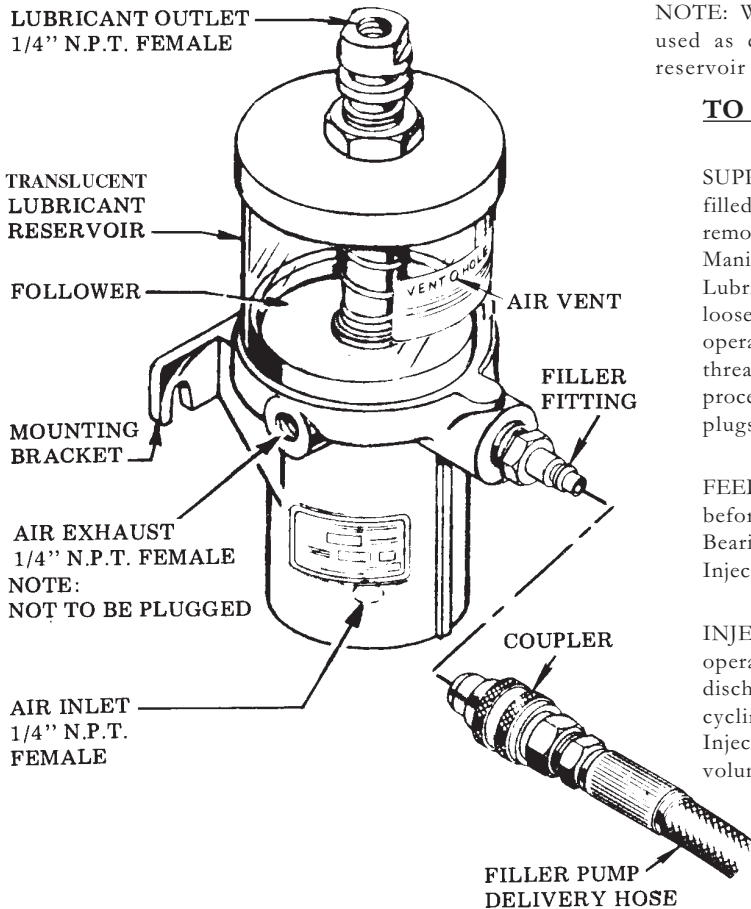

TO PRIME SYSTEM

SUPPLY LINES: After Pump Reservoir has been filled with recommended lubricant, loosen (do not remove) all plugs in dead ends of the Injector Manifolds and Supply Lines. Operate Pump until Lubricant flows from around threads of any loosened plug. Tighten this plug and continue to operate Pump until Lubricant flows from around threads of another loosened plug. Repeat this procedure until all Supply Lines are primed and all plugs are securely tightened.

FEEDER LINES: Fill each Feed Line with Lubricant before connecting lines to outlet of Injectors and Bearings. This will prevent having to cycle each Injector to fill Line between Injector and Bearing.

INJECTORS: Check each Injector for proper operation. Injector Stem moves when Injector discharges Lubricant to Bearing. This may require cycling System several times. After checking Injectors for operation adjust Injectors for the volume required for each Bearing.

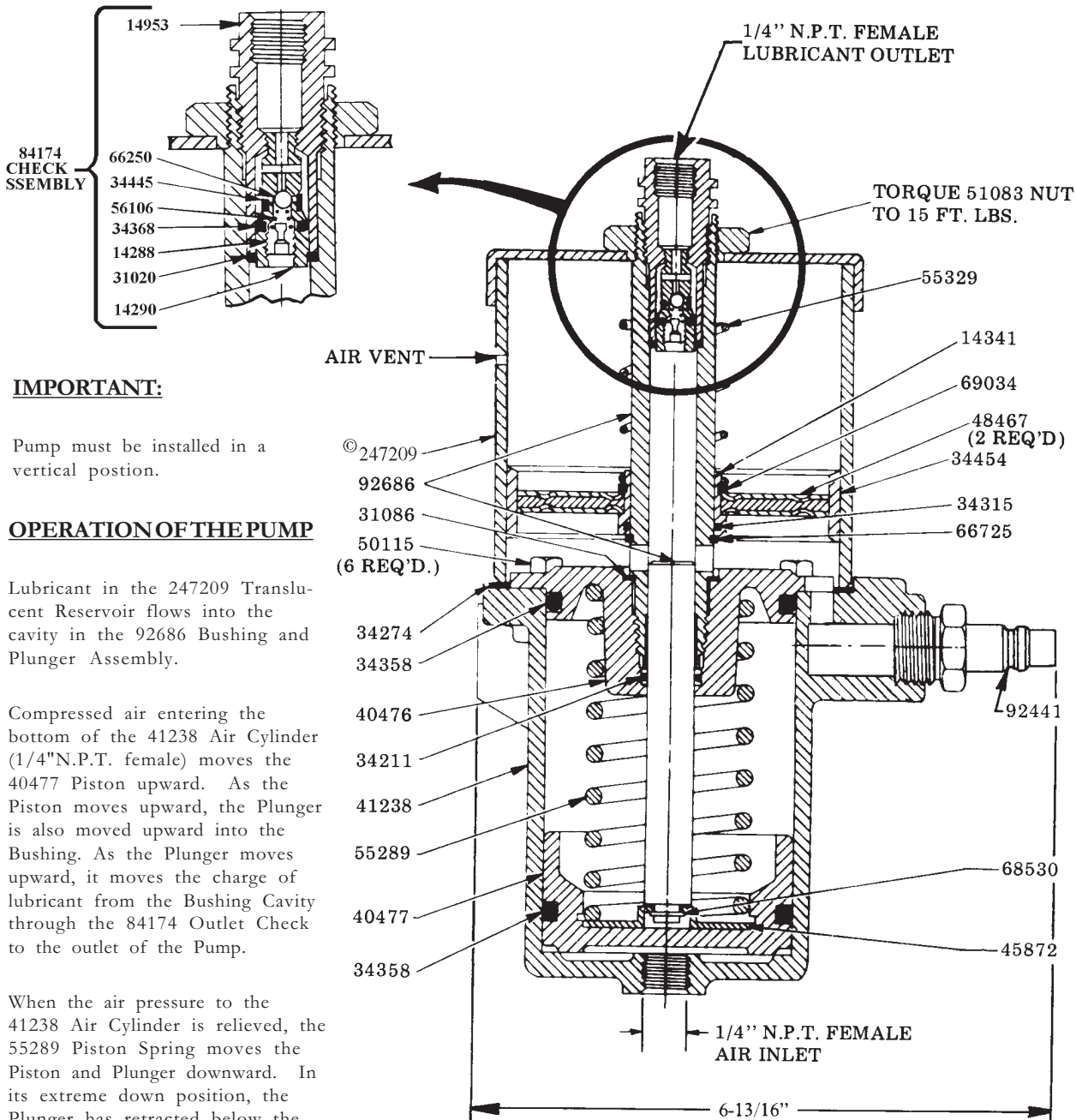

IMPORTANT:

Pump must be installed in a vertical position.

OPERATION OF THE PUMP

Lubricant in the 247209 Translucent Reservoir flows into the cavity in the 92686 Bushing and Plunger Assembly.

Compressed air entering the bottom of the 41238 Air Cylinder (1/4"N.P.T. female) moves the 40477 Piston upward. As the Piston moves upward, the Plunger is also moved upward into the Bushing. As the Plunger moves upward, it moves the charge of lubricant from the Bushing Cavity through the 84174 Outlet Check to the outlet of the Pump.

When the air pressure to the 41238 Air Cylinder is relieved, the 55289 Piston Spring moves the Piston and Plunger downward. In its extreme down position, the Plunger has retracted below the Bushing Port, permitting lubricant to flow into the bushing cavity.

WHAT TO DO IF:

Pump loses prime. - Check lubricant supply.

System fails to cycle and calculated system planning has been followed. - Lubricant may be leaking by the 66250 Ball Check or the 34445 Packing in the 84174 Check and Vent Assembly. Remove these parts and examine for presence of foreign particles. Clean, or replace parts if worn or damaged.

Pump fails to operate. - Check air supply. Failure of Injectors to cycle can be caused by a leak in the supply line.

NOTE: In reassembling the 84174 Check and Extension Assembly, the vent pressure must be reset. Vent pressure can be varied by the Adjusting Screw, 14288. The recommended pressure setting is 25 P.S.I.G. minimum to 75 P.S.I.G. maximum. An improper setting will affect the pump efficiency. Assemble 14288 with non-hardening Loctite or stake threads after adjusting vent pressure.

© Indicates Change

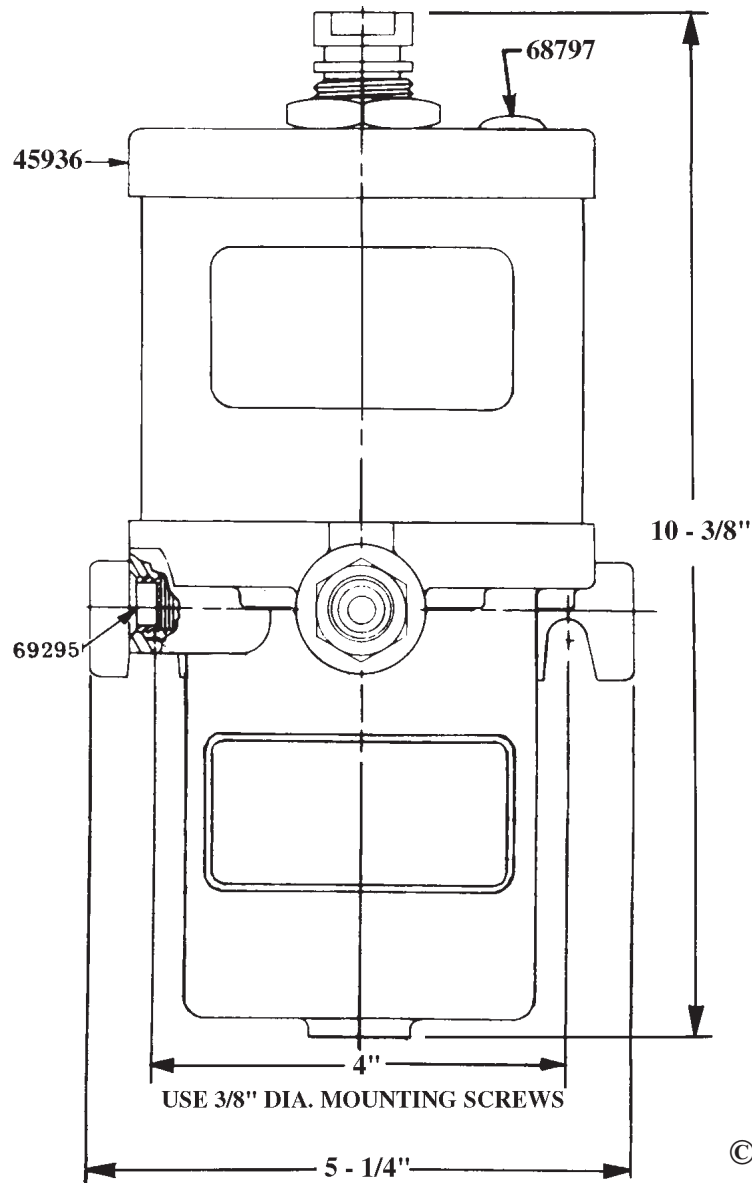

© Indicates Change

SERVICE PARTS

PART NO.	QTY	DESCRIPTION	PART NO.	QTY	DESCRIPTION	PART NO.	QTY	DESCRIPTION
14288	1	Ball Stop	*34445	1	Gasket	55329	1	Spring
14290	1	Check Body	34454	1	Packing (Nitrile)	*56106	1	Spring
14341	1	Bushing	40476	1	Cylinder End	*66250	1	Ball
14953	1	Bushing	40477	1	Piston	66725	1	Retaining Ring
*31020	1	Gasket	41238	1	Cylinder Casting	68530	1	Retaining Ring
*31086	1	Gasket	45872	1	Thrust Washer	68797	1	Plug Button
*34211	1	O-ring (Nitrile)	45936	1	Cover Cap	69034	1	Retaining Ring
*34274	1	Gasket (Neoprene)	48467	2	Washer	*69295	1	Filter
*34315	1	O-ring (Nitrile)	50115	6	Screw	84174	1	Check Assembly
*34358	2	O-ring (Nitrile)	51083	1	Nut	92686	1	Bushing and Plunger Assembly
*34368	1	O-ring (Nitrile)	55289	1	Spring	©247209	1	Reservoir (Acrylic)

* Recommended service part inventory

TYPES OF INSTALLATIONS

Frequency of lubrication cycle can be controlled mechanically, electrically or manually.

MECHANICAL CONTROL

When using mechanical motion of machine to control lubrication frequency, Three Way Valve is engaged by Cam, permitting air to pass through Valve to Pump, forcing Air Piston forward and lubricant through supply line to Injectors. When the Valve is disengaged, air exhausts back through Valve, and spring in Pump returns Air Piston, completing lubrication cycle. Cam dwell on Three Way Valve must be arranged for a minimum of 10 seconds.

When mechanical motion of machine is too rapid to be used as a source of control for frequency of lubrication cycle, a Cycle Timer with adjustable settings may be used. See separate instructions for Cycle Timer 82703.

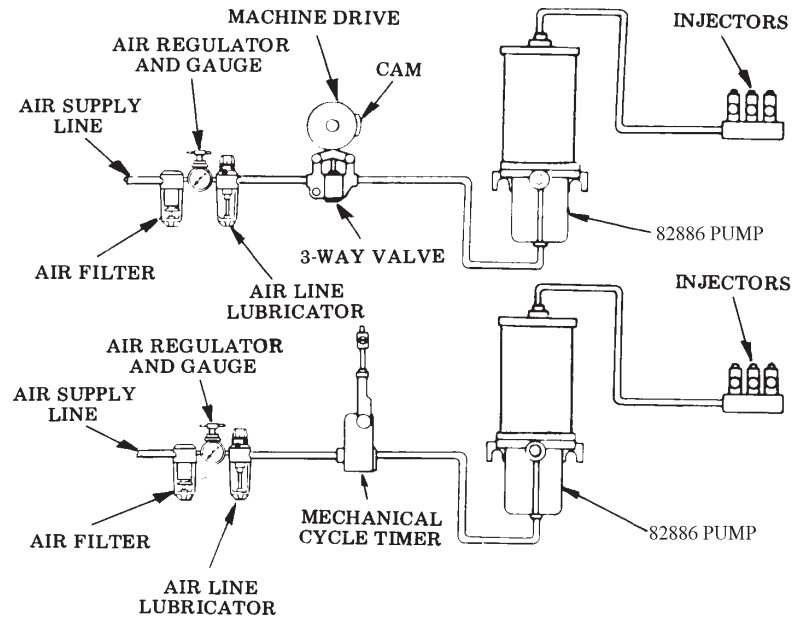

ELECTRICAL CONTROL

Electrical Time Switch opens Three Way Solenoid Valve, permitting air to flow to Pump forcing Air Piston forward and lubricant through Supply Line to Injectors. When Valve closes, air exhausts back through Valve, and spring in Pump returns Air Piston, completing lubrication cycle. Frequency of cycle can be set by Time Switch.

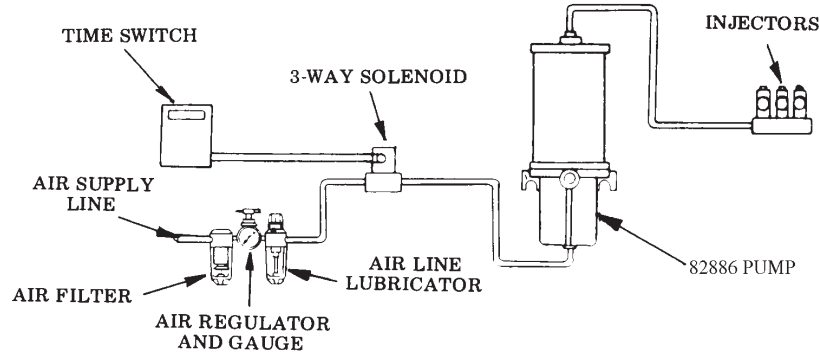

MANUAL CONTROL

Opening Three Way Valve for a minimum of 10 seconds permits air to flow to Pump forcing Air Piston forward and lubricant through supply line to Injectors. When valve is closed, air exhausts back through Valve, and spring in Pump returns Air Piston, completing lubrication cycle.

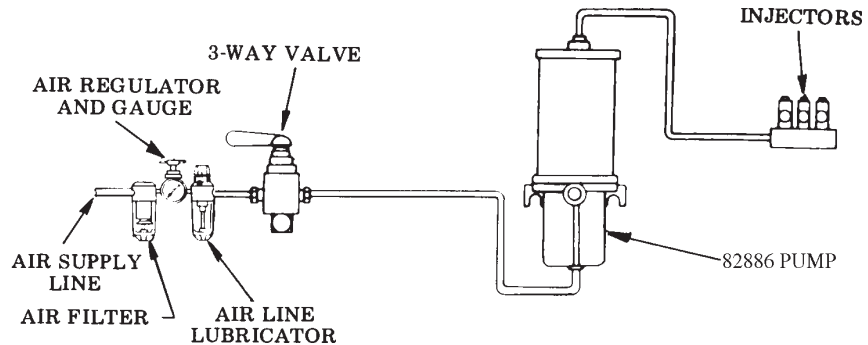

RETAIN THIS INFORMATION FOR FUTURE REFERENCE

When ordering replacement parts, list: Part Number, Description, Model Number and Series Letter.
LINCOLN provides a Distributor Network that stocks equipment and replacement parts.