

AIR OPERATED OIL PUMP

SINGLE STROKE, SPRING RETURN

Model 83841

Series "B"

SPECIFICATIONS

Ratio	Lubricant Output (Cu. In.)	Reservoir Capacity	Air Inlet	Lubricant Outlet	LUBRICANT OPERATING PRESSURE (P.S.I.)			
					Type of System	Minimum	Maximum	Recommended
8:1	*1.6	4-1/4 pints	1/4" N.P.T. Female	1/4" N.P.T. Female	SL-42	750 With 95 P.S.I. Air	1,000 With 125 P.S.I. Air	850 With 110 P.S.I. Air
					SL-43			
					SL-44			

*Based on lubricants that are free of entrapped air. Lubricants that are aerated will reduce output of pump.

The 83841 Pump is used as the pumping unit for a centralized lubrication system having a single line circuit of SL-42, SL-43 and/or SL-44 Injectors dispensing oil.

It is an air operated, single stroke, spring return pump that discharges *1.6 cu. in. of lubricant into the circuit for each pump stroke (Lubrication Cycle).

The total quantity of lubricant needed for the lubrication cycle of the system must not exceed the amount of lubricant discharged per pump stroke.

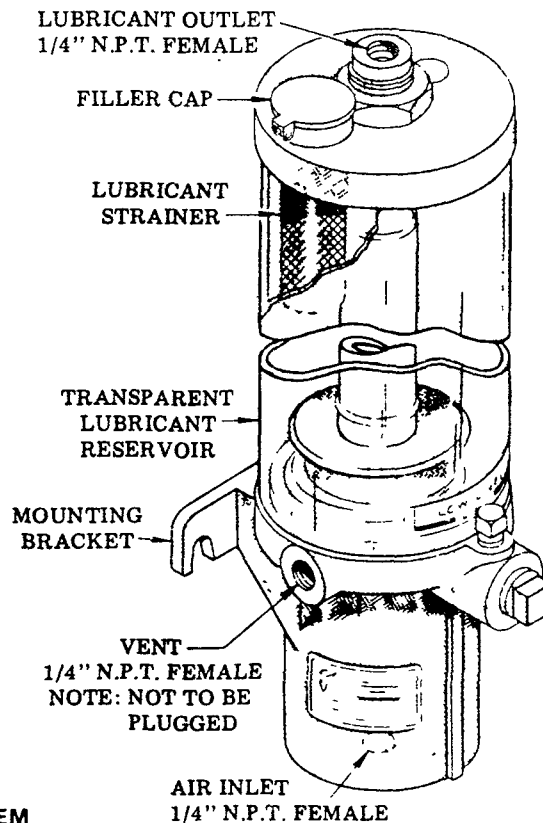

TO FILL RESERVOIR

The reservoir is filled through the filler cap at the top of the reservoir.

A strainer is located at the filler cap to prevent the induction of foreign material into the lubricant reservoir.

Inspect strainer before filling reservoir. When necessary, lift strainer out and clean thoroughly.

TO PRIME SYSTEM

SUPPLY LINES: After pump reservoir has been filled with recommended lubricant, loosen (do not remove) all plugs in dead ends of the injector manifolds and supply lines. Operate pump until lubricant flows from around threads of any loosened plug. Tighten this plug and continue to operate pump until lubricant flows from around threads of another loosened plug. Repeat this procedure until all supply lines are primed.

FEEDER LINES: Fill each feed line with lubricant before connecting lines to outlet of injectors and bearings. This will prevent having to cycle each injector to fill line between injector and bearing.

INJECTORS: Check each injector for proper operation. Injector stem moves when injector discharges lubricant to bearing. This may require cycling system several times. After checking injectors for operation adjust injectors for the volume required for each bearing.

LINCOLN

LINCOLN, One Lincoln Way
St. Louis, Missouri 63120-1578
(314) 679-4200 Customer Service, (314) 679-4300

SECTION - C8
PAGE - 76B

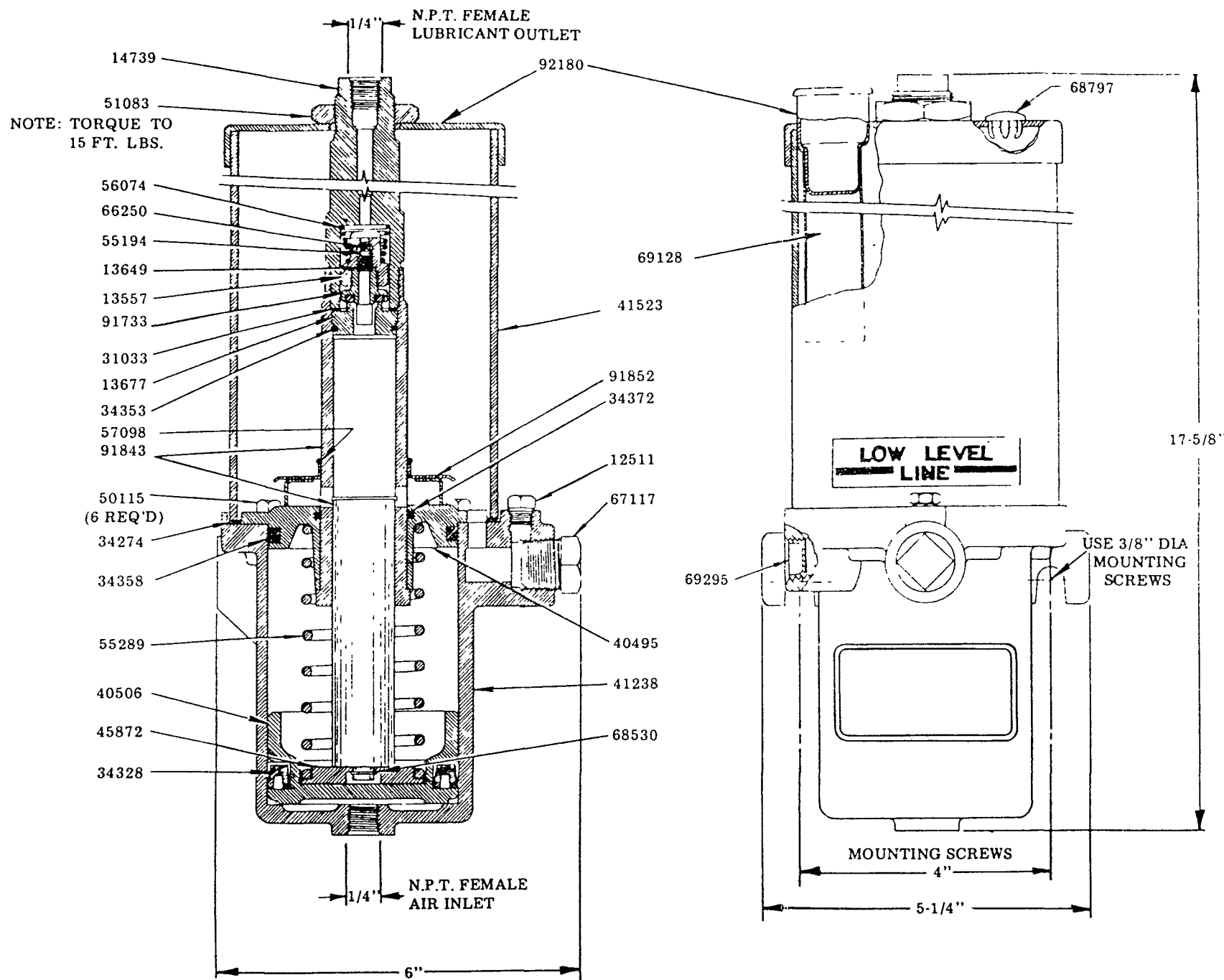

IMPORTANT — Pump must be installed in a vertical position.

OPERATION OF THE PUMP.

Lubricant in the reservoir flows through the cavity in the bushing.

Compressed air entering the bottom of the cylinder moves the piston upward. The plunger, attached to the piston, moves upward into the bushing.

As the plunger moves upward, it forces a charge of lubricant from the bushing cavity into bushing, through the outlet check to the outlet of the pump.

The instant the air pressure entering the air cylinder is relieved, the piston spring moves the piston and plunger downward. In its extreme down position the plunger has retracted below the bushing cavity permitting the cavity to be recharged with lubricant.

WHAT TO DO IF:

PUMP LOSES PRIME — Check lubricant supply.

SYSTEM FAILS TO CYCLE and calculated system planning has been followed — Lubricant is leaking by the 91733 Outlet Check. Remove 91733 Outlet Check and examine packing for presence of foreign particles. If packing is damaged, replace the 91733 Outlet Check.

Remove the 66250 Ball Check, 55194 Spring and 13649 Ball Stop from 13557 Check Retainer. Examine for presence of foreign particles. Clean thoroughly.

Failure of injectors to cycle can also be caused by a leak in the supply line.

Examine supply lines and connections.

PUMP FAILS TO OPERATE — Check air supply.

SERVICE PARTS

PART NO.	DESCRIPTION	PART NO.	DESCRIPTION	PART NO.	DESCRIPTION
12511	Pipe Plug	40495	Cylinder End	66250	5/32" Dia. Steel Ball
13557	Check Retainer	40506	Piston	67117	Pipe Plug
13649	Ball Stop	41238	Cylinder	68530	Tru-Arc
13677	Check Seat	41523	Reservoir Assembly	68797	Plug Button
14739	Outlet Bushing	45872	Thrust Washer	69128	Strainer
*31033	Gasket	50115	Machine Screw	69295	Filter
*34274	Gasket	51083	Nut	*91733	Check Assembly
*34328	Block Vee-Packing	55194	Spring	91843	Bushing and Plunger Assembly
*34353	O-Ring	55289	Spring	91852	Baffle Assembly
*34358	O-Ring	*56074	Spring	92180	Cover Assembly
*34372	O-Ring	57098	Ring Spring		

*Recommended service parts inventory.

TYPES OF INSTALLATIONS

Frequency of lubrication cycle can be controlled Mechanically, Electrically or Manually

MECHANICAL CONTROL

When using mechanical motion of machine to control lubrication frequency, three way valve is engaged by cam permitting air to pass through valve to pump forcing air piston forward and lubricant through supply line to injectors. When the valve is disengaged, air exhausts back through valve and spring in pump returns air piston completing lubrication cycle. Cam dwell on three way valve must be arranged for a minimum of 10 seconds.

When mechanical motion of machine is too rapid to be used as a source of control for frequency of lubrication cycle, a cycle timer with adjustable settings may be used. See separate instructions for Cycle Timers 82701, 82702 and 82703, Section C8 — Page 60.

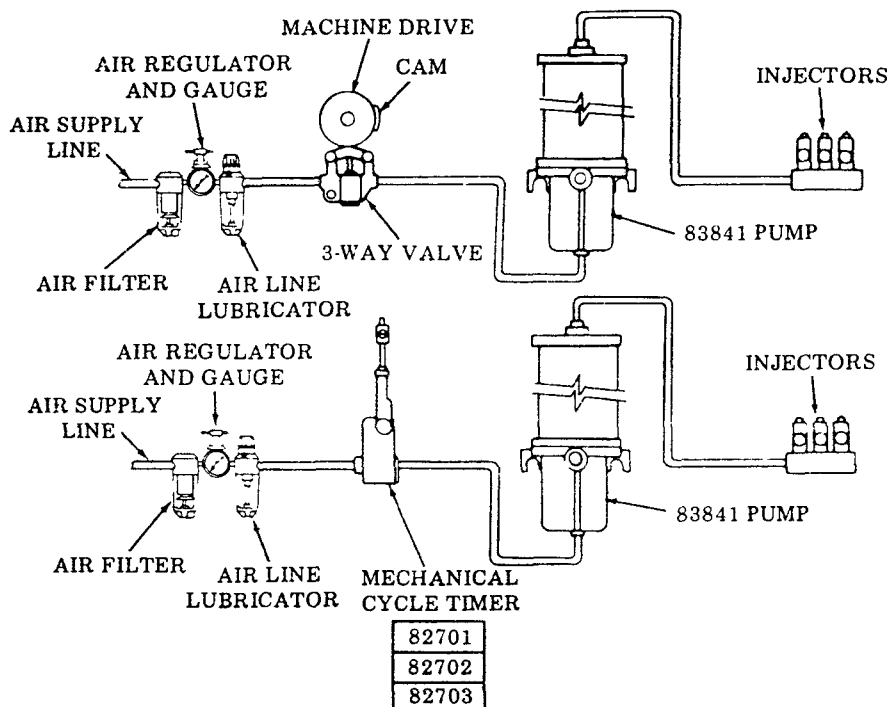

ELECTRICAL CONTROL

Electrical time switch opens three way solenoid valve permitting air to flow to pump forcing air piston forward and lubricant through supply line to injectors. When valve closes, air exhausts back through valve and spring in pump returns air piston completing lubrication cycle. Frequency of cycle can be set as desired by adjustable pins in time switch.

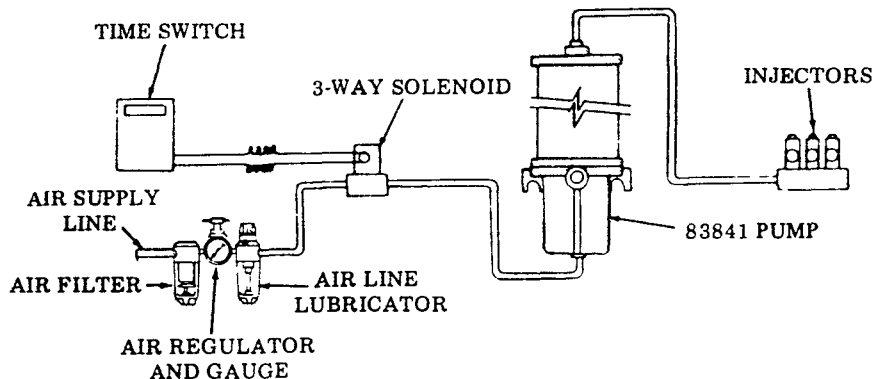

MANUAL CONTROL

Opening three way valve for a minimum of 10 seconds permits air to flow to pump forcing air piston forward and lubricant through supply line to injectors. When valve is closed, air exhausts back through valve and spring in pump returns air piston completing lubrication cycle.

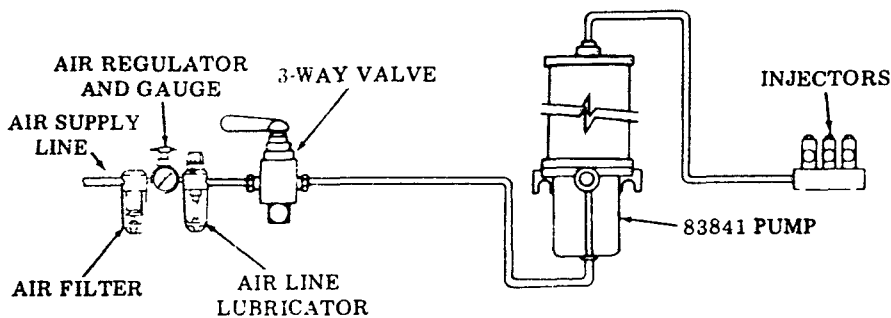

— RETAIN THIS INFORMATION FOR FUTURE REFERENCE —

When ordering replacement parts, list: Part Number, Description, Model Number, and Series Letter.

LINCOLN ST. LOUIS provides a Distributor Network that stocks equipment and replacement parts.

A list of Authorized Service Departments will be furnished upon request.