

RATIO	LUBRICANT OUTPUT (cu. in.)		RESERVOIR CAPACITY	AIR INLET	LUBRICANT OUTLET	LUBRICANT OPERATING PRESSURE (PSI)			
	PER CYCLE	PER MIN.				TYPE OF SYSTEM	MINIMUM	MAXIMUM	RECOM- MENDED
40:1	*.11	12	12 LBS.	1/8" NPTF	3/4" NPTF	SL-1 SL-11	1850	3500	2500
						SL-32 SL-33	1200	3500	1500

**TYPICAL
INSTALLATION**

The 83167 Pump is used as the pumping unit for a centralized lubrication system having a single line circuit of SL-1, SL-11, SL-32, or SL-33 Injectors.

It is an air operated reciprocating pump that discharges an established amount of lubricant *(.11 cu. in.) into the circuit for each pump cycle.

* Based on lubricants that are free of entrapped air. Lubricants that are aerated will reduce output of pump.

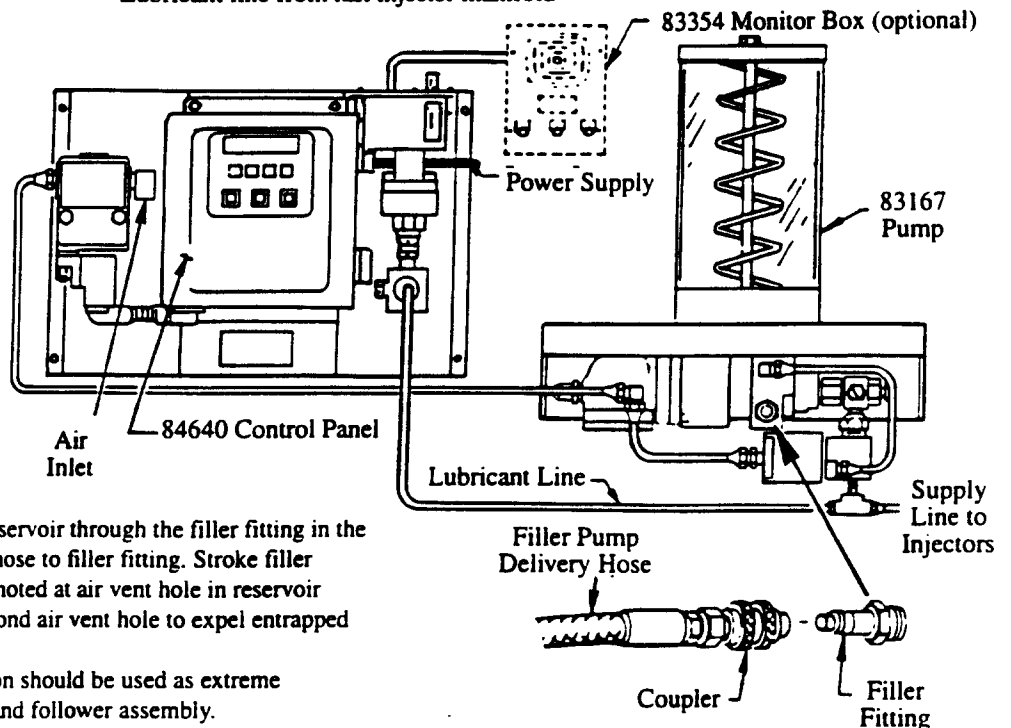
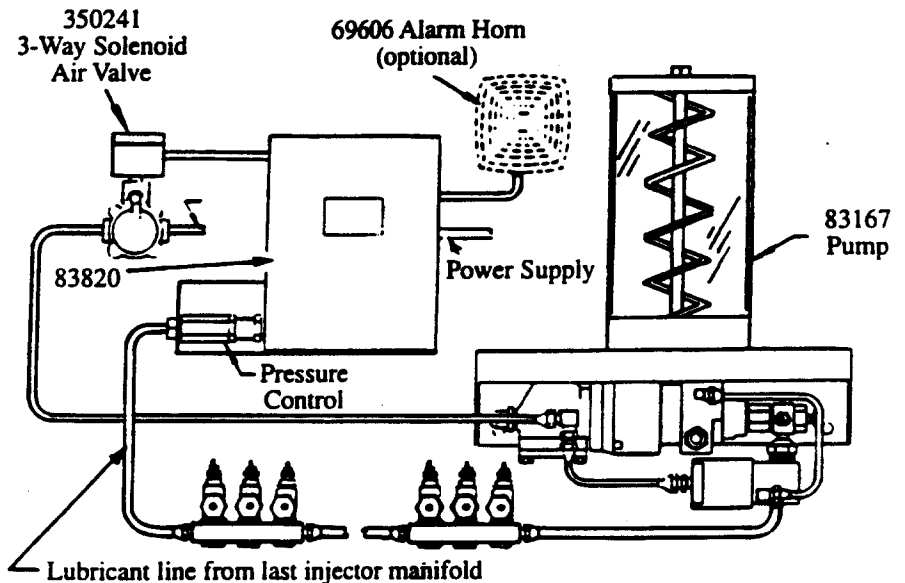

TO FILL RESERVOIR

Use 81834 Manual Filler Pump to fill reservoir through the filler fitting in the pump body. Attach coupler on delivery hose to filler fitting. Stroke filler pump handle until lubricant weepage is noted at air vent hole in reservoir (lower portion of follower must rise beyond air vent hole to expel entrapped air from lubricant).

NOTE: When filling the reservoir, caution should be used as extreme pressure can cause damage to reservoir and follower assembly.

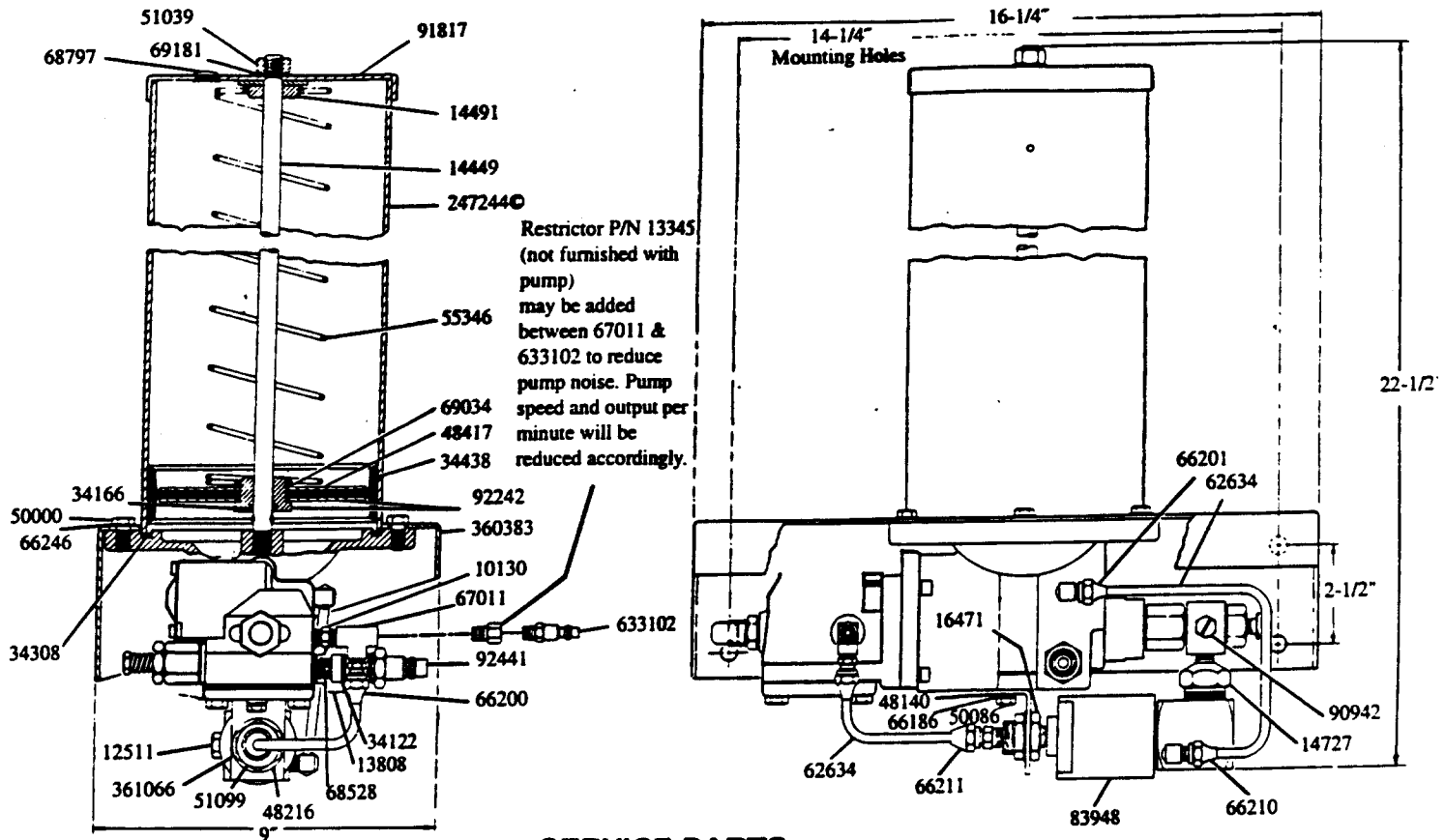

SERVICE PARTS

Part	Qty.	Description	Part	Qty.	Description	Part	Qty.	Description
*10061	1	Pump check disc	*34158	1	Gasket (Neoprene)	67011	1	Tee
10127	1	Plug	34166	1	O-ring (Nitrile)	68538	1	Strainer
10130	1	Nipple	*34229	1	Packing (Nitrile)	68797	1	Plug button
11470	1	Cap	34308	1	Gasket (Nitrile)	69034	1	Retaining ring
*11471	1	Trip rod collar	34314	1	O-ring (Nitrile)	69181	1	Lockwasher
*11472	1	Trip rod pin	34438	1	Follower	*83063	1	Valve slide, seat & gasket assy.
*11475	1	Trip shoe	*38162	1	Valve gasket (Nitrile)	83946	1	Vent valve assembly
11904	1	Packing nut	40821	1	Base casting	84508	1	Bushing, plunger & O-rng assy.
11905	1	Packing cap	*45605	1	Valve guide plate	*90770	1	Trip rod
*11947	1	Trip sleeve	48140	1	Washer	*90942	1	Safety unloader
12093	1	Check housing	48212	2	Washer	*91331	1	Toggle plate
12094	1	Air piston bolt	48216	1	Washer	91817	1	Reservoir cap
12095	1	Outlet body	48237	1	Washer	92242	1	Bushing & washer assembly
12096	1	Outlet block	48417	1	Follower washer	92441	1	Filter fitting
12511	2	Pipe plug	50000	6	Screw	236286	1	Cover
12834	1	Spring retainer	50086	1	Bolt	236615	1	Muffler cover
13808	1	Adapter	50521	4	Screw	*236616	1	Gasket
14449	1	Tie rod	51039	1	Nut	236833	1	Muffler
14491	1	Retainer washer	51099	1	Nut	*236835	1	Packing
14720	1	Air cylinder	55138	4	Spring	236868	4	Screw
14721	1	Piston	55231	1	Spring	236869	6	Screw
*14722	1	Needle	55346	1	Follower spring	236870	4	Valve seat bolt
*14723	1	Valve seat	56003	1	Spring	237562	1	Air valve casting
14727	1	Reducer nipple	56038	2	Spring	239330	1	Viton packing assembly
16471	1	Support adapter	62632	1	Steel tubing	239336	1	Valve body
30003	1	Gasket	62634	1	Aluminum tubing	*244313	1	Seat
*31007	2	Gasket	66002	1	Steel ball	*244359	1	O-ring (Nitrile)
31047	2	Gasket	*66010	2	Steel ball	*245425	1	Trip rod packing nut
31054	1	Gasket	66186	1	Lockwasher	0246816	1	Gasket
31056	1	Gasket	66200	1	Straight tube connector	0247244	1	Reservoir (acrylic)
*33014	1	Gasket	66201	1	90° tube connector	360383	1	Base
34090	1	Packing (Nitrile)	66210	1	90° tube connector	361066	1	Bracket
*34110	1	Packing (Nitrile)	66211	1	Straight tube connector	633102	1	Plug
*34122	1	Check disc packing	66246	6	Lockwasher			

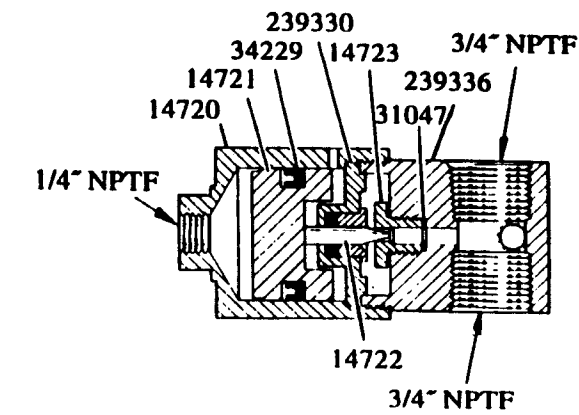
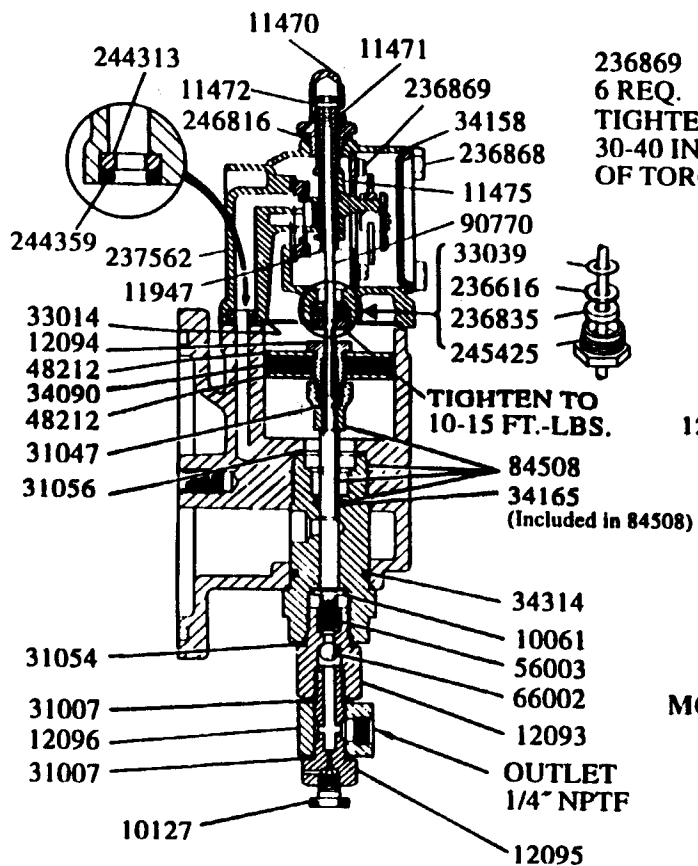

83948 VENT VALVE

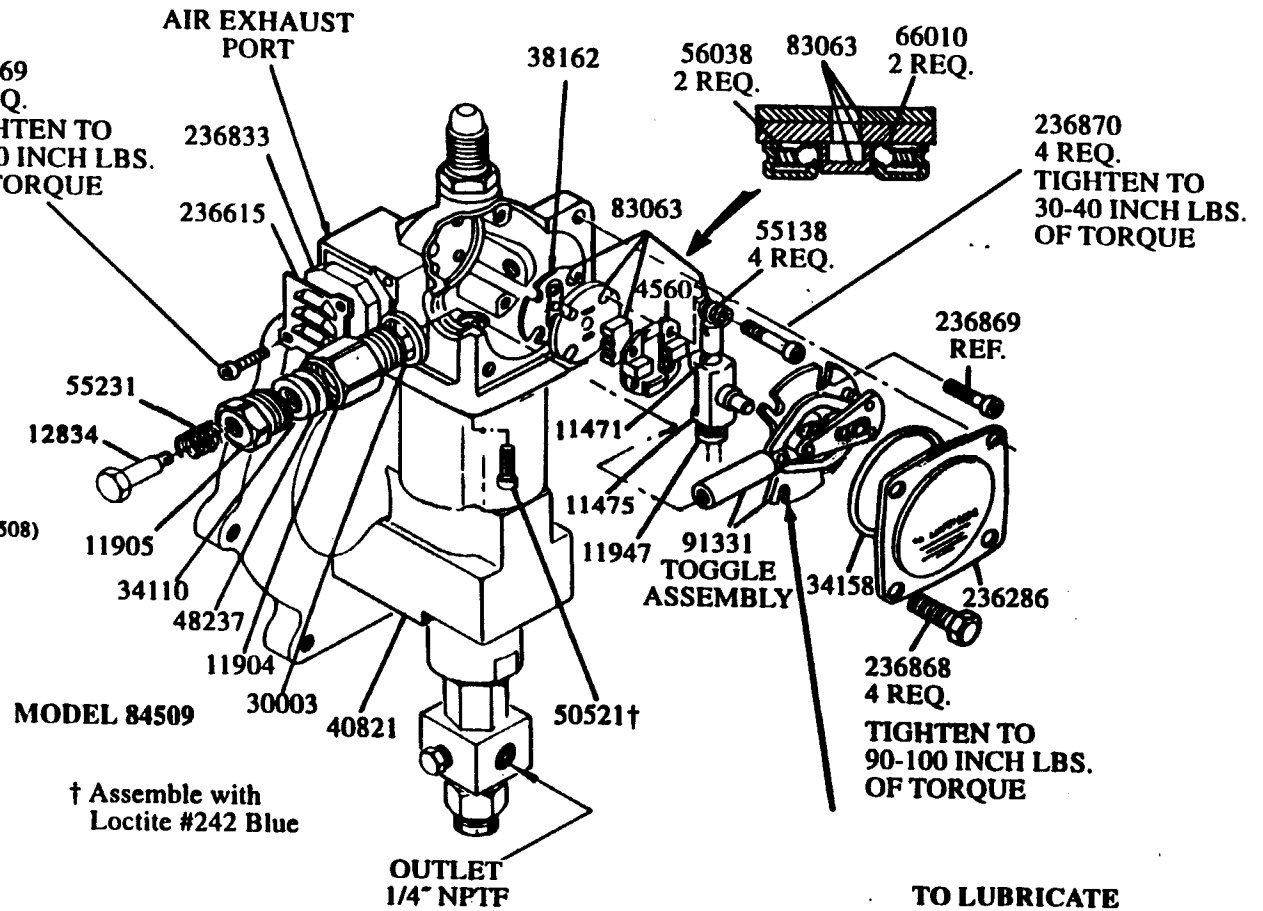

† Assemble with Loctite #242 Blue

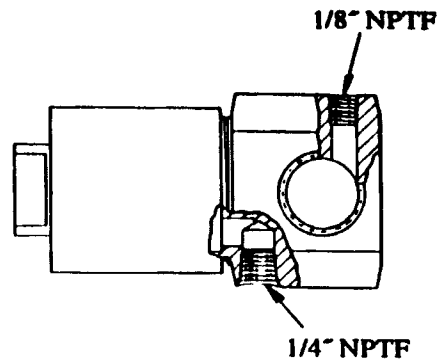

© INDICATES CHANGE

IMPORTANT – Start fasteners by hand to avoid stripping threads when re-assembling.

TO LUBRICATE AIR VALVE MECHANISM

Disconnect air to pump, remove the four cover screws, cover plate and cover plate gasket.

Remove and disassemble the air valve casting from the pump.

The air valve casting should be cleaned or flushed to remove any chips, or other foreign particles prior to re-assembly.

Before replacing the toggle assembly, pack cavity with grease.

Use NLGI No. 1 (light grade) water repellent grease. Approximately 1 1/2 ounces.

Replace cover gasket, cover, and screws. Tighten to avoid air leaks.

Periodic inspection of parts at least once each year as is advisable.

INSTRUCTIONS FOR PUMP USING 84640 CONTROL PANEL

TO PRIME SYSTEM

SUPPLY LINES:

After pump reservoir has been filled with recommended lubricant, loosen all plugs in dead ends of injector manifolds and supply lines. Turn vent plug in pump counter-clockwise one complete turn. Depress manual lube pushbutton on door to start pump. Operate pump until lubricant bleeds around vent plug to expel air pockets trapped between the pump and the supply line connection. Tighten vent plug. Continue operating pump until lubricant flows around any plug. Tighten plug. Repeat this procedure until all plug openings are tight and supply lines are primed. Turn off power to reset controller.

IMPORTANT:

Refer to Owner/Operator Manual C8 247-1 to program controller on 84640.

FEEDER LINES:

Fill each feed line with lubricant before connecting lines to outlets of injectors

and bearings. This will prevent having to cycle each injector to fill the feed line between injectors and bearing.

INJECTORS:

Check the injectors for proper operation by observing the movement of the indicator stems.

OPERATION:

When model 84530 times out it will initiate a lube cycle. The air solenoid is energized to deliver air to the pump and air to the vent valve. Pump begins dispensing lubricant through injectors to the bearings.

When all bearings have received lubricant, pressure rises in system to actuate pressure switch. When pressure switch actuates, the control is reset to de-energize solenoid valve cutting off air to pump and vent valve. Pump stops, pressure vents and pressure switch de-actuates. Control begins timing toward next lube event.

INSTRUCTIONS FOR PUMP USING 83820 TIME CONTROL

TO PRIME SYSTEM

SUPPLY LINES:

After pump reservoir has been filled with recommended lubricant, loosen all plugs in dead ends of injectors manifolds and supply lines. Turn vent plug in pump counter-clockwise one complete turn. Set the delay relay to its maximum position (Refer to Service Manual Section C8, Page 133 Series). Depress push button on top of time control to start pump. Operate pump until lubricant bleeds around vent plug to expel air pockets trapped between the pump and the supply line connection. Tighten vent plug. Continue operating pump until lubricant flows around any plug. Tighten plug. Repeat this procedure until all plug openings are tight and supply lines are primed. Open line switch to shut off pump.

IMPORTANT:

Reset the delay relay to desired interval (Refer to System Planning Manual).

FEEDER LINES:

Fill each line with lubricant before connecting lines to outlets of injectors and bearings. This will prevent having to cycle each injector to fill the feed line between injector and bearing.

INJECTORS:

Check injectors for proper operation by observing the movement of the indicator stems.

OPERATION

The timer (runs constantly when current is on), drives a cam which has lobes set for the desired lubrication cycle frequency (Refer to Service Manual Section C8, Page 133 Series). Lobes engage the micro-switch lever arm to activate the switch, closing the circuit to open the 3-way solenoid air valve permitting air to operate the pump. The pump discharges lubricant through the supply line to the injectors. After the injectors operate (discharge lubricant to the bearings), pump continues to build up lubricant pressure in the supply line until sufficient to operate the pressure control which moves a switch plate, breaking the circuit to the 3-way solenoid air valve, shutting off the air to the pump. Injectors automatically re-charge with lubricant and system is ready for the next lubrication cycle.

The pressure control is factory set for 2,500 psi, adequate for any normal installation. If higher pressure is necessary (2,900 psi maximum), the pressure control can be reset:

- 1) Loosen locknut.
- 2) Turn the housing clockwise into the pressure control body until proper pressure is obtained.
- 3) Tighten locknut.

To lower pressure (1,500 psi minimum):

- 1) Loosen locknut.
- 2) Turn the housing counter-clockwise into the pressure control body until proper pressure is obtained.
- 3) Tighten locknut.

VENT VALVE:

The 83948 Vent Valve is operated by compressed air from the same source which operates the pump. When pump is in operation, air pressure keeps the vent valve closed and lubricant is directed through the outlet and to the injectors. When air to the pump is shut off, vent valve opens and supply line pressure vents back into the reservoir.

SAFETY UNLOADER:

90942 Safety unloader is provided at the pump outlet to prevent the build-up of dangerously high lubricant pressure in the system. It is factory set to open at approximately 3,750 psi to 4,250 psi.

NOTE: Safety unloader requires no adjustment and should not be tampered with.

WHAT TO DO IF:

Pump loses prime: Check lubricant supply.

10127 Vent Plug is provided at the pump outlet for expelling air which may be pocketed in the lubricant. If pump operated continuously without discharging lubricant, it is an indication that the pump has lost its prime. Loosen the vent plug one turn until trapped air is pumped out. If pump continues to operate without discharging lubricant, 10061 Pump Check and 66002 Steel Ball may be fouled. Remove and clean checks and check seats. The 83948 Vent Valve may also be fouled. Foreign material may prevent 14722 Needle from seating properly or 14723 Valve Seat may be worn or damaged. Clean or replace parts.

Failure of injectors to cycle can also be caused by a leak in the supply line. Examine lines and connections.

Pump fails to operate: Check air supply.

RETAIN THIS INFORMATION FOR FUTURE REFERENCE

When ordering replacements parts, list: Part number, Description, Model Number, and Series Letter.

LINCOLN provides a Distributor Network that stocks equipment and replacement parts.