

SINGLE AND MANIFOLD TYPE
For Dispensing Fluid Lubricant and Grease
Not to Exceed N.L.G.I. #1 Grade

SPECIFICATIONS

Minimum operating pressure - 1,850 PSI.
Maximum operating pressure - 3,500 PSI.
Recommended operating pressure - 2,500 PSI.
Maximum vent (Recharge) pressure - 600 PSI.
Lubricant output is adjustable from .008 cu. in. to .08 cu. in.
Injectors can be mounted in any position and can be used
in circuits with SL-32 and/or SL-33 Injectors.

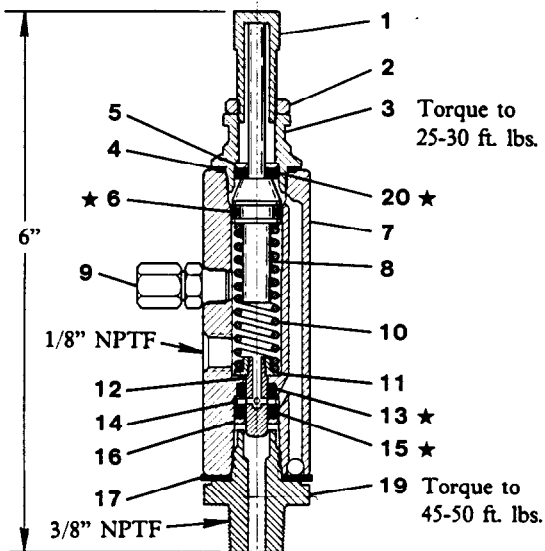

MODEL 81713
SINGLE UNIT INJECTOR

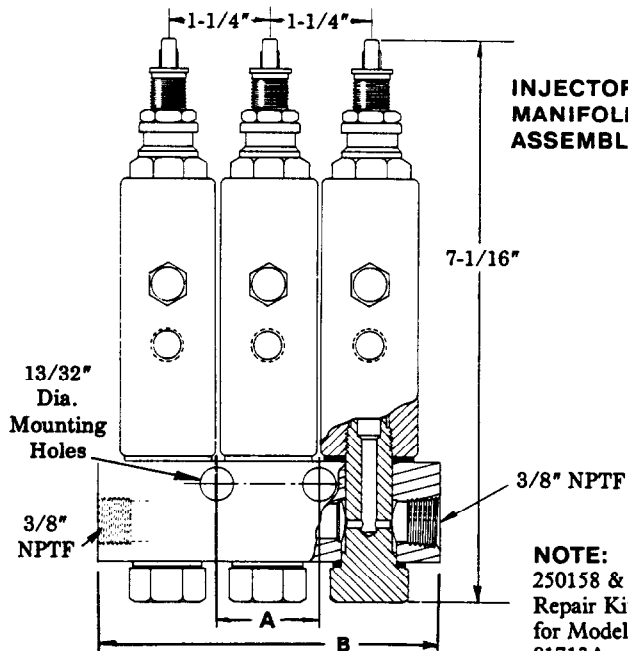

INJECTOR
MANIFOLD
ASSEMBLY

NOTE:
250158 & 246000
Repair Kits available
for Models 81713 &
81713A.

SERVICE PARTS

Item No.	Description	Qty.	Part No.
1	Adjusting screw	1	11623
2	Lock nut	1	11624
3	Piston stop plug	1	11450
4	Gasket	2	•
5	Washer	1	•
6	Viton o-ring	1	•★
7	Injector body assembly	1	241427
8	Piston assembly	1	•
9	Fitting assembly	1	90471
10	Plunger spring	1	•
11	Spring seat	1	•
12	Plunger	1	•
13	Viton packing	1	•★
14	Inlet disc	1	•
15	Viton packing	1	•★
16	Washer	1	•
17	Gasket	1	31064
18	Adapter bolt	1	11961
19	Adapter	1	13216
20	Viton packing	1	•★

• Included in 250158 Repair Kit.
© ★ Included in 246000 Soft Parts Kit.

MANIFOLD TYPE INJECTORS

Model	Type	Dim. A	Dim. B	Manifold
81770-1	Single injector manifold	**	2-1/2"	12658
81770-2	Two injector manifold	**	3"	11962
81770-3	Three injector manifold	1-1/4"	4-1/4"	11963
81770-4	Four injector manifold	2-1/2"	5-1/2"	11964
81770-5	Five injector manifold	3-3/4"	6-3/4"	11965

** Single mounting hole.

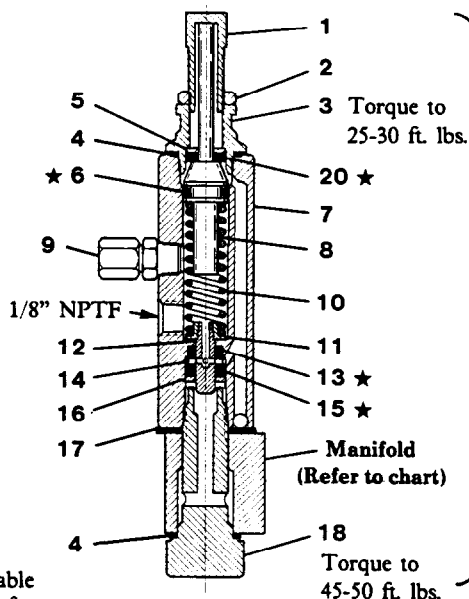

81713A
REPLACEMENT
INJECTOR
ASSEMBLY

© Indicates Change

OPERATION

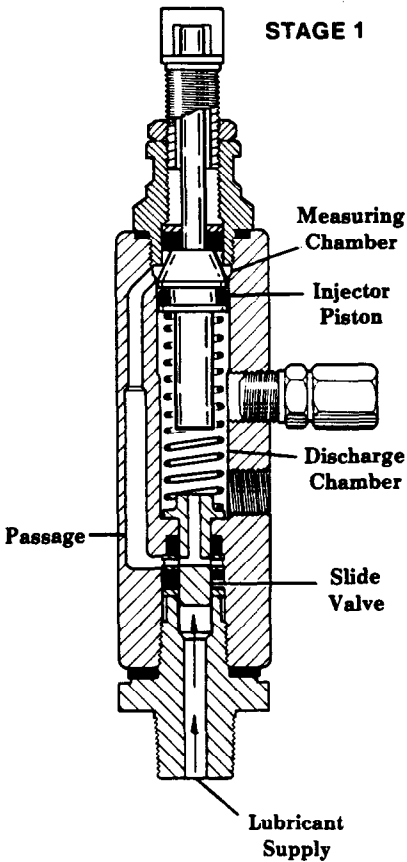

STAGE 1

The injector piston is in its normal or rest position. The discharge chamber is filled with lubricant from the previous cycle. Under the pressure of incoming lubricant, the slide valve is about to open the passage leading to the measuring chamber above the injector piston.

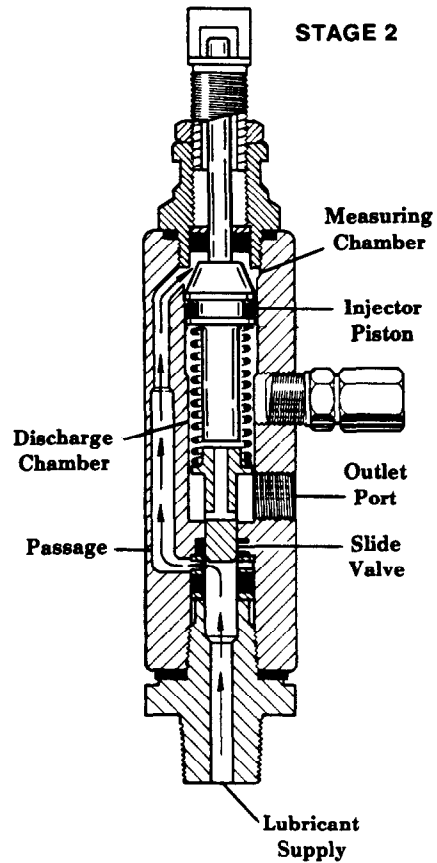

STAGE 2

When the slide valve uncovers the passage, lubricant is admitted to the measuring chamber above the injector piston which forces lubricant from the discharge chamber through the outlet port to bearing.

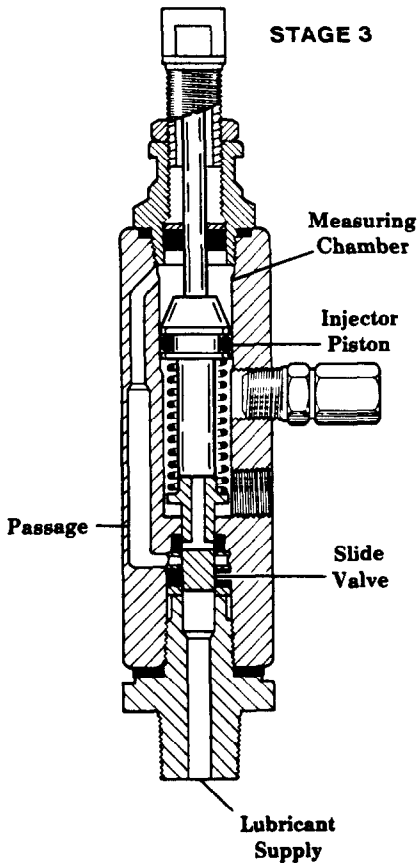

STAGE 3

As the injector piston completes its stroke, it pushes the slide valve past the passage, cutting off further admission of lubricant to the passage and measuring chamber. The injector piston and slide valve remain in this position until lubricant pressure in the supply line is vented (relieved at the pump).

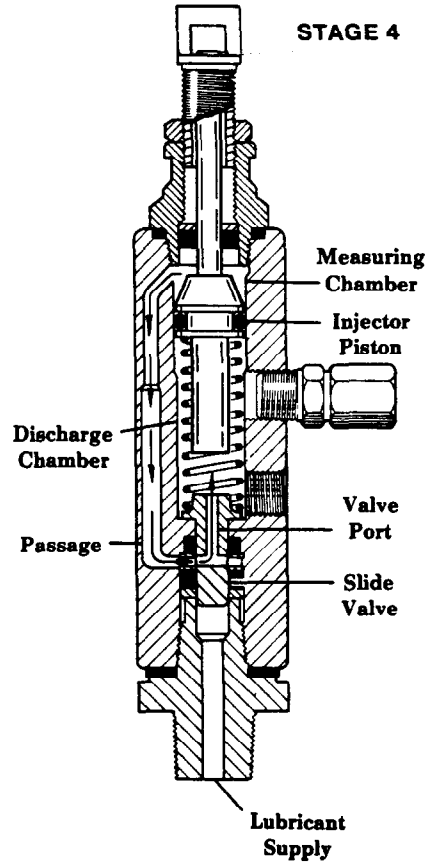

STAGE 4

After venting, the injector spring expands, causing the slide valve to move, so that the passage and discharge chamber are connected by a valve port. Further expansion of the spring causes the piston to move upward, forcing the lubricant in the measuring chamber through the passage and valve port to refill the discharge chamber.

Injector is now ready for next cycle.

RETAIN THIS INFORMATION FOR FUTURE REFERENCE

When ordering replacement parts, list: Part Number, Description, Model Number, and Series Letter.

LINCOLN provides a Distributor Network that stocks equipment and replacement parts.