

FOR DISPENSING OIL ONLY SPECIFICATIONS

OUTPUT:.....Adjustable from .001 cu. in. to .008 cu. in.
 OPERATING PRESSURE:.....750 psi to 1000 psi
 RECOMMENDED OPERATING PRESSURE:.....850 psi
 RECHARGE PRESSURE:.....150 psi
 May be used in a system with SL-41, SL-42, or SL-44 Injectors.

MANIFOLD CHART

Model	Description	Dimensions		Manifold
		A	B	
83661-1	1 Unit	1-1/4"	1-3/4"	91883-1
83661-2	2 Unit	2"	2-1/2"	91884-1
83661-3	3 Unit	2-3/4"	3-1/4"	91885-1
83661-4	4 Unit	3-1/2"	4"	91886-1

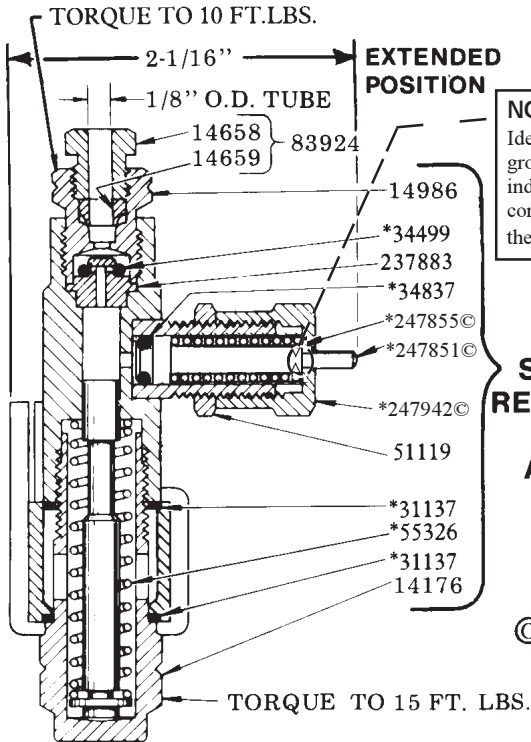

NOTE:
Identification groove on piston indicator corresponds to these models only.

MODEL 83660 SERIES "D" REPLACEMENT INJECTOR ASSEMBLY

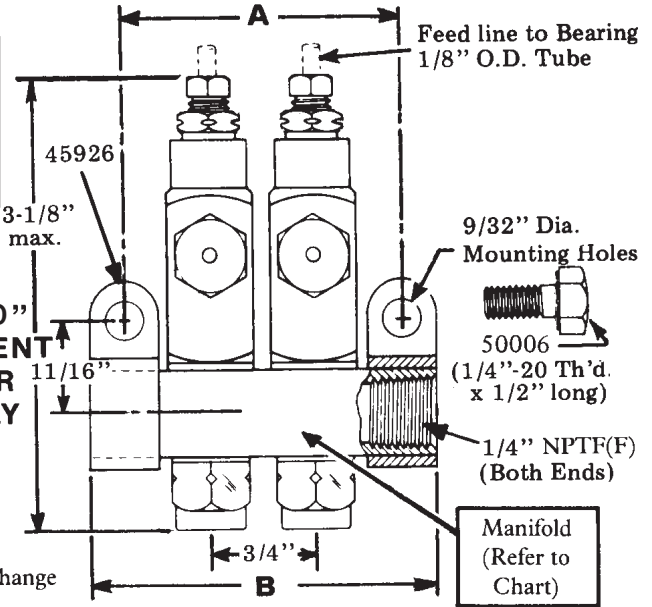

SERVICE PARTS

Model	Qty.	Description
13889	1	Injector inlet
14176	1	Adapter
14658	1	Compression nut
14659	1	Ferrule
14986	1	Outlet body
31100	1	Gasket
+*31137	2	Gasket
+*34499	2	O-ring (Nitrile)
+*34837	1	Packing (Nitrile)
45926	2	Manifold clip
50006	2	Mounting screw
51119	1	Lock nut
+*55326	1	Spring
83924	1	Compression nut assembly
+*237883	1	Check seat
+247851	1	Indicator
+*247855	1	Spring
+ 247942	1	Injector Cap

NOTE: Injectors from previous series can be improved with stenciled cap and single piece piston by use of 247955 upgrade kit.

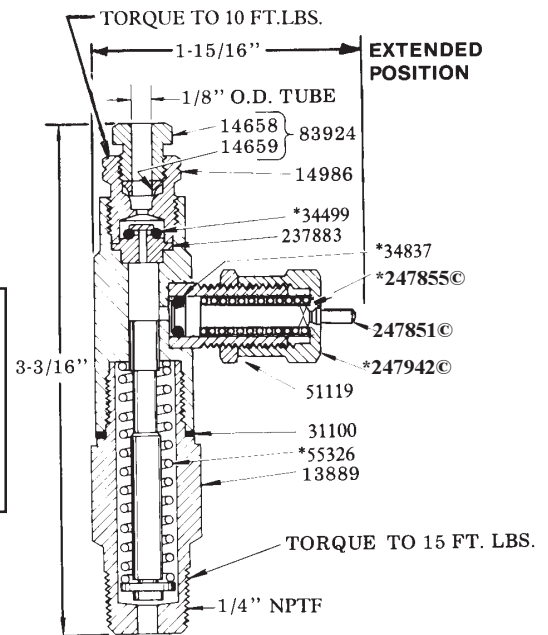

MODEL 83662 SERIES "D" SINGLE TYPE INJECTOR

* Included in 247962 Repair Kit

+ Included in 247955 Upgrade Kit

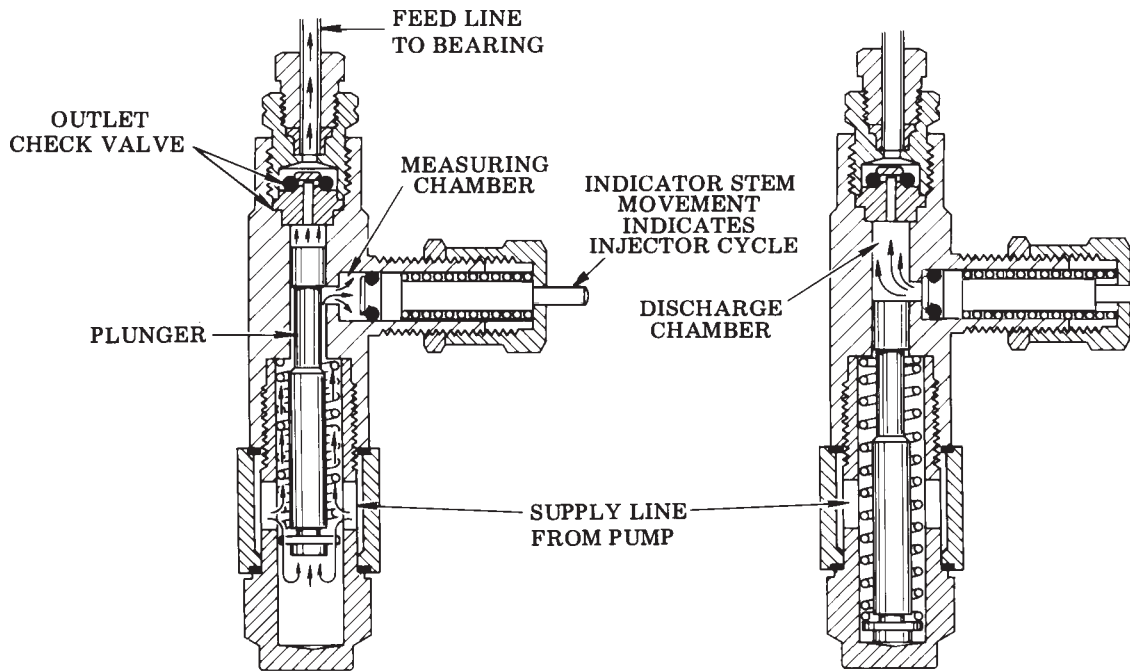

OPERATION

SUPPLY LINE UNDER PRESSURE

(Normal operating pressure 1500 psi)

Lubricant pressure moves plunger to force lubricant in the discharge chamber through the outlet check valve to the feed line.

Lubricant from supply line charges the measuring chamber.

SUPPLY LINE VENTED

(Vent pressure 200 psi maximum)

Plunger returns to normal position after supply line is vented, connecting measuring chamber to the discharge chamber. Flow from feed line is blocked by the outlet check valve.

Lubricant is automatically transferred from measuring chamber to discharge chamber.

INJECTOR ADJUSTMENT

Injector output is controlled by the position of the indicator cap which limits the travel of the packing retainer.

With the indicator cap hand tightened against its stop, the lubricant output is decreased to a minimum.

Retracting the indicator cap five full turns permits a maximum of .008 cu. in. to be dispensed. Use the graduations on the cap as an aid in setting the indicator.

When the injector has been adjusted for the proper lubricant output, the lock nut is tightened against the face of the indicator cap.

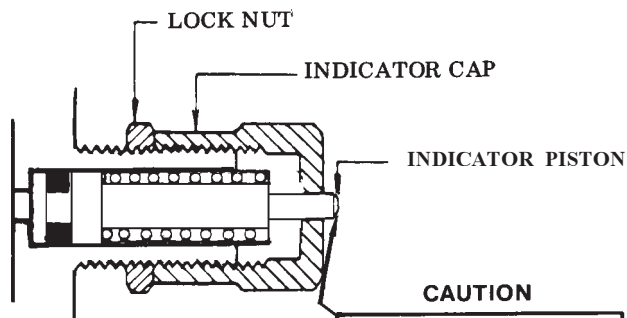

CAUTION

INDICATOR CAP MUST NOT EXTEND BEYOND RETRACTED POSITION OF INDICATOR STEM.

RETAIN THIS INFORMATION FOR FUTURE REFERENCE

When ordering replacement parts, list: Part Number, Description, Model Number and Series Letter. LINCOLN provides a Distributor Network that stocks equipment and replacement parts.