

LEVER GUN

16 OZ. CAPACITY

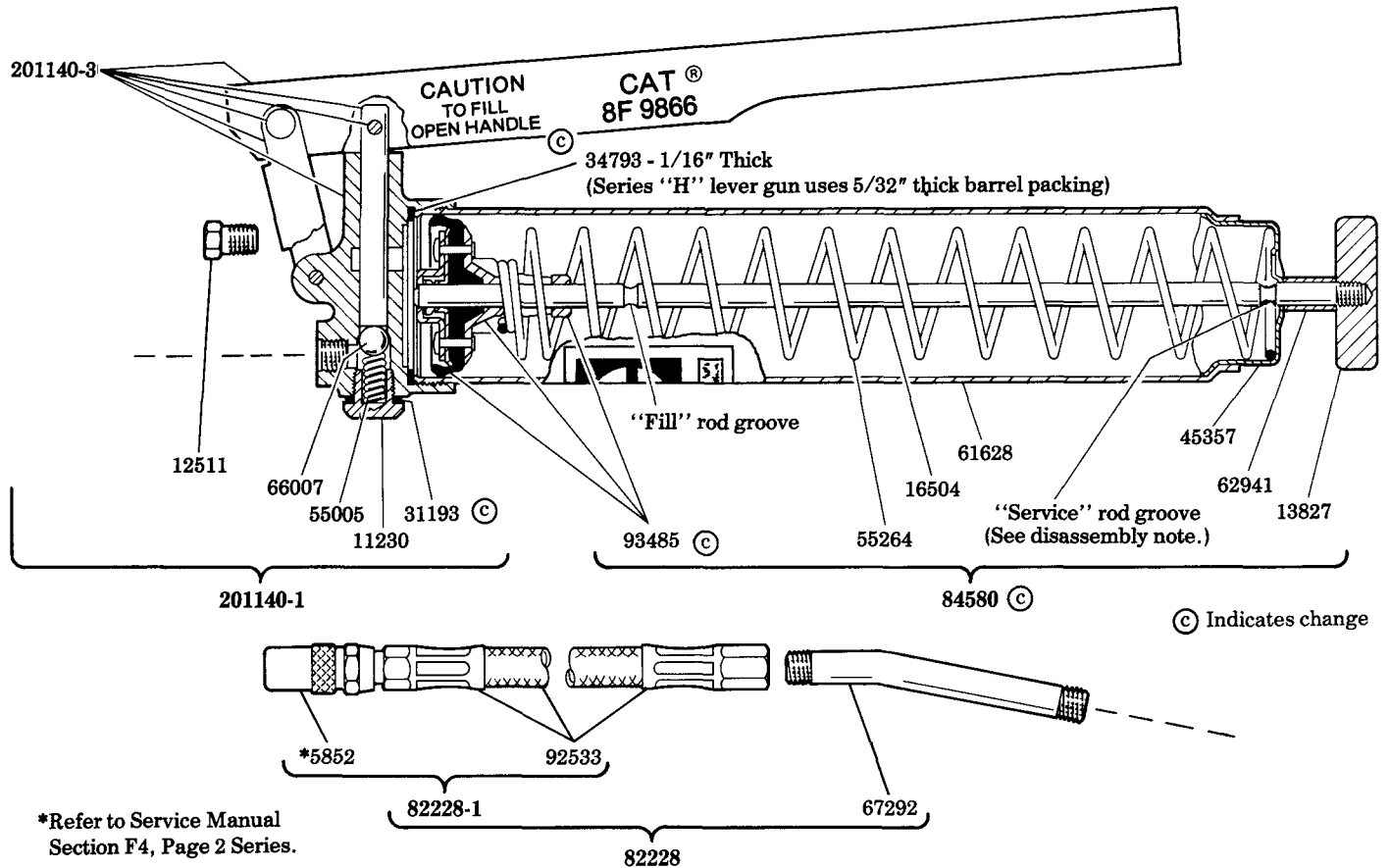

Models 201140
700236
Series "J"



OPERATING INSTRUCTIONS

Fill the lubricant container. Refer to reverse page for instructions.

Wipe fittings clean before lubricating. Push coupler onto fitting at slight angle and then center coupler on the fitting. Operate lever gun handle to lubricate, taking care not to damage seals by excessive pressure or lubricant volume. After lubricating, turn coupler at a slight angle to release grip of the coupler jaws.

CONTAINER DISASSEMBLY

When container assembly requires service, the 13827 Follower Handle must be removed by first slightly extending the 16504

Follower Rod and use pliers to grip follower rod between cap and 62941 Spacer, then loosen handle. DO NOT REMOVE HANDLE. Push forward on rod. Latch the "Service" rod groove into the 45357 Tube Cap. Remove handle.

CAUTION: Do not use the "Fill" rod groove for this purpose.

Push forward on rod end to expel follower, spring, cap and rod out of container tube. Place follower end securely against table top, firmly grasp cap and press down and to one side to unlatch rod from cap. Slowly raise cap to relieve spring force. After service, reassemble in reverse order.

SERVICE PARTS

PART	DESCRIPTION	PART	DESCRIPTION	PART	DESCRIPTION
5852	Hydraulic coupler	45357	Tube cap	82228	Nozzle extension
11230	Spring housing	55005	Spring	82228-1	Hose & coupler assembly
12511	Pipe plug	55264	Follower spring	84580	Container assembly
13827	Follower handle	61628	Container tube	92533	Hose
16504	Follower rod	62941	Spacer	93485	Follower
31193	Gasket	66007	Ball check	201140-1	Head assembly
34793	Barrel packing	67292	Pipe nipple	201140-3	Head & plunger

LINCOLN ST. LOUIS
4010 GOODFELLOW BLVD · ST. LOUIS, MO 63120 · (314) 383 5900



SECTION - D7
PAGE - 24J

TO INSTALL A LUBRICANT CARTRIDGE

- 1) Remove head and plunger assembly from container tube.
- 2) To remove an empty cartridge, pull back on the follower handle until the follower rod is fully extended. Then, carefully release the follower handle to eject the empty cartridge from the container tube. Pull back on the follower handle. When the follower rod is fully extended, pull it sideways to latch the rod groove into the keyhole slot in the container cap.

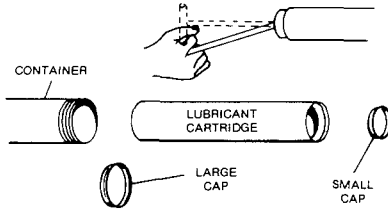

- 3) Remove the caps from both ends of the cartridge and insert the large open end of the cartridge into the container tube.
- 4) Loosely assemble the head and plunger assembly to the container tube. Extend the lever gun handle away from the container tube and disengage the follower rod from the container cap. Engage the follower rod with the follower by rotating the

follower handle. Exert force on the follower handle until lubricant oozes from the tube and head interface. Tighten container tube into the head and plunger assembly.

- 5) Disengage the follower rod from the follower by rotating the follower handle. Push the follower rod into the container.

TO EXPEL AIR POCKETS

- 1) Unscrew the container tube 1-1/2 turns from the head and plunger assembly.
- 2) Withdraw the follower rod from the container cap and engage it with the follower by rotating the follower handle. Exert force on the follower handle until lubricant oozes from the tube and head interface.
- 3) Tighten container tube into the head and plunger assembly. Disengage the follower rod from the follower by rotating the follower handle. Push the follower rod into the container.

IMPORTANT

Air pockets in the cartridge lubricant will cause the lever gun to lose its prime.

TO FILL LEVER GUN FROM BULK LUBRICANT CONTAINER

- 1) Remove head and plunger assembly from container tube.
- 2) Pack lubricant into cavity of the head and plunger assembly.
- 3) Insert the open end of the container tube into lubricant. Slowly pull the follower handle back while pushing the container tube deeper into the lubricant to prevent air pockets from being pulled into the container tube.
- 4) When the follower rod is fully extended, pull it sideways to latch the rod groove into the keyhole slot in the container cap.
- 5) Loosely assemble the head and plunger assembly to the filled container tube. Release the follower rod from the container cap and disengage the follower rod from the follower by rotating the follower handle. Push the follower rod into the container. Slowly unscrew the container tube from the head and plunger assembly until lubricant oozes from the interface. Tighten container tube into the head and plunger assembly.

- 2) Grasp follower between thumb and forefinger and flip the follower lip from the rear to the front side.

NOTE: The follower resembles a cup. When the lever gun is assembled for use with bulk lubricant, the cup opens toward the head assembly.

- 3) Reassemble follower into container tube, replace head assembly and tighten.



REAR SIDE

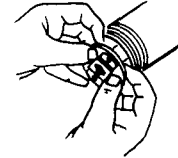

FRONT SIDE

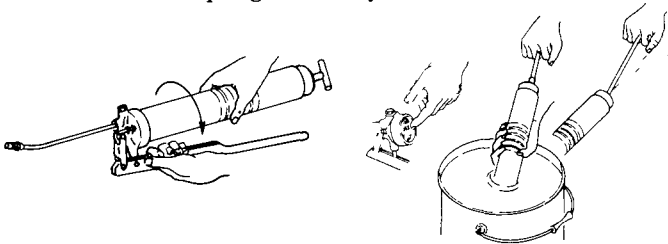

TO CONVERT LEVER GUN TO ALLOW FILLING FROM BULK CONTAINER OR FILLER PUMP

- 1) Unscrew the 201140-1 Head Assembly from the container tube. Push on the follower handle until the follower emerges from the other end of the container tube.

TO FILL LEVER GUN WITH A FILLER PUMP

Engage the follower rod with the follower by rotating the follower handle. Insert the lever gun filler nipple into the filler pump socket and extend the lever gun handle away from the container tube. Operate the filler pump to fill the lever gun container. When the follower rod groove is exposed, the container is filled (follower rod will be extended approximately 8 inches). Disengage the follower rod from the follower by rotating the follower handle. Push the follower rod into the container.

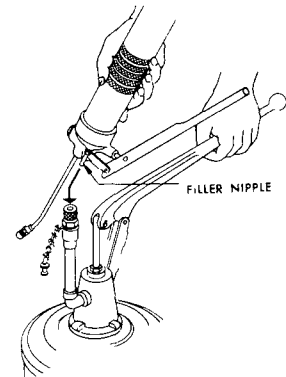

RETAIN THIS INFORMATION FOR FUTURE REFERENCE

When ordering replacement parts, list: Part Number, Description, Model Number, and Series Letter.

LINCOLN ST. LOUIS provides a Distributor Network that stocks equipment and replacement parts.

A list of Authorized Service Departments will be furnished upon request.