

**OWNER/OPERATOR MANUAL**

**SPECIFICATIONS**

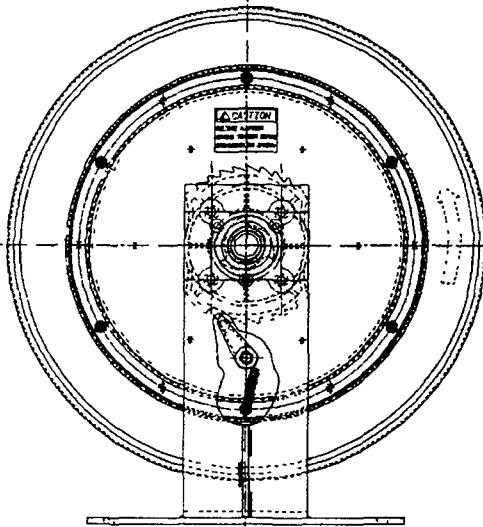

Maximum working pressure	8000 p.s.i.
Material Inlet	1/2" NPT (Female)
Material outlet	1/2" NPT (Female)
Sheave width	5-1/2"
Sheave diameter	19-1/4"
Drum diameter	12-3/4"
Overall width	8-1/4"
Overall height	21"
Overall depth	19-1/4"

Maximum hose capacities (Including hang down):

1/4" I.D. Grease hose (SAE 100 R2)	50 ft.
1/2" I.D. Oil hose (SAE 100 R3)	50 ft.

NOTE: Maximum hose capacities are based on SAE specified hoses. Exceeding these capacities voids warranty. Refer to DELIVERY HOSE INSTALLATION for proper hose to reel assembly.

**DESCRIPTION**

Model 82206-1 unit is a heavy duty lub-reel designed for bus and truck lubrication or wherever extra heavy duty construction and longer length delivery hose is required. The reel can be installed as a single unit or in multiple configurations.

Reel features include a reel latch that automatically locks at desired positions as the hose is extended and releases with a short pull on the hose.

**OWNER/OPERATOR RESPONSIBILITY**

It is the owner/operator responsibility to properly use and maintain this equipment.

The instructions and warnings contained in this manual shall be read and understood by the owner/operator prior to operating this equipment.

If an owner/operator does not under-

stand English, the contents of this manual shall be explained in the owner/operator native language to assure the owner/operator comprehends.

It is the owner/operator responsibility to maintain the legibility of all warning and instruction labels.

**The owner/operator shall retain this manual for future reference to important warnings, operating and maintenance instructions.**

## WARNING

**FAILURE TO HEED THE FOLLOWING WARNINGS INCLUDING MISUSE, OVER PRESSURIZING, MODIFYING PARTS, USING INCOMPATIBLE CHEMICALS AND FLUIDS, OR USING WORN OR DAMAGED PARTS, MAY RESULT IN EQUIPMENT DAMAGE AND/OR SERIOUS PERSONAL INJURY, FIRE, EXPLOSION, OR PROPERTY DAMAGE.**

- Do not exceed the stated maximum working pressure of the reel or of the lowest rated component in your system.
- Do not alter or modify any part of this equipment.
- Do not operate this equipment with *combustible gas*.
- Do not attempt to repair or disassemble the equipment while the system is pressurized.
- Make sure all fluid connections are securely tightened before using this equipment.
- Always read and follow the fluid manufacturer's recommendations regarding fluid compatibility, and the use of protective clothing and equipment.
- Check all equipment regularly and repair or replace worn or damaged parts immediately.
- Never point the dispensing valve at any part of the body or at another person.
- Never try to stop or deflect material from dispensing valve or leading connection or component with your hand or body.
- Always check equipment for proper operation before each use, making sure safety devices are in place and operating properly.
- Always follow the pressure relief procedure after shutting off the pump, when checking or servicing any part of the system, and when installing, cleaning or changing any part of the system.

### ASSEMBLY

Assemble reel as follows. Refer to SERVICE PARTS for part numbers and location.

- |   |   |   |
|---|---|---|
| <p>A. Assemble arbor and ratchet casting (237670) to support assembly (237656) with four hex head screws (50014) and four hex nuts (51022).</p> <p>B. Lubricate V-ring seal (237671) and place on arbor and ratchet casting (237670) with lip facing away from arbor ratchet.</p> <p>C. Assemble power spring assembly (237672) onto arbor and ratchet casting (237670) until spring canister bottoms on arbors shoulder.</p> <p>D. Lubricate V-ring seal (237673) and assemble onto arbor and ratchet casting (237670) with lip facing toward spring canister.</p> <p>E. Assemble axle (237675) to sheave assembly (237680) with three nuts (51010).</p> | <p>F. Assemble axle and sheave assembly to reel by sliding axle (237675) through bearings in the arbor and ratchet casting (237670). Secure with washer (48217) and TRU-ARC (68424). Shim as required using shims (48385) between washer (48217) and arbor and ratchet casting (237670) to eliminate axle end play.</p> <p>G. Rotate sheave assembly (237680) and align six mounting holes with mating holes in power spring canister (237672). Secure with five carriage bolts (237738), carriage bolt (237739) and six nuts (51010).</p> <p>NOTE: The carriage bolt (237739) is assembled in hole adjacent to pawl pin.</p> <p>H. Assemble swivel assembly (237684) in axle (237675) and tighten.</p> | <p>I. Assemble inlet adapter (237686) into swivel assembly (237684) and secure with U-keeper (15674).</p> <p>J. Lubricate U-cup packing (237679) and assemble into axle (237675) with lip down.</p> <p>K. Assemble outlet adapter (237678) into axle (237675). Secure with U-keeper (15674).</p> <p>L. Assemble hose clamp (237760) to sheave assembly (237680) with carriage bolt (237738). Secure with nut (51010).</p> <p>M. Assemble latch pawl (237683) to pawl pin on power spring assembly (237672) and secure with washer (48327) and TRU-ARC (66316).</p> <p>N. Assemble extension spring (237695) to latch pawl (237683) and carriage bolt (237739). Secure with locknut (51304).</p> |
|---|---|---|

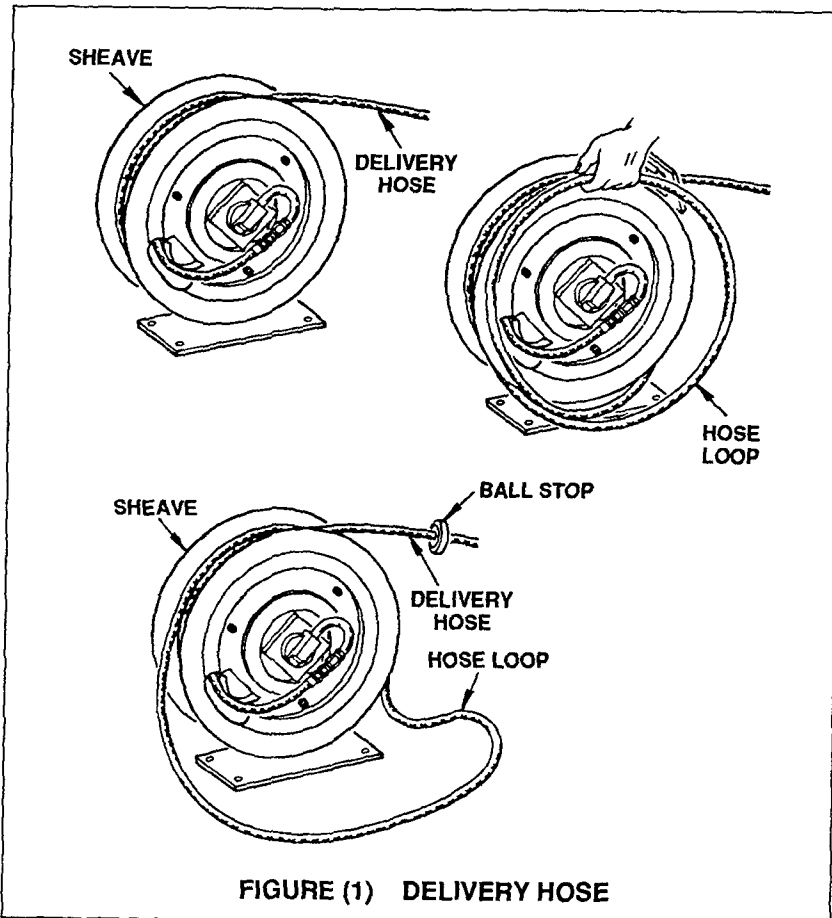

FIGURE (1) DELIVERY HOSE

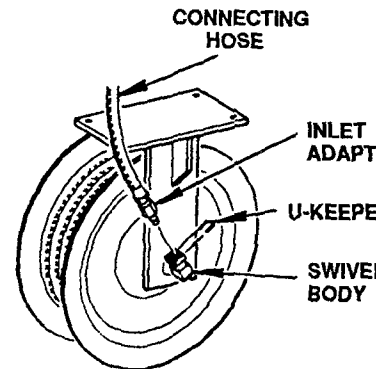

FIGURE (2) CONNECTING HOSE

## INSTALLATION

### DELIVERY HOSE INSTALLATION (MAXIMUM SPRING TENSION)

For smoother operation during retraction and to increase hose life, "detail" hose by wiping entire hose length with a light lubricating oil before installing on reel.

Assemble outlet adapter to hose and tighten securely. Use teflon tape on threads to prevent leaks.

See Figure (1). Insert hose end with outlet adapter and secure to axle head with U-keeper. Make sure seal is installed correctly in axle before assembling.

### **CAUTION**

To prevent damaging hose connections and/or components when pulling hose from reel, pull on the hose itself and not on the control valve or swivel. Do not pull or jerk on the hose when fully withdrawn from the reel.

From open side of reel, loop entire length of hose onto reel in a clockwise direction. Pull hose out to wind power spring. When hose is completely extended, latch reel to prevent it from unwinding.

Continue to add loops of hose and pull out hose until power spring winds tight.

### IMPORTANT INSTRUCTIONS

Perform the following instructions as stated to correctly set the power spring for maximum tension.

Allow reel to retract two full revolutions and latch reel. Carefully unloop remaining hose from reel.

### **CAUTION**

To avoid damaging reel components, always make sure hose clamp is properly installed.

Position hose clamp so that approximately 1/2 loop of hose remains on reel and latching does not occur when hose is fully extended.

While holding hose, allow reel to retract hose until desired height from floor is obtained, then latch reel.

Slide ball stop over free end of hose and tighten screws to secure ball stop on hose.

Power spring is now set to maximum tension.

### ADJUSTING SPRING TENSION

### **CAUTION**

To prevent premature power spring failure, spring tension should be adjusted so that it requires at least two full turns of the reel sheave before the spring is wound tight.

Should less spring tension be desired, pull hose out to provide slack and latch reel.

Unwind one loop of hose from reel. Pull excess hose out and unlatch reel to retract hose.

Check tension and repeat above procedure until desired tension is obtained.

#### ATTACHING CONNECTING HOSES

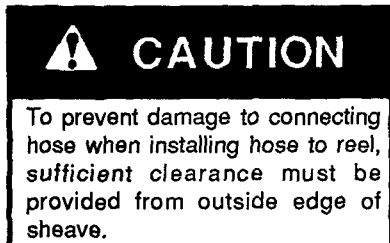

See Figure (2). Remove U-keeper and inlet adapter from swivel body.

Assemble swivel adapter to connecting hose.

Reconnect inlet adapter to swivel body and replace U-keeper.

Connect other end of connecting hose to material supply line source or connection.

#### SAFETY INFORMATION

Read and understand all warnings, cautions and instructions before operating this equipment. Extreme caution

should be used when operating this equipment as *personal injury and/or property damage* can result from equipment misuse. Adequate personal protection is recommended to prevent splashing of material on the skin or in the eyes. **ALWAYS** disconnect air coupler from pump when the pump is not being used.

#### PRESSURE RELIEF PROCEDURE

Always perform this procedure when the pump is shut off and before checking, servicing, installing, cleaning or repairing any part of this system.

Perform the following procedure:

- A. Disconnect the air supply to the pump.
- B. Point the dispensing valve away from yourself and others.
- C. Open the dispensing valve into an appropriate container until the pressure is relieved.

If the above procedure does not relieve the pressure, the dispensing valve or hose may be restricted. To relieve the pressure, very slowly loosen the hose end coupling. Then loosen completely and clear the dispensing valve and/or hose.

#### DISASSEMBLY

To disassemble, perform ASSEMBLY procedures in reverse.

#### REPAIR

Repair is limited to replacement of listed service parts. Special procedures and tools are required. Contact Lincoln Customer Service, One Lincoln Way, St. Louis, MO 63120-1578, (314) 679-4300 for your nearest authorized service center.

When ordering replacement parts, list: part number, description, model number and series letter.

#### INSPECTION

Prior to operation or maintenance a visual inspection shall be made. Check reel system for leaks, worn or missing parts.

Any reel that appears to be damaged in any way, is badly worn or operates abnormally shall be removed from use until repairs are made. Contact factory authorized service center for repairs.

If overpressurizing of the equipment is believed to have occurred, contact a factory authorized service center for inspection of the reel.

Annual inspection by a factory authorized service center is recommended.

#### LIMITED WARRANTY

Lincoln, A Pentair Company, warrants that lubrication equipment, materials dispensing equipment and other related equipment manufactured by it will be free from defects in material and workmanship during the one (1) year following the date of purchase. If equipment proves to be defective during this warranty period, it will be repaired or replaced without charge, provided that factory examination indicates the equipment to be defective. To obtain repair or replacement, it must be shipped, transportation charges prepaid, with proof of date of purchase to a Lincoln authorized Warranty and Service Center, within the one (1) year following the date of purchase.

This warranty is extended to the original retail purchaser only. This warranty does not apply to equipment damaged from accident, overload, abuse, misuse, negligence, faulty installation or abrasive or corrosive materials, or to equipment repaired or altered by anyone not authorized by Lincoln to repair or alter the equipment. This warranty applies only to equipment installed and operated according to the recommendations of Lincoln or its authorized field personnel. No other express warranty applies to lubrication equipment, materials dispensing equipment, and other related equipment manufactured by Lincoln.

ANY IMPLIED WARRANTIES applicable to lubrication equipment, materials dispensing equipment, and other related equipment manufactured by Lincoln INCLUDING THE WARRANTIES OF MERCHANTABILITY AND FITNESS FOR A PARTICULAR PURPOSE, WILL LAST ONLY FOR ONE (1) YEAR FROM THE DATE OF PURCHASE. SOME STATES DO NOT ALLOW LIMITATIONS ON HOW LONG AN IMPLIED WARRANTY LASTS, SO THE ABOVE LIMITATION MAY NOT APPLY TO YOU.

In no event shall Lincoln be liable for incidental or consequential damages. The liability of Lincoln on any claim for loss or damage arising out of the sale, resale, or use of lubrication equipment, materials dispensing equipment, and other related equipment shall in no event exceed the purchase price. SOME STATES DO NOT ALLOW THE EXCLUSION OR LIMITATION OF INCIDENTAL OR CONSEQUENTIAL DAMAGES, SO THE ABOVE LIMITATION OR EXCLUSION MAY NOT APPLY TO YOU.

THIS WARRANTY GIVES YOU SPECIFIC LEGAL RIGHTS AND YOU MAY ALSO HAVE OTHER RIGHTS WHICH VARY FROM STATE TO STATE.

**SERVICE PARTS**

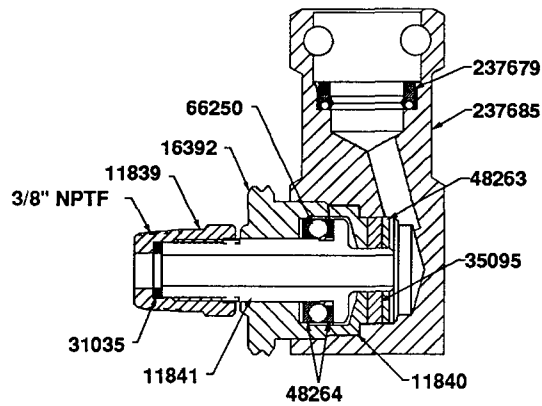
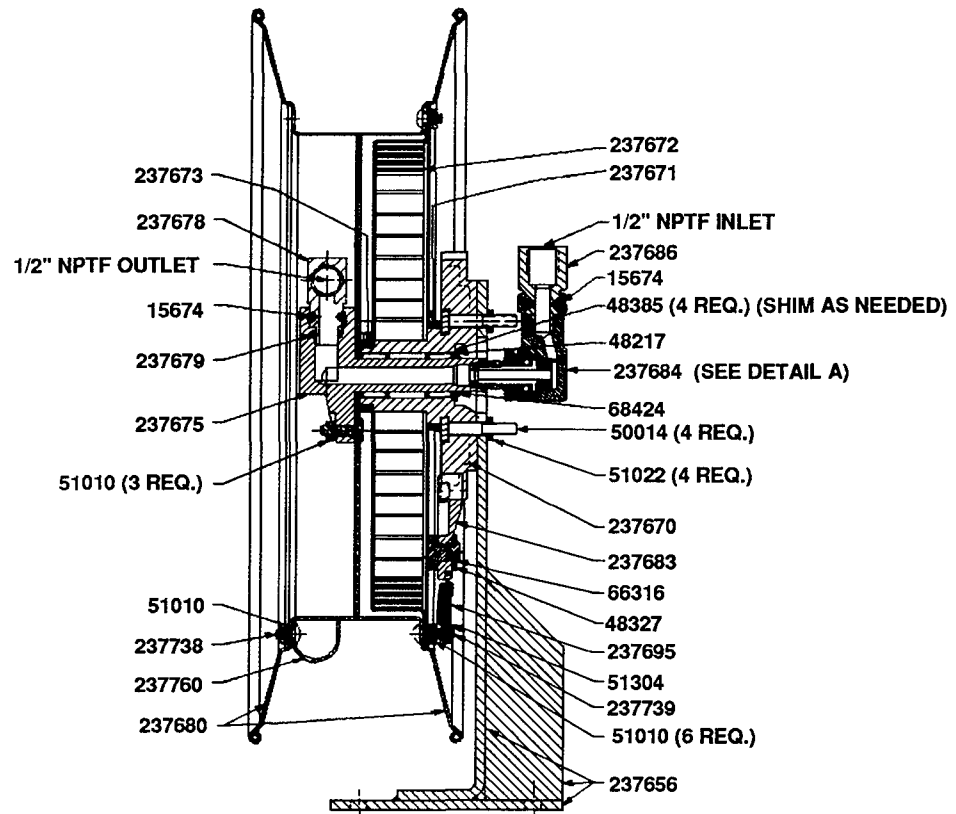

**DETAIL A**

**237684 SWIVEL ASSEMBLY**

## SERVICE PARTS (CONT)

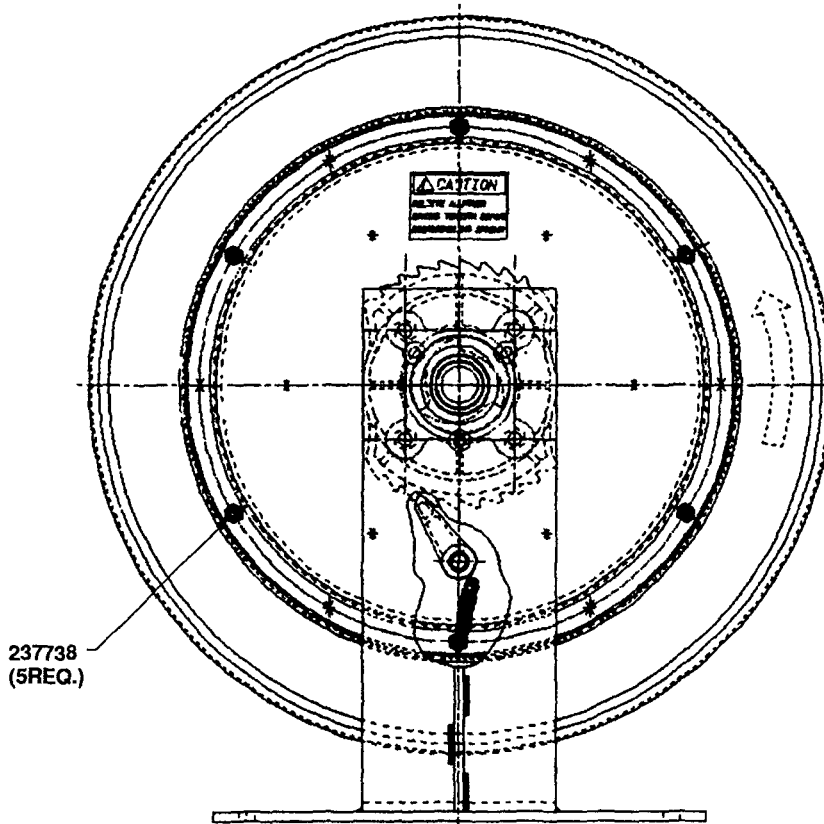

PART	QTY	DESCRIPTION	PART	QTY	DESCRIPTION
15674	2	U-keeper	237656	1	Support assembly
11839	1	Swivel adapter	237670	1	Arbor and ratchet casting
11840	1	Packing retainer	237671	1	V-ring seal
11841	1	Swivel stud	237672	1	Power spring assembly
16392	1	Swivel nut	237673	1	V-ring seal
31035	1	Gasket	237675	1	Axle
35095	1	Swivel packing	237678	1	Outlet adapter
48217	1	Washer	237679	2	U-cup packing
48263	1	Packing washer	237680	1	Sheave assembly
48264	2	Thrust washer	237683	1	Latch pawl
48327	1	Washer	237684	1	Swivel assembly
48385	4	Shim washer	237685	1	Swivel body
50014	4	Hex head screw	237686	1	Inlet adapter
51010	10	Hex nut	237695	1	Extension spring
51022	4	Hex nut	237738	6	Carriage bolt
51304	1	Locknut	237739	1	Carriage bolt
66250	13	Ball	237760	1	Hose clamp
66316	1	Tru-arc			
68424	1	Tru-arc			