

BARE REEL
HEAVY DUTY
REGULAR HOSE CAPACITY

Models 82838
82838-1, 82894
Series "G"

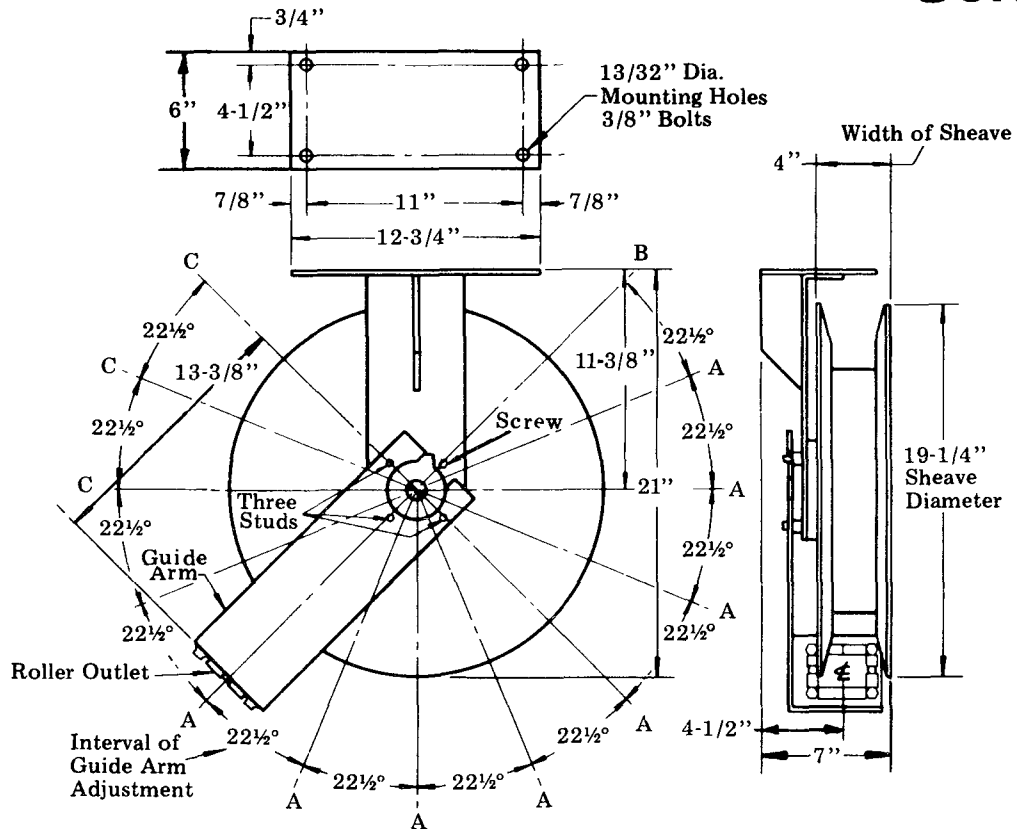

FIG. 1
HOSE REEL
DIMENSIONS

INSTALLATION

The guide arm may be positioned in 22½° increments as shown above. For ease of operation and increased hose life, the guide arm should be positioned to minimize hose flexure as the delivery hose passes thru the roller outlet.

Three studs must be used to securely attach the guide arm. In some cases it may be necessary to change the position of the hex head screw and one stud in order to position the guide arm.

The hose clamp must be relocated if the guide arm is in position "B" or "C" in the illustration above. Refer to Bare Reel dwg for hose clamp locations.

DIAGRAMATIC VIEWS

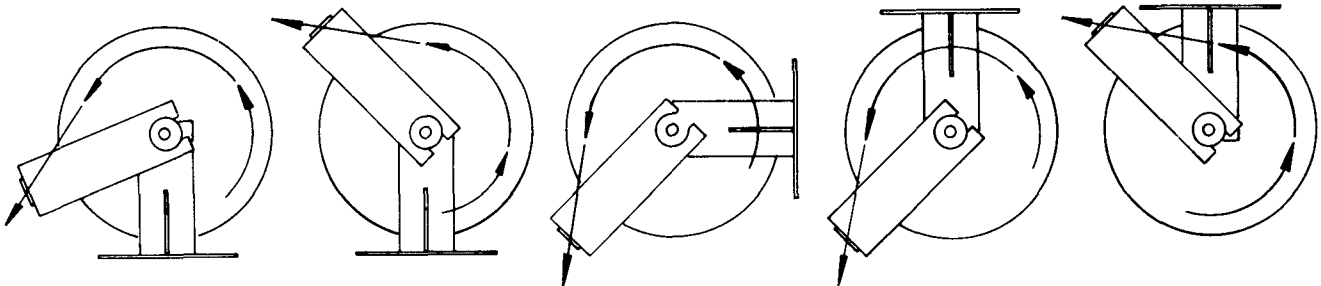

FIG. 2
LUBROVAN
INSTALLATION
CONTRACTOR TYPE

FIG. 3
FLOOR
INSTALLATION

FIG. 4
WALL, POST
OR ABOVE BENCH
INSTALLATION

FIG. 5
CEILING
INSTALLATION
OR FOR USE
WITH LUBREEL
SUPPORT STAND

FIG. 6
UNDER BENCH
INSTALLATION

NOTE: Arrow indicates direction of hose as it is withdrawn from hose reel.



One Lincoln Way St. Louis, Missouri 63120-1578
 (314) 679-4200 Telex 44881

SECTION - E35
PAGE - 20M

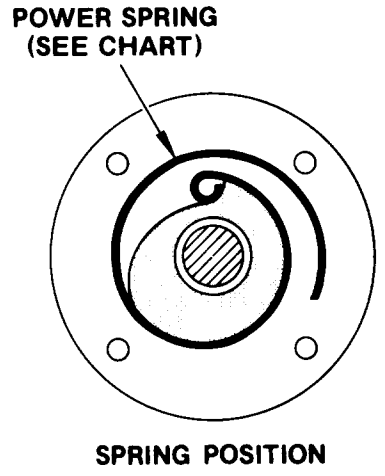
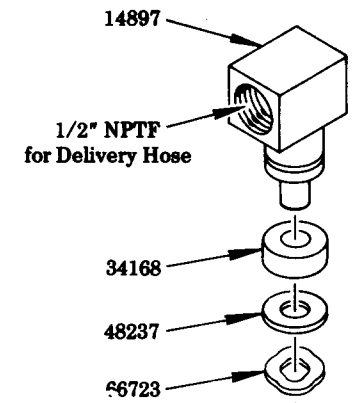
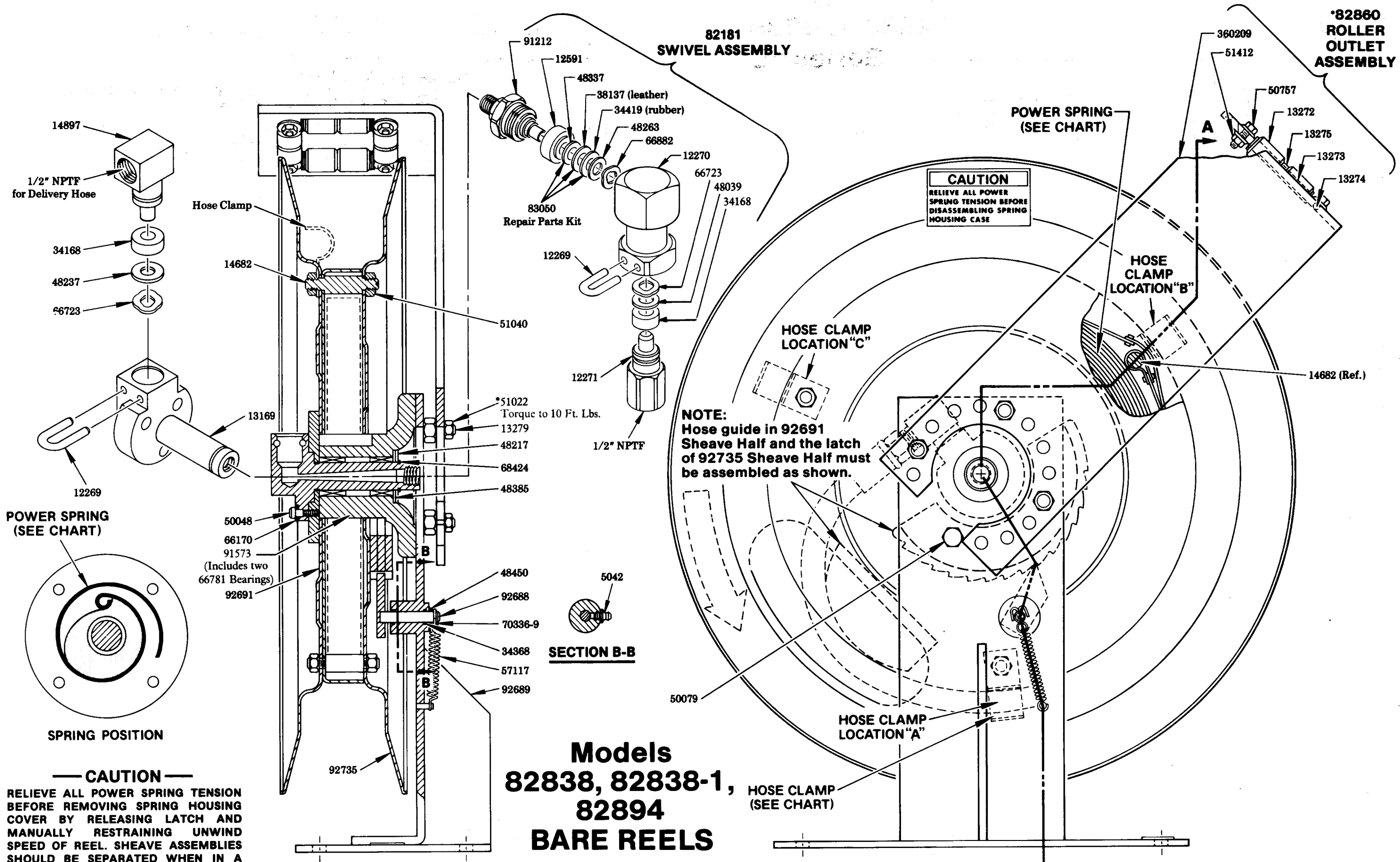

CAUTION
RELIEVE ALL POWER SPRING TENSION BEFORE REMOVING SPRING HOUSING COVER BY RELEASING LATCH AND MANUALLY RESTRAINING UNWIND SPEED OF REEL. SHEAVE ASSEMBLIES SHOULD BE SEPARATED WHEN IN A HORIZONTAL POSITION WITH 92691 DOWN ON A FLAT SURFACE.

NOTE:
The power spring is restrained by a steel retainer band. For added safety, the power spring should be wired securely to the retainer band in at least three places before removal from the spring housing.

NOTES:
1) Apply pipe compound on 82181 Swivel threads before installing swivel to hose reel.
*2) Indicates parts not included with Model 82838-1 Bare Reel.

NOTE:
Hose guide in 92691 Sheave Half and the latch of 92735 Sheave Half must be assembled as shown.

CAUTION
RELIEVE ALL POWER SPRING TENSION BEFORE DISASSEMBLING SPRING HOUSING CASE

MODEL	HOSE CLAMP	POWER SPRING
82838	45816, 45817	57083
82838-1	—	57083
82894	45817	57089

**Models
82838, 82838-1,
82894
BARE REELS**

**ADAPTERS FOR DELIVERY AND CONNECTING HOSES
NOT FURNISHED WITH BARE REEL - MUST BE ORDERED SEPARATELY**

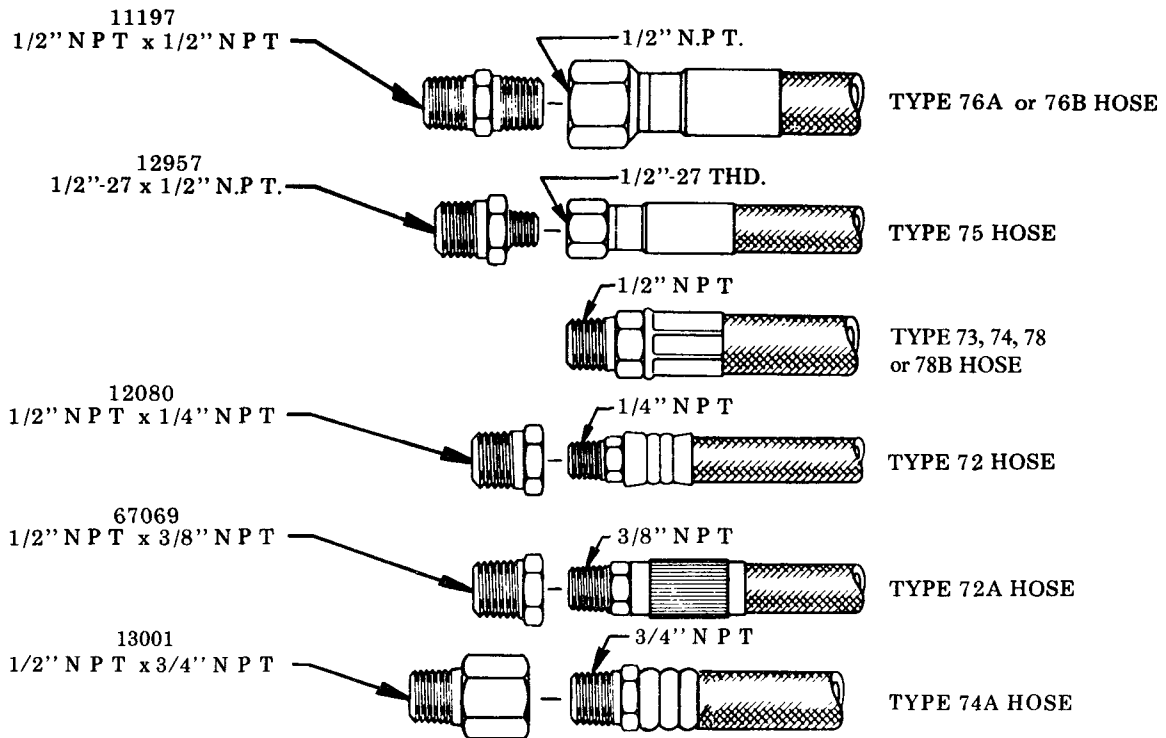

SERVICE PARTS

PART	QUAN.	DESCRIPTION	PART	QUAN.	DESCRIPTION
5042	1	Straight fitting	48450	1	Washer
12269	2	Keeper	50048	3	Screw
12270	1	Swivel body	50079	1	Screw
12271	1	Adapter	50757	4	Bolt
12591	1	Retainer	51022	3	Nut
13169	1	Shaft	51040	6	Nut
13272	8	Roller	51412	4	Nut
13273	2	Pin	57117	1	Spring
13274	2	Pin	66170	3	Washer
13275	2	Spacer	66723	2	Spring washer
13279	3	Stud	66781	2	Bearing
14682	3	Stud	66882	1	Spring washer
14897	1	Adapter	68424	1	Retaining ring
34168	2	Packing	70336-9	1	Cotter pin
34368	2	O-ring	82181	1	Swivel ass'y
34419	1	Packing (rubber)	82860	1	Roller outlet ass'y
38137	1	Packing (leather)	91212	1	Swivel stud ass'y
48039	1	Washer	91573	1	Arbor ass'y
48217	1	Washer	92688	1	Pawl ass'y
48237	1	Washer	92689	1	Support ass'y
48263	1	Washer	92691	1	Sheave ass'y
48337	1	Washer	92735	1	Sheave ass'y
48385	4	Shim washer	360209	1	Roller support arm

RETAIN THIS INFORMATION FOR FUTURE REFERENCE

When ordering replacement parts, list: Part Number, Description, Model Number, and Series Letter

LINCOLN provides a Distributor Network that stocks equipment and replacement parts

A list of Authorized Service Departments will be furnished upon request