

Model 84698 BARE REEL

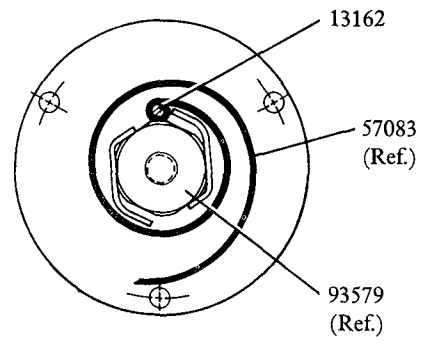

SPRING POSITION

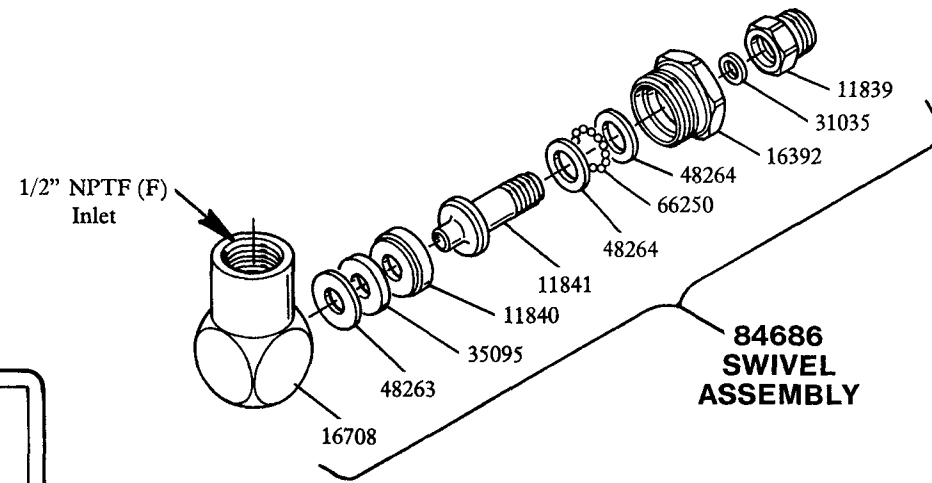

**84686
SWIVEL
ASSEMBLY**

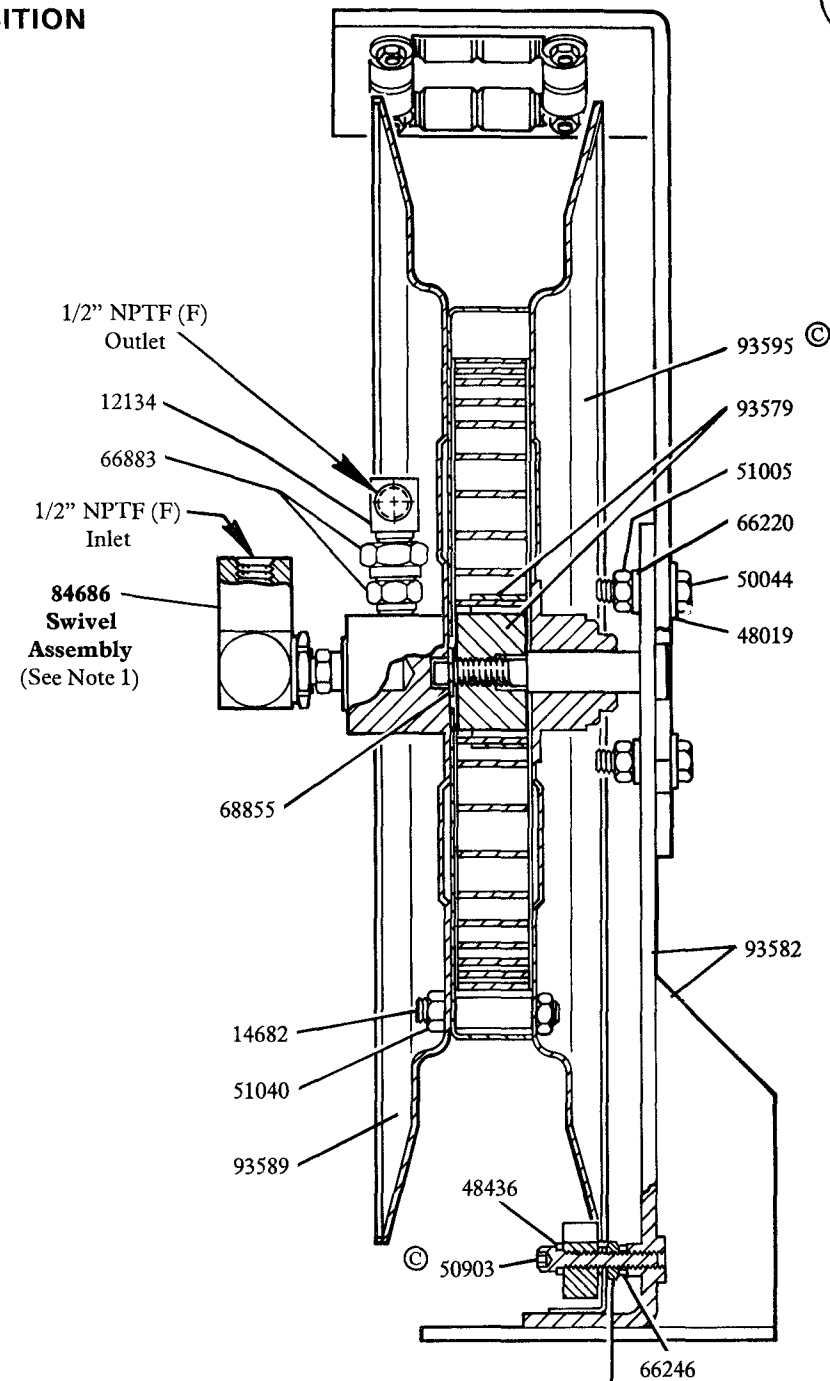

SECTION A-A

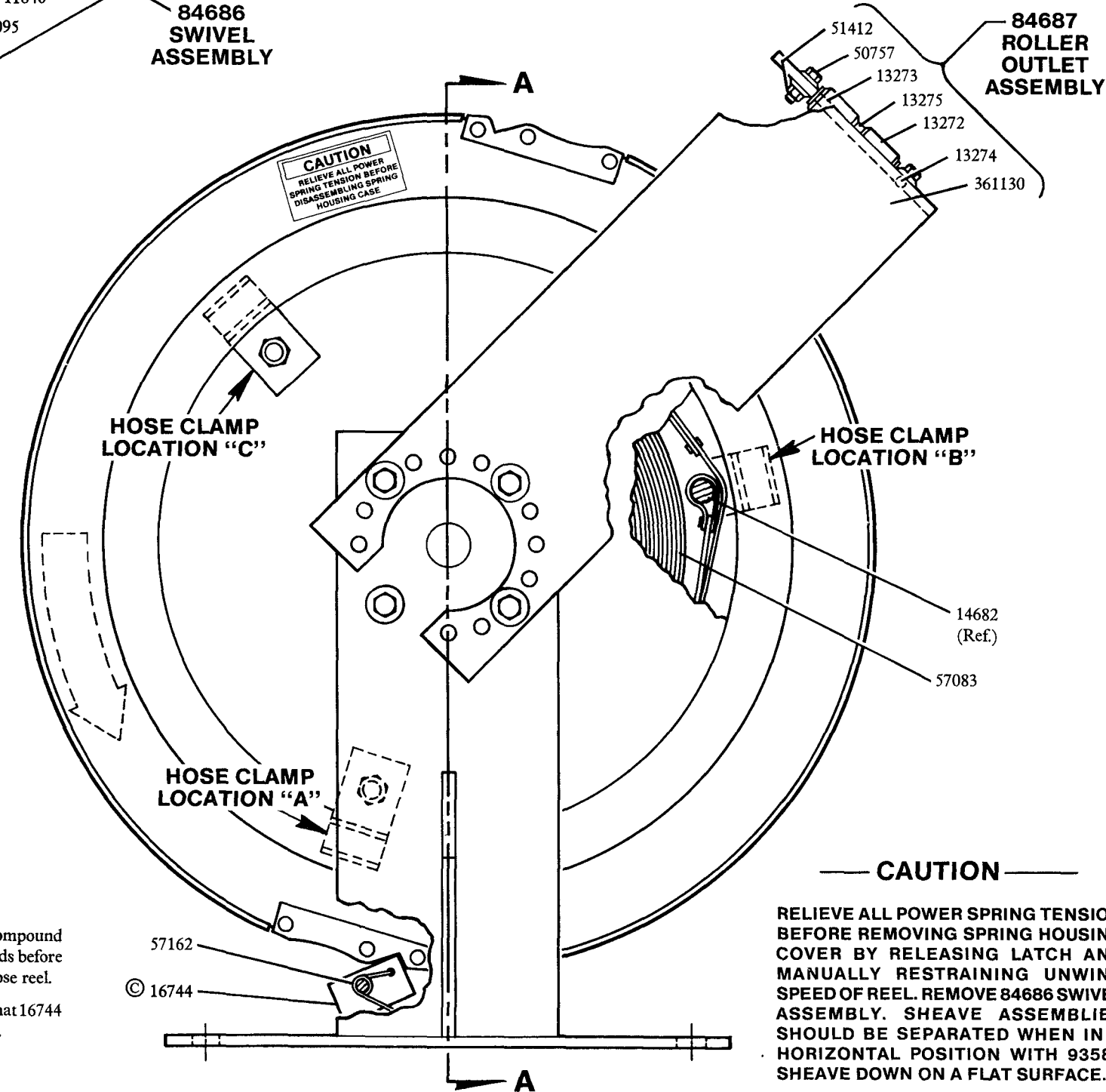

**84687
ROLLER
OUTLET
ASSEMBLY**

HOSE CLAMP LOCATION "C"

HOSE CLAMP LOCATION "B"

HOSE CLAMP LOCATION "A"

CAUTION

RELIEVE ALL POWER SPRING TENSION BEFORE REMOVING SPRING HOUSING COVER BY RELEASING LATCH AND MANUALLY RESTRAINING UNWIND SPEED OF REEL. REMOVE 84686 SWIVEL ASSEMBLY. SHEAVE ASSEMBLIES SHOULD BE SEPARATED WHEN IN A HORIZONTAL POSITION WITH 93589 SHEAVE DOWN ON A FLAT SURFACE.

NOTE:

The power spring is restrained by a steel retainer band. For added safety, the power spring should be wired securely to the retainer band in at least three places before removal from the spring housing.

NOTES:

- 1) Apply Loctite pipe compound to 84686 Swivel threads before installing swivel to hose reel.
- 2) Adjust 51022 Nut so that 16744 Latch is free to move.

© Indicates Change

HOSE CLAMP	HOSE TYPE
45816	73, 74 & 76B
45817	72, 72A & 75

**ADAPTERS FOR DELIVERY AND CONNECTING HOSES
NOT FURNISHED WITH BARE REEL - MUST BE ORDERED SEPARATELY**

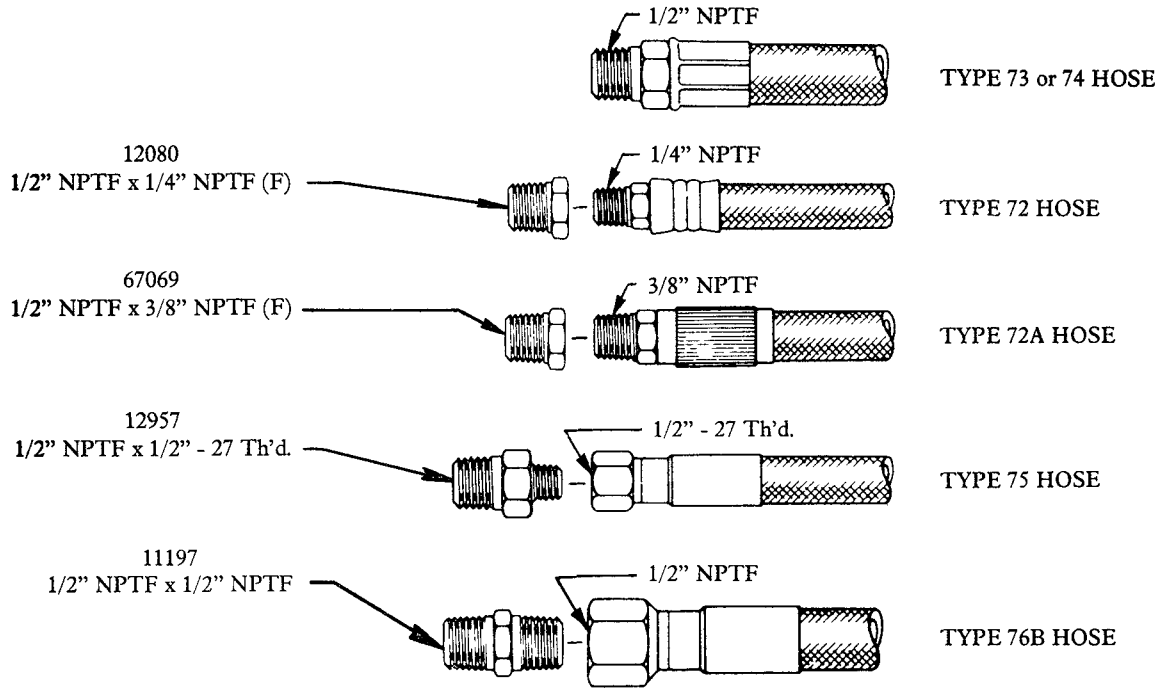

Cabinet and Mounting Rails:
Refer to Service Manual,
Section E35, Page 38 Series.

SERVICE PARTS

PART	QUAN.	DESCRIPTION	PART	QUAN.	DESCRIPTION
11839	1	Swivel adapter	50757	4	Bolt
11840	1	Packing retainer	50903	1	Screw
11841	1	Swivel stud	51005	4	Nut
12134	1	Elbow	51022	1	Jam nut
13162	1	Spring pin	51040	6	Locknut
13272	8	Roller	51412	4	Nut
13273	2	Pin	57083	1	Power spring
13274	2	Pin	57162	1	Latch spring
13275	2	Spacer	66220	4	Lockwasher
14682	3	Stud	66246	1	Lockwasher
16392	1	Swivel nut	66250	13	Ball
16708	1	Swivel body	66883	1	Adapter union
16744	1	Latch pawl	68855	1	Retaining ring
31035	1	Gasket	84686	1	Swivel assembly
35095	1	Swivel packing	84687	1	Roller outlet assembly
48019	4	Washer	93579	1	Arbor
48263	1	Packing washer	93582	1	Support
48264	2	Thrust washer	93589	1	Sheave half
48436	1	Washer	93595	1	Sheave half
50044	4	Screw	361130	1	Roller support arm

RETAIN THIS INFORMATION FOR FUTURE REFERENCE

When ordering replacement parts, list: Part Number, Description, Model Number, and Series Letter.

LINCOLN provides a Distributor Network that stocks equipment and replacement parts.

A list of Authorized Service Departments will be furnished upon request.