

BARE REEL

Models 84695, 84695-1 84697, 84697-1

MAX. WORKING PRESSURE - 1000 PSI

Series "B"

**FIG. 1
HOSE REEL
DIMENSIONS**

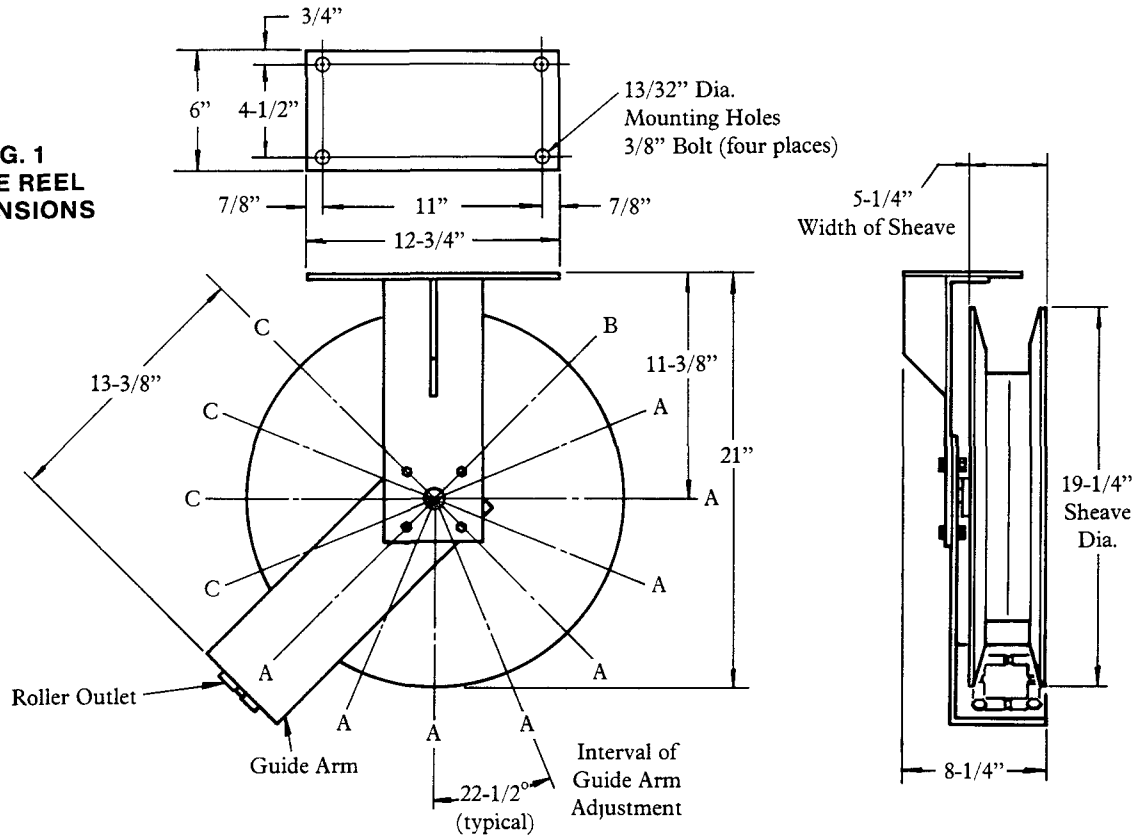

INSTALLATION

The guide arm may be positioned in $22\text{-}1/2^\circ$ increments as shown above. For ease of operation and increased hose life, the guide arm should be positioned to minimize hose flexure as the delivery hose passes through the roller outlet.

Three hex head screws must be used to securely attach the guide arm. The hose clamp must be relocated if the guide arm is in position "B" or "C" in the illustration above. Refer to bare reel drawing for hose clamp locations.

DIAGRAMATIC VIEWS

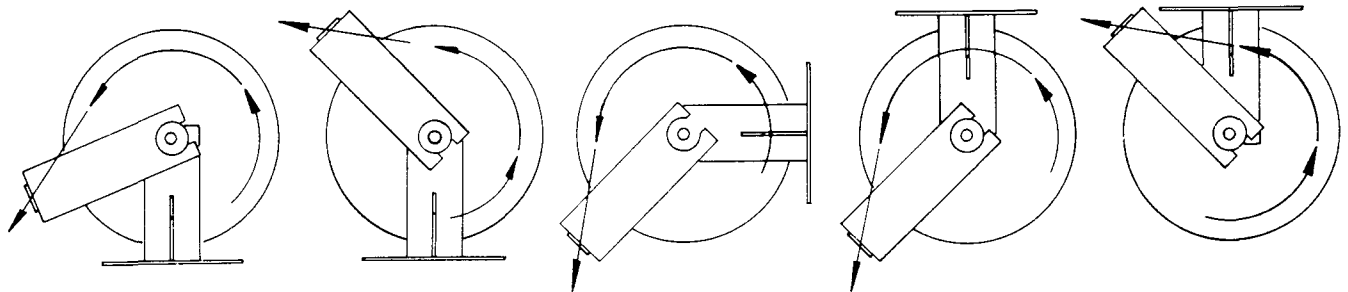

**FIG. 2
ABOVE BENCH
INSTALLATION**

**FIG. 3
FLOOR
INSTALLATION**

**FIG. 4
WALL, POST
OR ABOVE BENCH
INSTALLATION**

**FIG. 5
CEILING
INSTALLATION**

**FIG. 6
UNDER BENCH
INSTALLATION**

NOTE: Arrow indicates direction of hose as it is withdrawn from hose reel.

LINCOLN

One Lincoln Way St. Louis, Missouri 63120-1578
(314) 679-4200 Telex 44881

SECTION - **E35**
PAGE - **51B**

— WARNING —

When installing supply line to hose reel, sufficient clearance **MUST** be provided from outside edge of 46018 Sheave to prevent damage to connecting hose.

**Models
84695, 84695-1
84697, 84697-1
BARE REELS**

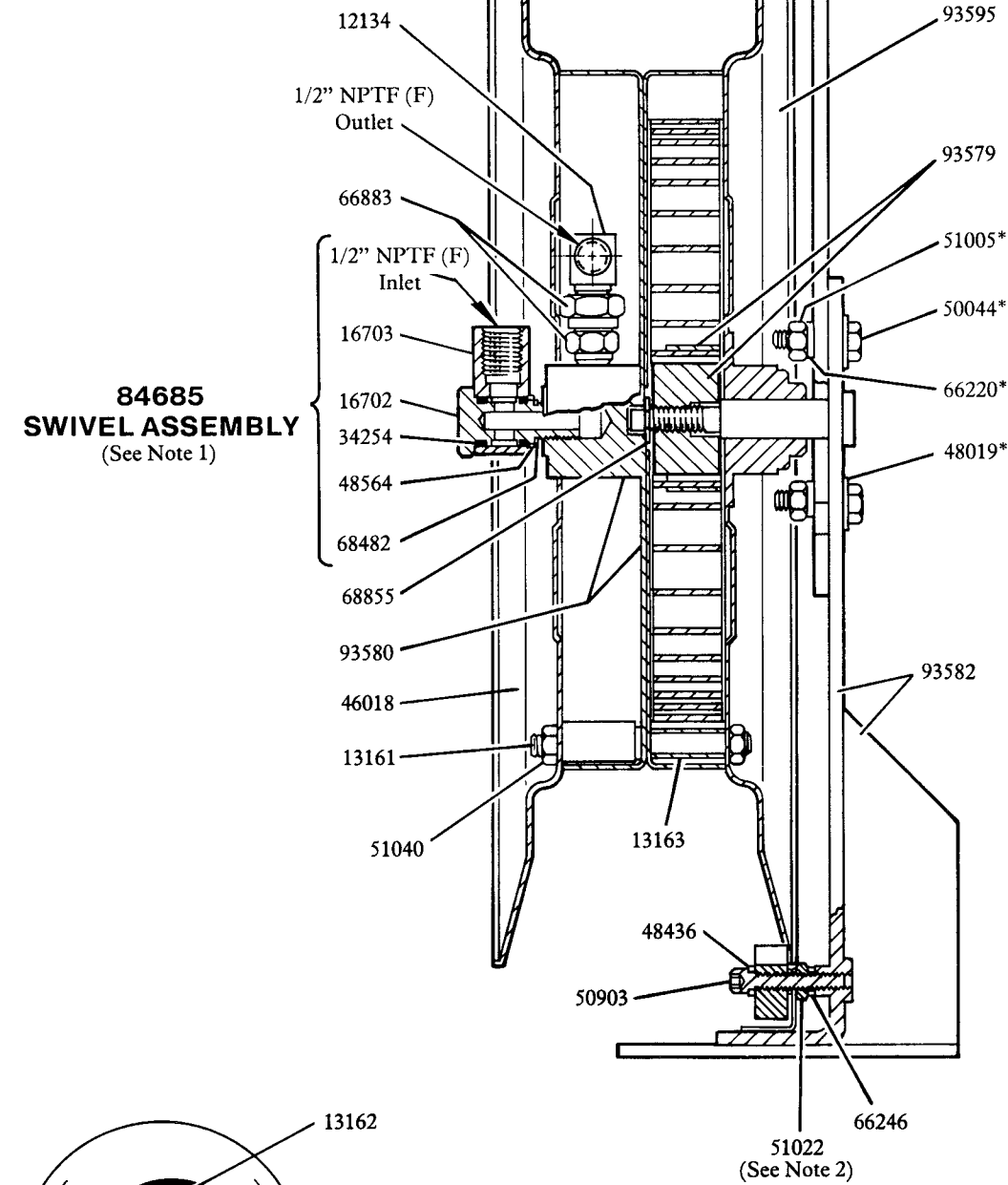

**84685
SWIVEL ASSEMBLY**
(See Note 1)

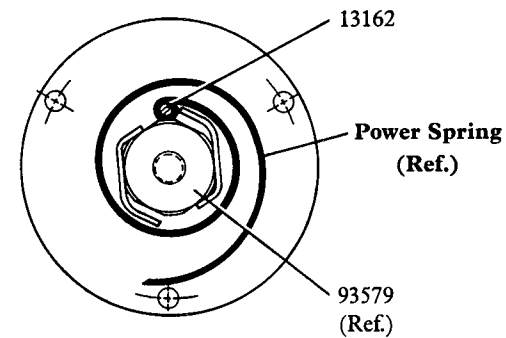

SPRING POSITION

SECTION A-A

MODEL	POWER SPRING	MAX. HOSE CAPACITY
84695	57083	40' of Type 73 Hose
84695-1	57083	40' of Type 73 Hose
84697	57082	50' of Type 73 Hose
84697-1	57082	50' of Type 73 Hose

NOTES:

- 1) Apply Loctite pipe compound to 84685 Swivel threads before installing swivel to hose reel.
- 2) Adjust 51022 Nut so that 16744 Latch is free to move.
- *3) Indicates parts not included with Models 84695-1 and 84697-1 Bare Reels.

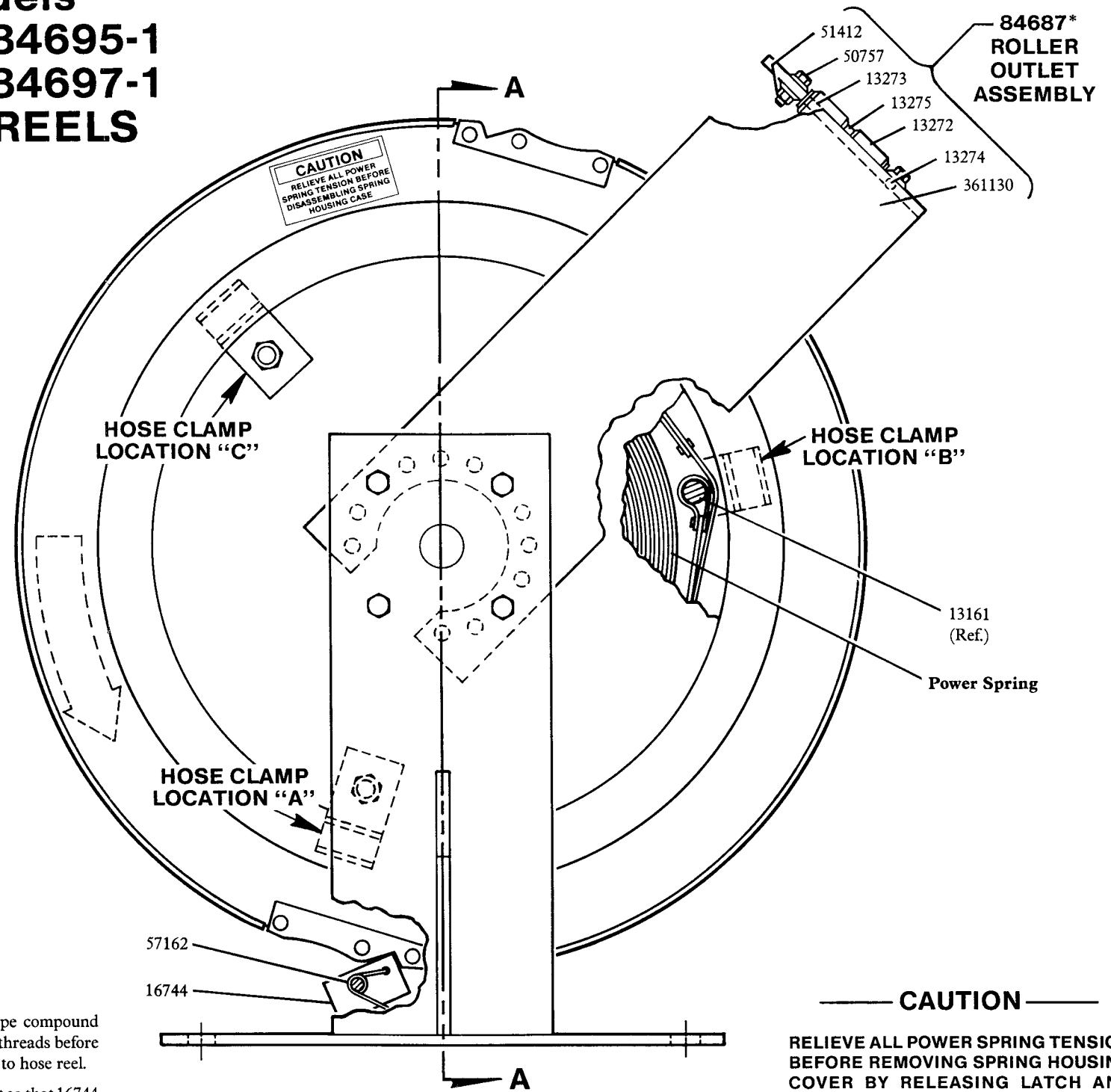

— CAUTION —

RELIEVE ALL POWER SPRING TENSION BEFORE REMOVING SPRING HOUSING COVER BY RELEASING LATCH AND MANUALLY RESTRAINING UNWIND SPEED OF REEL. REMOVE 84685 SWIVEL ASSEMBLY. SHEAVE ASSEMBLIES SHOULD BE SEPARATED WHEN IN A HORIZONTAL POSITION WITH 46018 SHEAVE DOWN ON A FLAT SURFACE.

NOTE:

The power spring is restrained by a steel retainer band. For added safety, the power spring should be wired securely to the retainer band in at least three places before removal from the spring housing.

	MODEL 84695	MODEL 84697
*HOSE CLAMP	HOSE TYPE	HOSE TYPE
45816	73 & 74	73 & 74
45817	72 & 72A	72 & 72A
45818	—	74A & 78

**ADAPTERS FOR DELIVERY AND CONNECTING HOSES
NOT FURNISHED WITH BARE REEL - MUST BE ORDERED SEPARATELY**

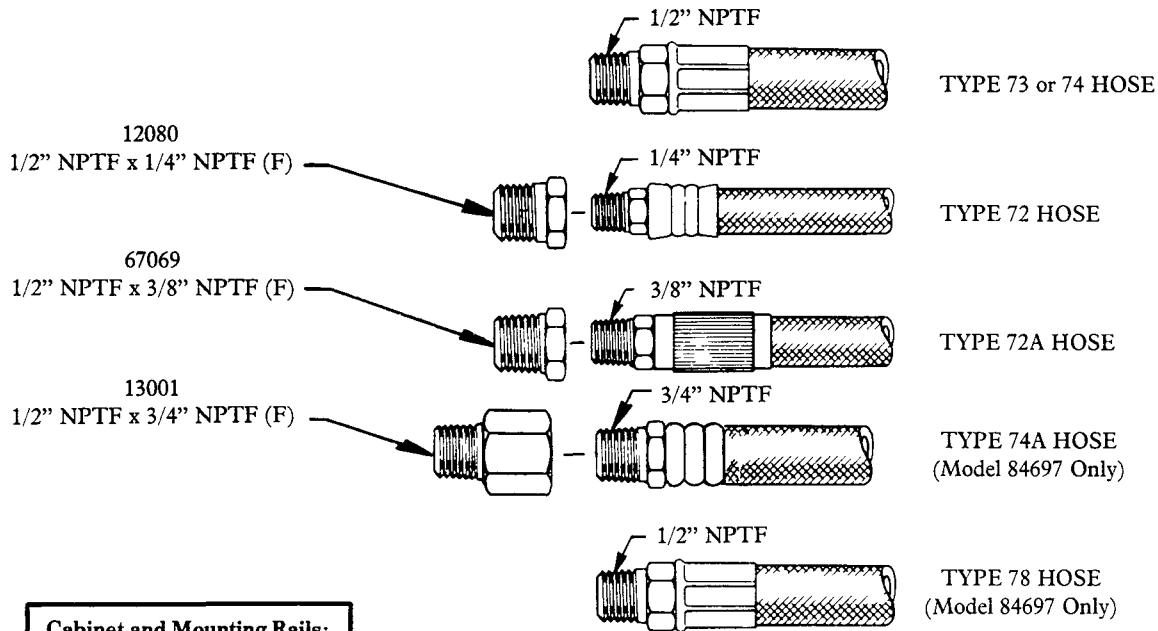

Cabinet and Mounting Rails:
Refer to Service Manual,
Section E35, Page 38 Series.

SERVICE PARTS

PART	QUAN.	DESCRIPTION	PART	QUAN.	DESCRIPTION
12134	1	Elbow	50903	1	Screw
13161	3	Stud	51005	4	Nut
13162	1	Spring pin	51022	1	Jam nut
13163	3	Spacer	51040	6	Locknut
13272	8	Roller	51412	4	Nut
13273	2	Pin	57162	1	Latch spring
13274	2	Pin	66220	4	Lockwasher
13275	2	Spacer	66246	1	Lockwasher
16702	1	Inlet stud	66883	1	Adapter union
16703	1	Swivel block	68482	1	Retaining ring
16744	1	Latch	68855	1	Retaining ring
34254	2	O-ring	84685	1	Swivel assembly
46018	1	Sheave half	84687	1	Roller outlet assembly
48019	4	Washer	93579	1	Arbor
48436	1	Washer	93580	1	Spring housing
48564	1	Washer	93582	1	Support
50044	4	Screw	93595	1	Sheave half
50757	4	Bolt	361130	1	Roller support arm

RETAIN THIS INFORMATION FOR FUTURE REFERENCE

When ordering replacement parts, list: Part Number, Description, Model Number, and Series Letter.

LINCOLN provides a Distributor Network that stocks equipment and replacement parts.

A list of Authorized Service Departments will be furnished upon request.