

FLOW GUN

MAX. OPERATING PRESSURE - 5000 PSI
TESTED WITH GREASE. PURGE BEFORE USING.

Models 83586
83587
Series "B"

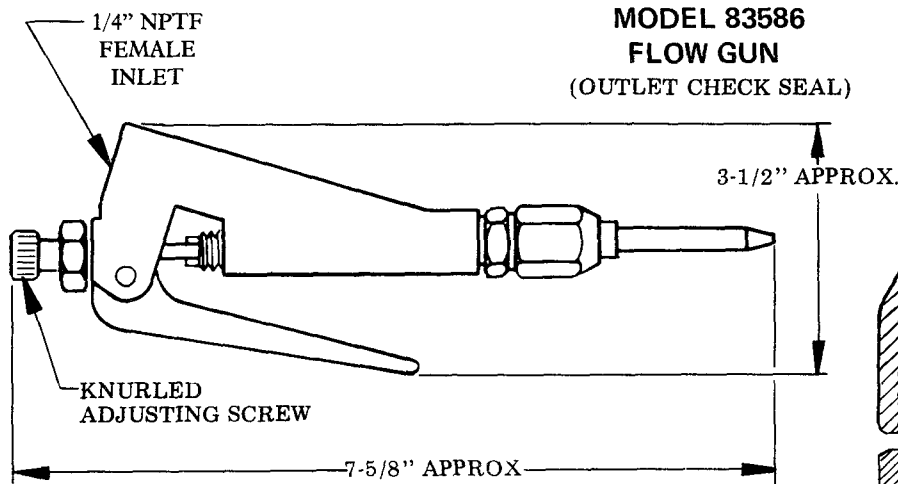

OPERATION AND SERVICE

The knurled adjusting screw permits increase or decrease of spring pressure for closing the valve. This adjustment also controls handle travel and the amount of opening between needle and seat. Valve opening can further be adjusted by removing the knurled adjusting screw and spring and then adjusting the spring guide and set screw. Leakage of material from flow gun tip may result from weak spring pressure or foreign particles lodged between needle and seat. Remove 92124 Seat and 92246 Needle Assembly and clean. Replace parts if worn or damaged. If material leaks from 14457 Packing Retainer, replace the 34430-18 U-Cup Packing. To use Teflon Packing Kit 83990, remove 34430-18 U-Cup and 14457 Packing Retainer and replace with 38146 Packing and 14699 Packing Retainer.

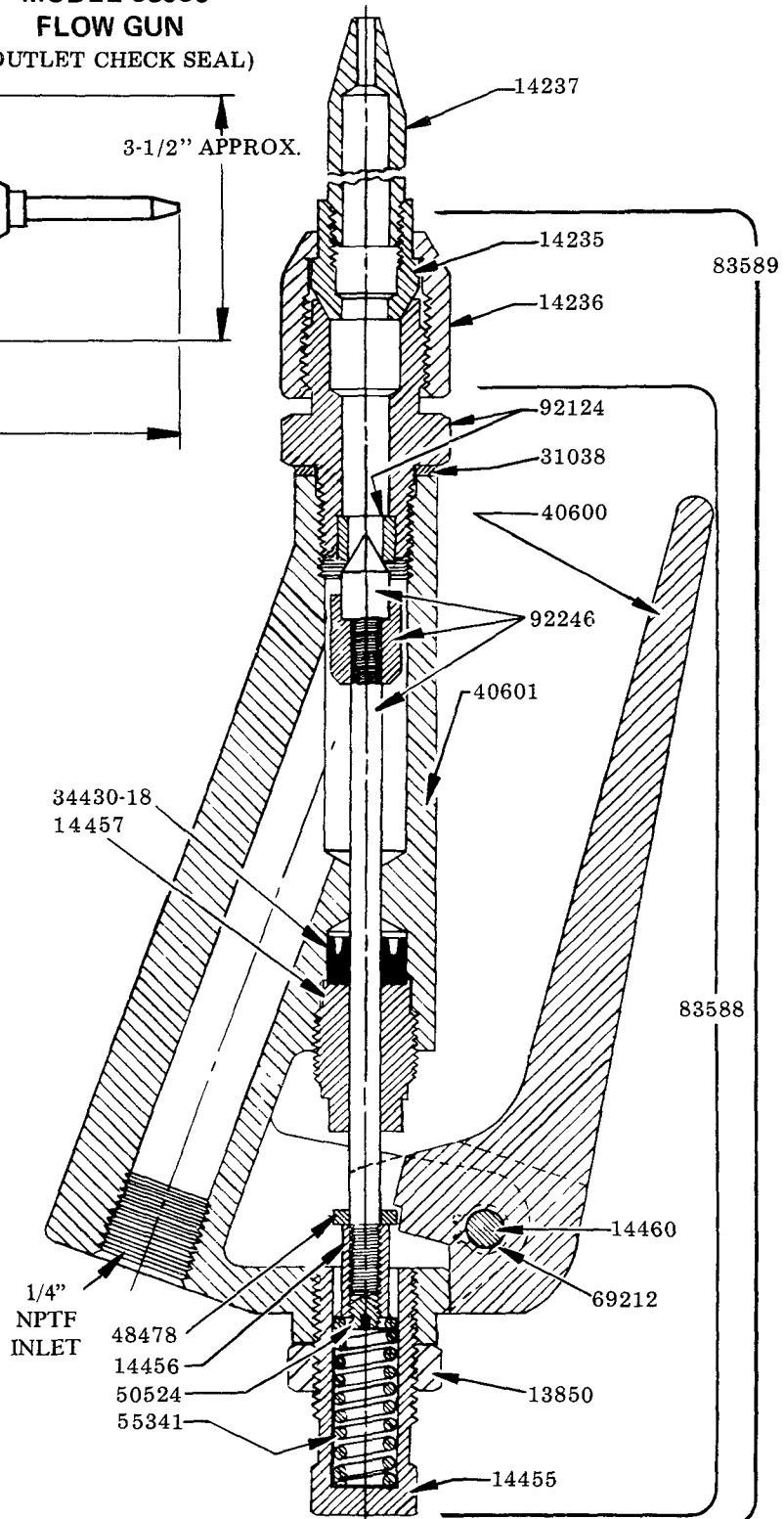
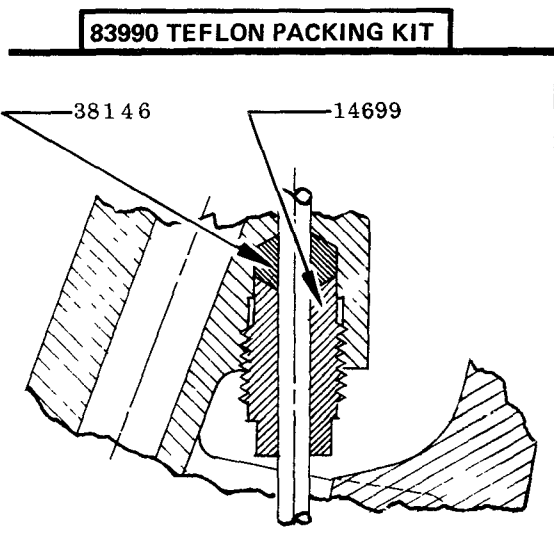

A DIVISION OF
LINCOLN McNEIL
CORPORATION
One Lincoln Way St. Louis MO 63120 (314) 679-4200

SECTION - F21
PAGE - 15E

MODEL 83587
(TIP SEAL)

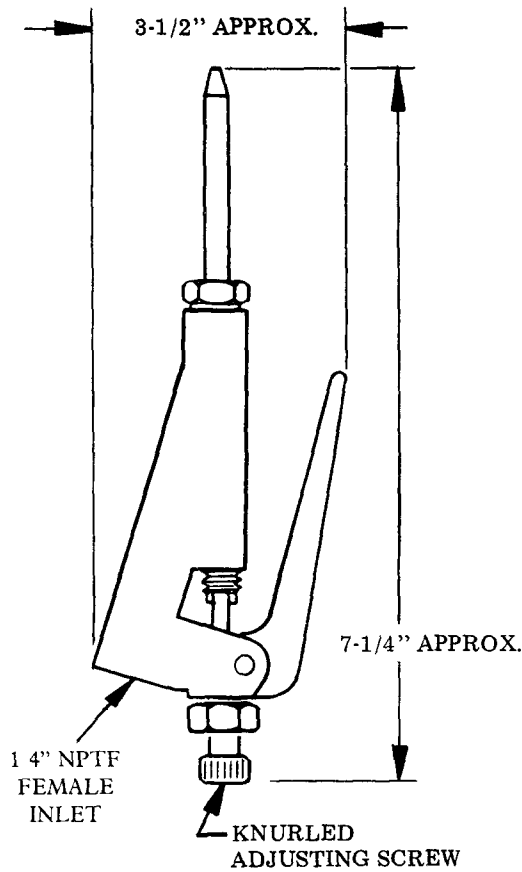

OPERATION AND SERVICE

Same as for Model 83586 except for difference in needle and seat. If foreign particles become lodged between needle and seat, remove 93372 Tip & Rod Assembly and clean, replace if worn or damaged.

SERVICE PARTS

PART	DESCRIPTION
13850	Jam nut
14235	Needle cap
14236	Sleeve
14237	Nozzle
14455	Spring retainer
14456	Spring guide
14457	Packing retainer
14460	Pin
31038	Gasket
34430-18	U-cup packing
40600	Handle
40601	Body
48478	Washer
50524	Set screw
55341	Spring
69212	Retaining ring
83588	Flow gun assembly
83589	Flow gun & seat assembly
92124	Seat assembly
92246	Needle assembly
93372	Tip & rod assembly

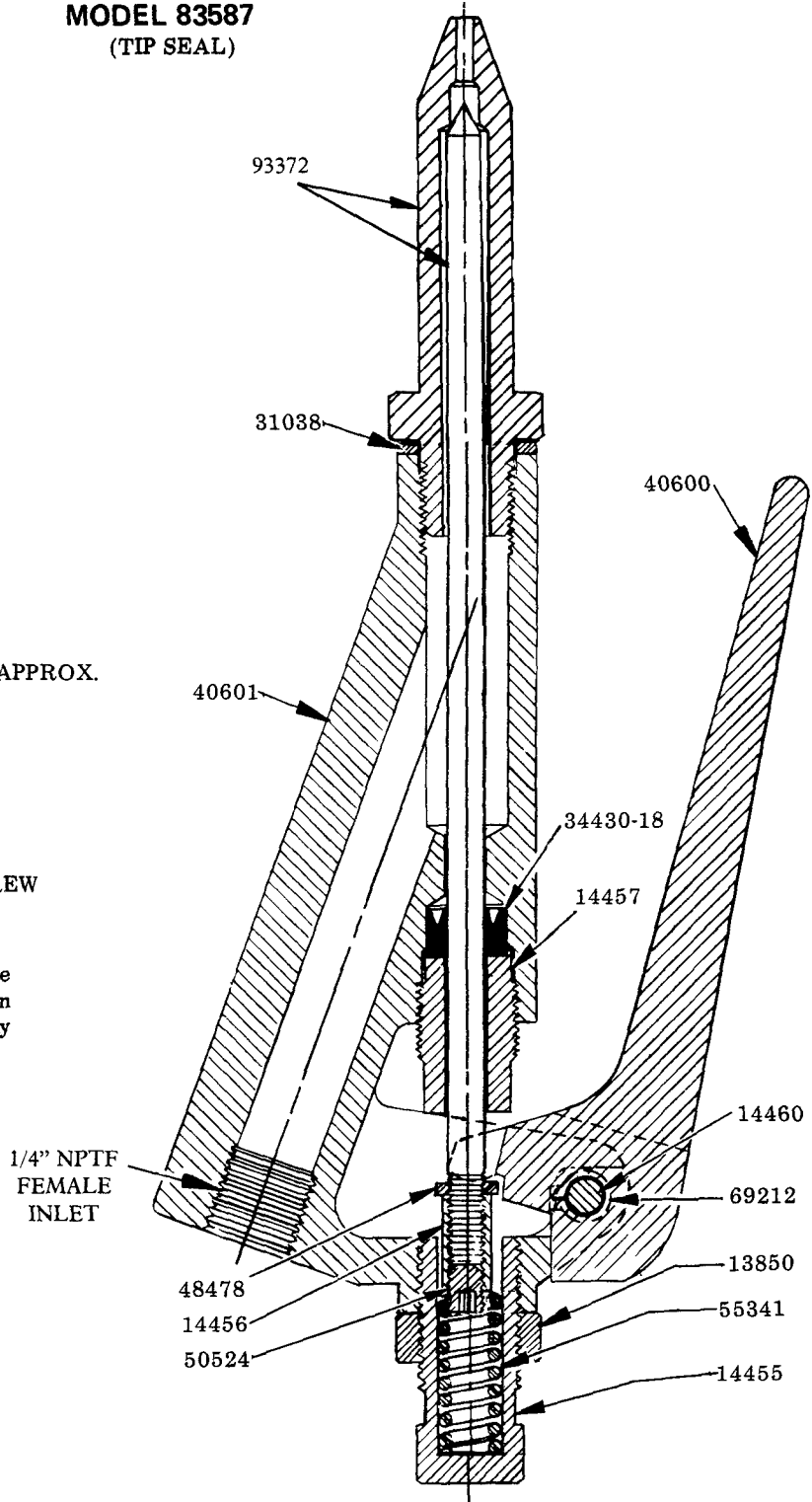

RETAIN THIS INFORMATION FOR FUTURE REFERENCE

When ordering replacement parts, list: Part Number, Description, Model Number, and Series Letter.

LINCOLN provides a Distributor Network that stocks equipment and replacement parts.
A list of Authorized Service Departments will be furnished upon request.