

CAUTION

Before meter can be placed in service "After Repair", meter must be tested and approved in accordance with U.S. Government's Weights and Measures Standards.

CAUTION

New metering systems must be purged prior to installation of metering control valve to free system of contaminates.

OPERATION

The Meter can handle petroleum products such as automatic transmission fluid, S.A.E. 5 to 50 Wt. motor oil, S.A.E. 80 to 240 wt. gear oil and antifreeze fluid (ethylene glycol). The preset meter is set by turning the knob counterclockwise to the desired amount of material to be dispensed. The trigger is then depressed and locked in the "on" position. The pointer knob rotates clockwise towards zero where it strikes a pin in the meter face above the "0" zero, which releases the lock bar automatically stopping the flow.

The meter can be stopped prior to dispensing the preset amount by rotating the pointer manually clockwise until it strikes the pin above the "0" zero, or by pushing the pin counterclockwise by hand thus leaving the knob indicating the remaining amount to be dispensed.

SPECIFICATIONS:

Dial Capacity	1 to 60 Liters
Totalizer	Liters
Flow Max.	4 Gallons per min. (15 liters per min.)
Flow Min.	0.4 Gallons per min. (1.5 Liters per min.)
Operating Pressure Max.	1000 PSI (70 Bar)
Operating Temp. Max.	110°F (45° C)
Accuracy	+/- 0.65%
Weight	3.3 Lbs. (1.5 Kg.)
Meter Inlet & Outlet Thds.	1/2 NPTF

Americas:
One Lincoln Way
St. Louis, MO 63120-1578
USA
Phone +1.314.679.4200
Fax +1.800.424.5359

Europe/Africa:
Heinrich-Hertz-Str 2-8
D-69183 Walldorf
Germany
Phone +49.6227.33.0
Fax +49.6227.33.259

Asia/Pacific:
25 Int'l Business Park
#01-65 German Centre
Singapore 609916
Phone +65.562.7960
Fax +65.562.9967

© Copyright 2001
Printed in USA

Web site:
www.lincolnindustrial.com



CAUTION

If meter is mishandled, the Lock Bar (Item 16) can become and Screw may fail to contact Pock Pawl (Item 17). If this happens, the meter will not shut off at preset amount. Frequent inspection is recommended.

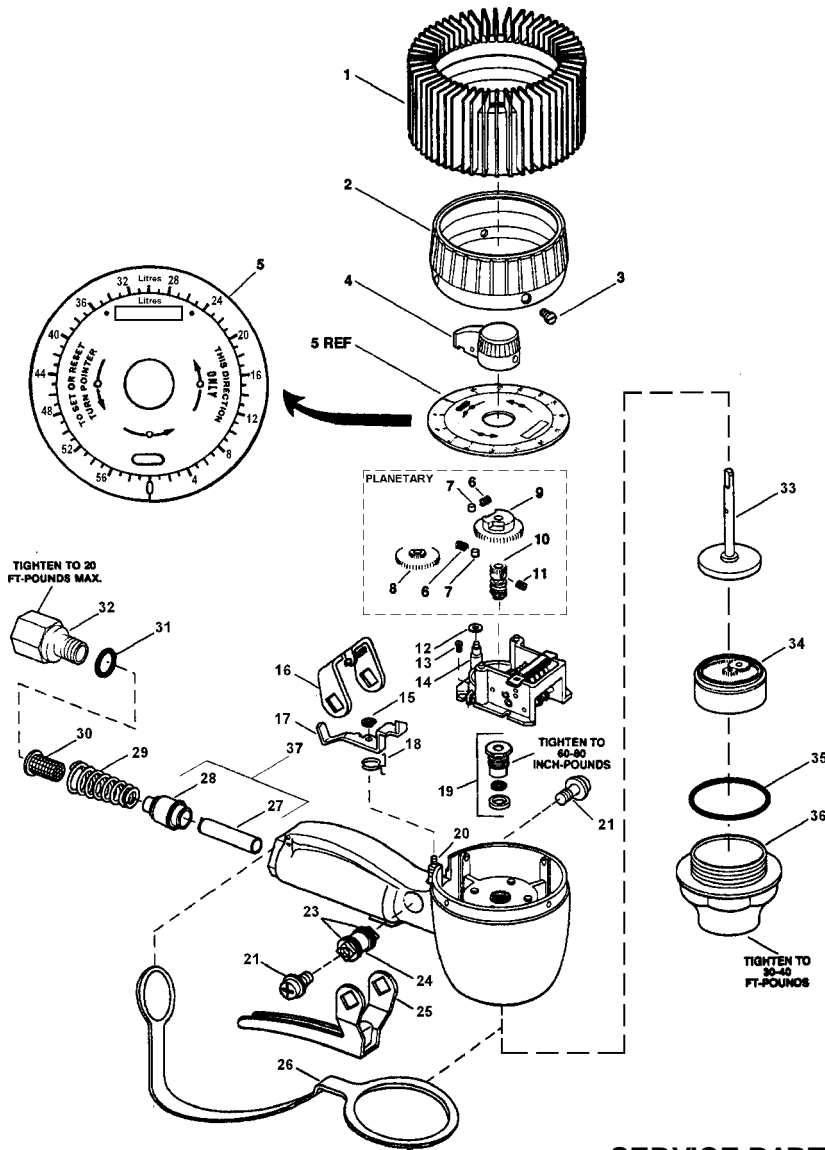

SERVICE PARTS

Item	Part No.	Qty.	Description	Item	Part No.	Qty.	Description
1	242911	1	*Shroud Protector	20	236400	1	Pin Lock Pawl
2	68410-12	1	Shroud	21	68410-2	2	Screw
3	66871 -5	4	Shroud Screw	22			
4	242913	1	Knob Assembly	23	68410-4	2	Quad Ring
5	69795-1	1	Dial Assembly	24	69304-2	1	Cam
6	66871-3	2	Clutch Spring	25	69304-4	1	Trigger Assembly
7	66871-4	2	Clutch Roller	26	69304-24	1	Hand Guard
8	69304-9	1	Compound Gear Assembly	27		1	** Valve Sleeve Assembly
9	69304-10	1	Preset Knob Drive Cam	28		1	** Valve Seat Assembly
10	69795-2	1	Worm Assembly	29	69304-3	1	Spring
11	50541	1	Set Screw	30	68410-27	1	Screen
12	69304-23	1	Washer	31	243176	1	O-Ring
13	70457-7	4	Screw	32	243175	1	Adapter
14	69795-3	1	Register Assembly	33	69795-4	1	Upper Driving Pawl Gear Assembly
15	69304-14	1	E-Ring	34	69795-5	1	Chamber and Piston Assembly
16	69304-5	1	Lockbar	35	66871-12	1	O-Ring
17	69304-13	1	Lock Pawl	36	68410-14	1	Cap
18	69304-12	1	Lock Pawl Spring	37	271700	1	Valve Assembly
19	237388	1	Packing Kit				

* May be purchased separately

** See valve assembly item 37