



CAUTION

BEFORE METER CAN BE PLACED IN SERVICE "AFTER REPAIR", METER MUST BE TESTED AND APPROVED IN ACCORDANCE WITH U.S. GOVERNMENT'S WEIGHTS AND MEASURES STANDARDS.



CAUTION

NEW METERING SYSTEMS MUST BE PURGED PRIOR TO INSTALLATION OF METERING CONTROL VALVE TO FREE SYSTEM OF CONTAMINATES.

DESCRIPTION

The electronic lube meter is designed specifically to dispense motor oils (S.A.E. 5-50), gear oils (S.A.E. 80-240), automatic transmission fluid, and antifreeze (Ethylene Glycol) solution.

The electronic register module contains a microprocessor board powered by a Lithium battery with an expected life of 3 to 5 years depending on use. It can be programmed to dispense in pints, quarts, liters, or gallons and will totalize in liters or gallons. A calibration factor and unit of measure are programmed during factory test. Unlike mechanical meters, these units can be electronically re-calibrated in the field when necessary. A 5-digit liquid crystal display, accurate to the second decimal place, shows the exact amount of fluid dispensed. The entire register module is protected from the wear and tear of normal shop use by a rugged, glass filled, shock resistant, nylon housing.

OPERATION

As fluid passes through the metering chamber by entering the inlet port, it displaces the piston and exits through the outlet port. Each oscillation of the piston displaces a given volume of fluid. Controlled clearances between the piston and chamber wall insure minimum leakage. As the piston oscillates, its center hub rotates a magnet which activates the microprocessor.

Depressing the RESET button before each use resets the totalizer to zero. Squeezing the trigger handle dispenses the fluid.

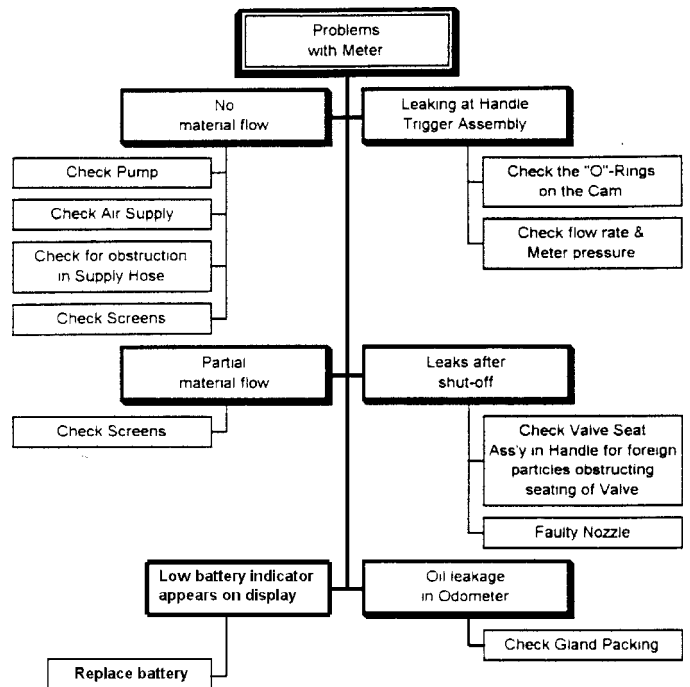

The total amount of fluid dispensed from inventory can be checked periodically by depressing the TOTAL button. If the units dispensed are pints, quarts, or gallons, the totalizer will read in gallons. If the units dispensed are liters, the totalizer will read in liters.

FEATURES

- Large LCD Display
- Two Decimal Point Precision
- Push Button Calibration
- Totalization in Gallons or Liters
- Delivery in Pints, Quarts, Liters, or Gallons
- Fewer Moving Parts To Help Reduce Maintenance Costs
- Improved Accuracy up to 0.4%
- Low Battery Indicator
- Replaceable Battery
- Battery Shelf Life - 10 Years
- Lock On

SPECIFICATIONS

Flow (Maximum)	4 GPM (15 Liter/Minute)
Flow (Minimum)	0.25 GPM (0.95 Liter/Minute)
Operating Pressure (Maximum)	1500 PSI (100 Bar)
Operating Pressure (Minimum)	5 PSI (0.35 Bar)
Operating Temp. (Maximum)	110° F (45° C)
Operating Temp. (Minimum)	-10° F (-20° C)
Accuracy (Non-Approved Ver.)	+/- 0.5%
Accuracy (Approved Version)	+/- 0.4%
Weight	3.0 Lbs. (1.36 KG)
5-Digit LCD Display, 5/16" high	Gallons
Inlet and Outlet Connections	1/2" NPTF (1/2" BSPP)

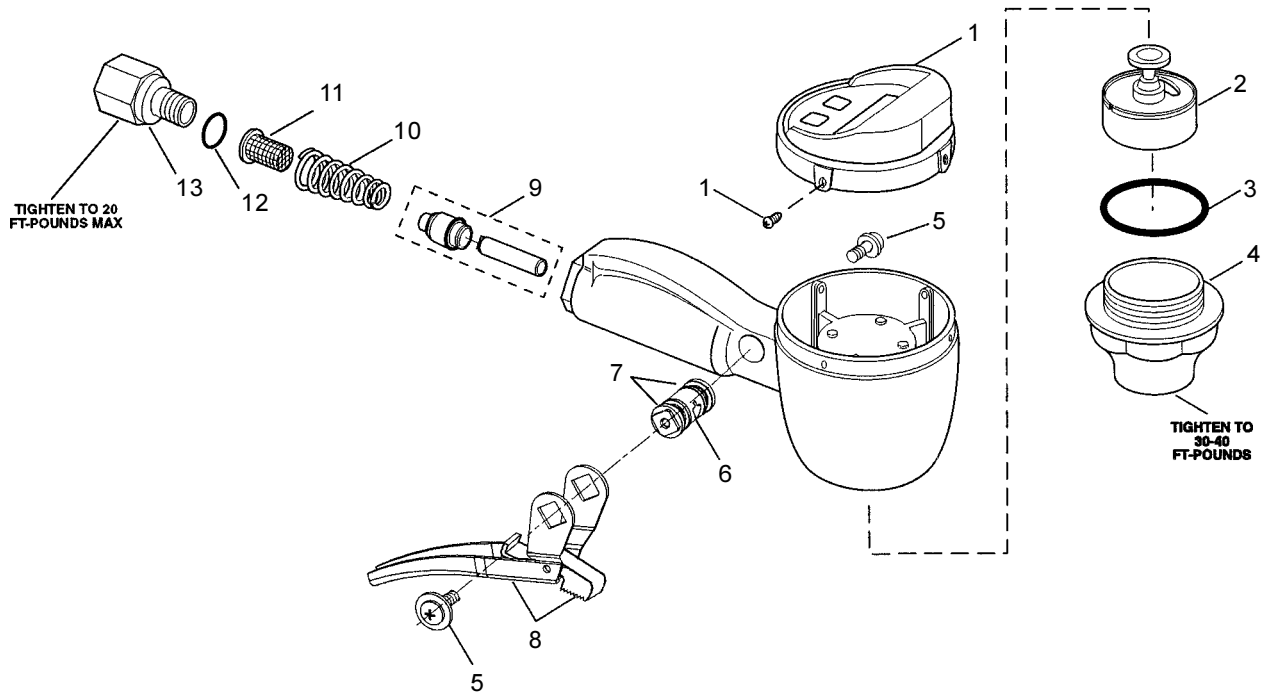
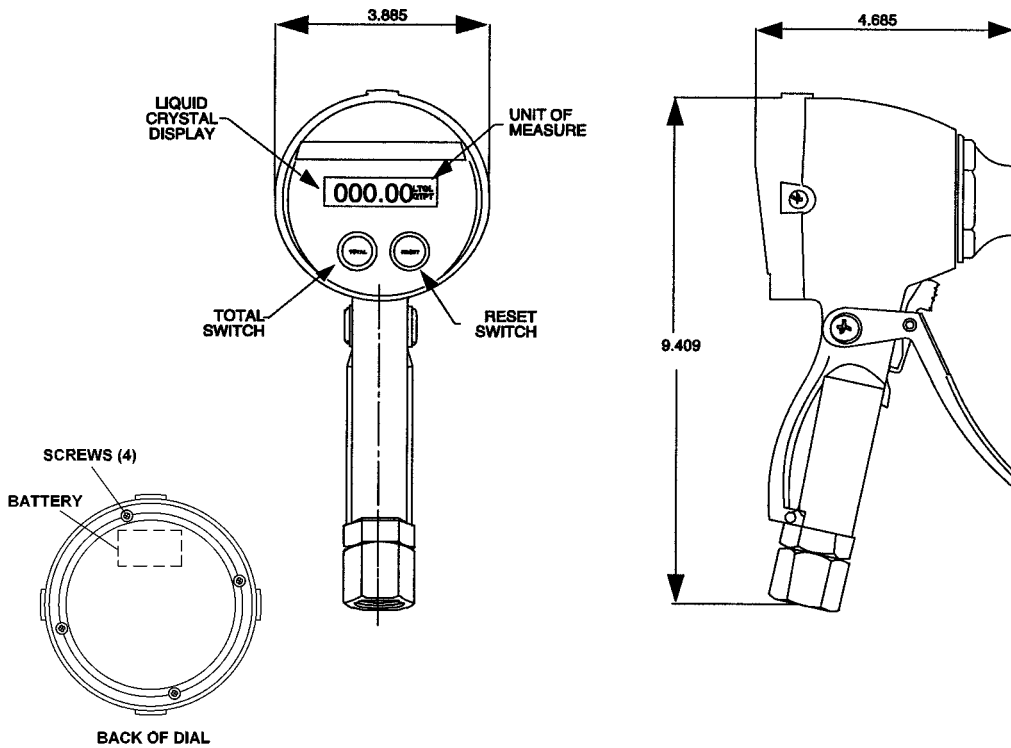

SERVICE PARTS

Item	Description	Part No.	Item	Description	Part No.
1	Register Module	245447	8	Trigger Assembly	68410-1
2	Chamber & Magnet Assembly	242319	9	Valve & Seat	68410-25
3	O-Ring	66871-12	10	Spring	69304-3
4	Housing Cap	68410-14	11	Screen	68410-27
5	Screw	68410-2 (2)	12	O-Ring	242320
6	Cam	68410-5	13	Adapter	243321
7	Quad Ring	68410-4 (2)			

BATTERY REPLACEMENT:

Remove dial from meter, remove 4 screws from back of dial to access battery. Remove battery and replace with lithium 1/2AA Battery. After battery replacement, meter must be reprogrammed.

PROGRAMMING INSTRUCTIONS

• PROGRAMMING SWITCH

Located on underside of module. Must be depressed 5 seconds and released to activate the programming procedure.

• TOTAL BUTTON

- a.) When depressed alone, it will display total GALLONS or LITERS used from inventory.
- b.) When depressed in the programming mode, it will allow you to select any item to be changed.

• RESET BUTTON

- a.) When depressed momentarily, it will clear the display.
 - b.) When depressed in the programming mode, it will change any flashing object on the display.
- ### • TO CHANGE UNITS OF MEASURE
- a.) Remove 3 screws holding electronic register module to lube meter body.
 - b.) Depress the PROGRAMMING switch on bottom of module for 5 seconds and release to activate the programming procedure. A unit of measure symbol will flash.
 - c.) Toggle RESET button until desired unit of measure symbol appears.
 - d.) Again depress the PROGRAMMING switch on bottom of module for 5 seconds and release to end the programming procedure. This operation will lock in the selected program and blank the display.

NOTE: Changing any unit of measure will reset the totalizer to zero.

• TO RECALIBRATE

Example: Meter delivers 4.200 quarts.
Display shows only 4.000 quarts dispensed.
 $4.2(\text{qty. delivered}) \text{ divided by } 4.0(\text{qty. displayed}) = 1.05 \text{ (error factor)}$

- a.) Display existing meter correction factor by depressing and holding TOTAL and RESET buttons.
Example: 0.995. (Make a note of this number.)
- b.) Calculate a new meter correction factor: $0.995 \text{ (existing meter correction factor)} \times 1.05 \text{ (calculated error factor)} = 1.045 \text{ (new meter correction factor)}$.
- c.) Remove 3 screws holding register module to meter.
- d.) Depress the PROGRAMMING switch on bottom of module for 5 seconds and release to activate the programming procedure.
- e.) Display will show existing meter correction factor and programmed unit of measure symbol will be flashing.
- f.) Toggle TOTAL button until left most correction factor digit that you wish to change begins to flash.
- g.) Toggle RESET button until desired digit (1) appears.
- h.) Toggle TOTAL button until the next digit you wish to change begins to flash.
- i.) Toggle RESET button until the desired digit (0) appears.
- j.) Toggle TOTAL button until the next digit you wish to change begins to flash.
- k.) Toggle RESET button until the desired digit (4) appears.
- l.) Toggle TOTAL button until the next digit you wish to change begins to flash.
- m.) Toggle RESET button until the desired digit (5) appears.
- n.) Again depress the PROGRAMMING switch for 5 seconds and release to end the programming procedure. This operation will lock in the selected program and blank the display. Reinstall the register to the lube meter.

NOTE: After programming, display will be blank. Depress RESET or TOTAL button to reactivate the display.

NOTE: Original meter correction factor is written on top of meter housing in black ink when factory calibrated. It may have been revised after field installation. Use correction factor shown on display.

Americas:
One Lincoln Way
St. Louis, MO 63120-1578
USA
Phone +1.314.679.4200
Fax +1.800.424.5359

Europe/Africa:
Heinrich-Hertz-Str 2-8
D-69183 Walldorf
Germany
Phone +49.6227.33.0
Fax +49.6227.33.259

Asia/Pacific:
25 Int'l Business Park
#01-65 German Centre
Singapore 609916
Phone +65.562.7960
Fax +65.562.9967

© Copyright 2001
Printed in USA

Web site:
www.lincolnindustrial.com