

CAUTION

Before meter can be placed in service "After Repair", Meter must be tested and approved in accordance with U.S. Government's Weights and Measures Standards.

CAUTION

New metering systems must be purged prior to installation of metering control valve to free system of contaminates.

OPERATION

The meter can handle petroleum products such as automatic transmission fluid, S.A.E. 5 to 50 weight motor oil, S.A.E. 80 to 240 weight gear oil and antifreeze fluid (ethylene glycol). The meter can be locked in the on position by engaging the trigger lock, to release the lock the trigger must be depressed thus releasing the lock. Before each use reset the meter by rotating the indicator knob counter-clockwise to zero.

SPECIFICATIONS:

Dial Capacity	1 to 10 liters
Totalizer	Liters
Flow Max.	4 Gallons per min. (15 liters per min.)
Flow Min.	0.4 Gallons per min. (1.5 Liters per min.)
Operating Pressure Max.	1000 PSI (70 Bar)
Operating Temp. Max.	110°F (45° C)
Accuracy	+/- 0.65%
Weight	3.3 Lbs. (1.5 Kg.)
Meter Inlet & Outlet Thds.	1/2 NPTF

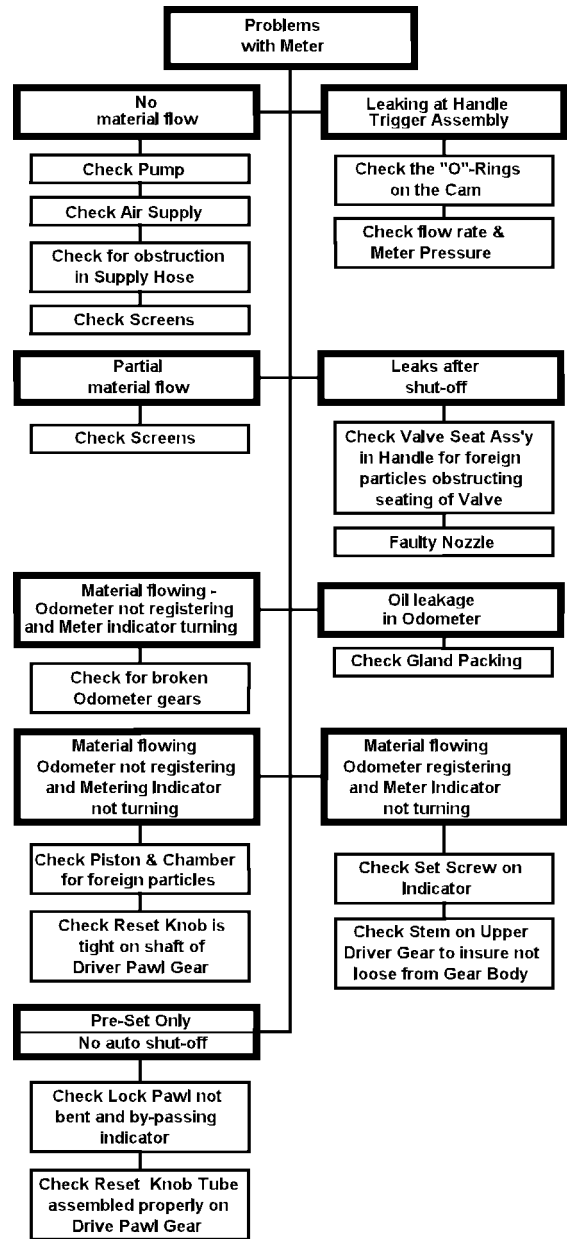

Americas:
One Lincoln Way
St. Louis, MO 63120-1578
USA
Phone +1.314.679.4200
Fax +1.800.424.5359

Europe/Africa:
Heinrich-Hertz-Str 2-8
D-69183 Walldorf
Germany
Phone +49.6227.33.0
Fax +49.6227.33.259

Asia/Pacific:
25 Int'l Business Park
#01-65 German Centre
Singapore 609916
Phone +65.562.7960
Fax +65.562.9967

© Copyright 2001
Printed in USA

Web site:
www.lincolnindustrial.com



CAUTION

DO NOT TURN POINTER IN A CLOCKWISE DIRECTION AS THIS WILL DAMAGE METER.

The pointer can only be returned to the zero stop in a counterclockwise direction after delivery.

Inner circle indexes in full liters to ten liters.
Outer circle indexes in tenths of one liter.

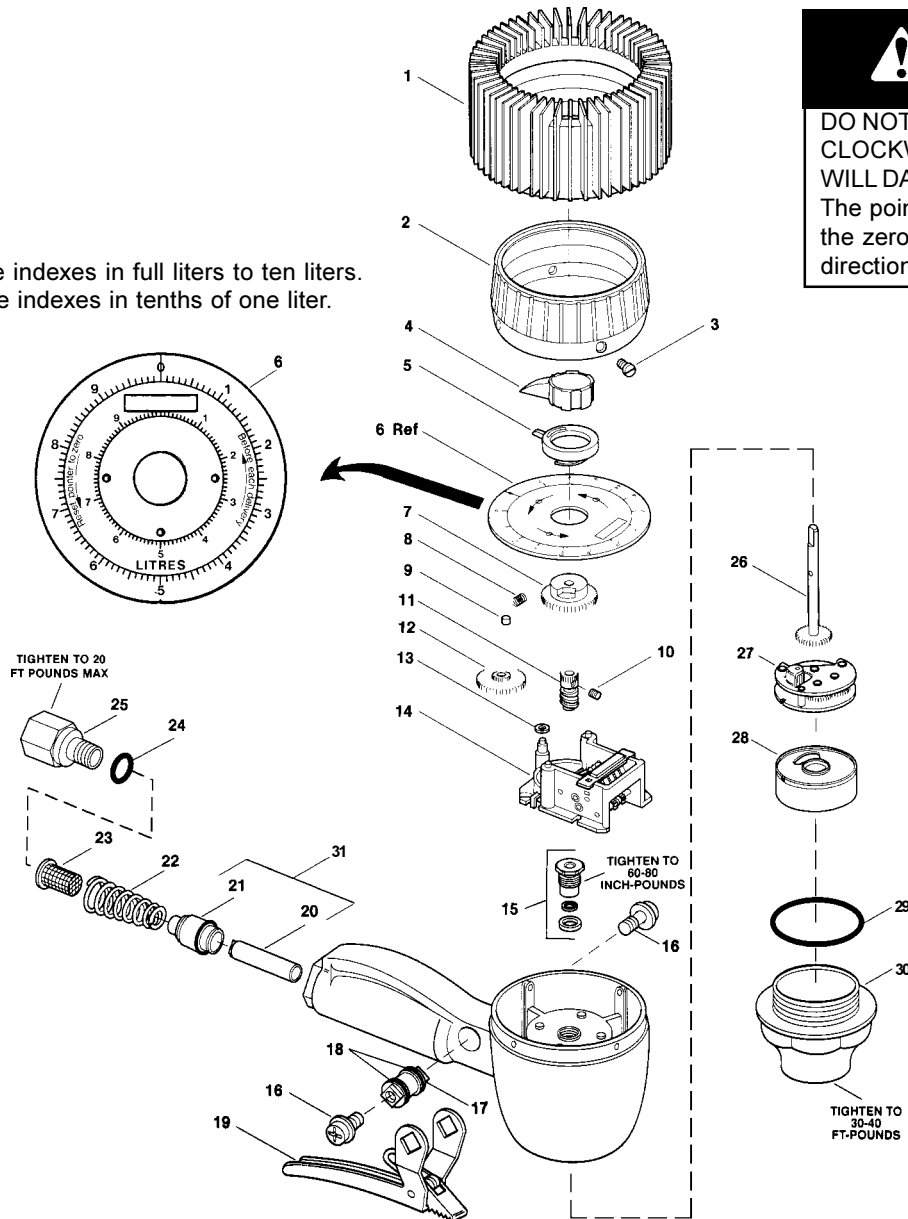

Service Parts

ITEM	DESCRIPTION	Part No.	ITEM	DESCRIPTION	Part No.
1	*Shroud Protector	242911	16	Screw	68410-2 (2)
2	Shroud	68410-12	17	Cam	68410-5
3	Shroud screw	66871-5 (4)	18	O-ring	68410-4 (2)
4	Knob assembly	242912	19	Valve trigger assembly	68410-1
5	Inner circle pointer	66871-53	20	**Valve sleeve assembly	
6	Dial assembly	69235	21	**Valve seat assembly	
7	Inner circle pointer cam	68499-30	22	Spring	69304-3
8	Clutch spring	66871-3	23	Screen	68410-27
9	Clutch roller	66871-4	24	O-ring	243176
10	Set screw	50541	25	Adapter	243175
11	Upper driving pawl worm gear	68602-7	26	Upper driving pawl gear assembly	66871-138
12	Inner circle pointer gear	66871-134	27	Spur gear train assembly	66871-136
13	Spacer	69304-23	28	Chamber & piston assembly	66871150
14	Register assembly	68602-8	29	Housing cap gasket	66871-12
15	Packing kit	237388	30	Housing cap	68410-14
			31	Valve Assembly (Buna-N)	271699

Quantity

* May be purchased separately

** See valve assembly item 31