

CAUTION

BEFORE METER CAN BE PLACED IN SERVICE "AFTER REPAIR", METER MUST BE TESTED AND APPROVED IN ACCORDANCE WITH U.S. GOVERNMENT'S WEIGHTS AND MEASURES STANDARDS.

CAUTION

NEW METERING SYSTEMS MUST BE PURGED PRIOR TO INSTALLATION OF METERING CONTROL VALVE TO FREE SYSTEM OF CONTAMINATES.

CAUTION

Always reset knob to zero by turning counterclockwise. IF TURNED CLOCKWISE, SEVERE INTERNAL DAMAGE WILL OCCUR!

OPERATION

The Meter can handle petroleum products such as automatic transmission fluid, S.A.E. 5 to 50 Wt. motor oil, S.A.E. 80 to 240 wt. gear oil and antifreeze fluid (ethylene glycol). Used primarily as a inventory control device in lubricant dispensing systems, it is accurate, rugged and light weight.

The pointer knob affixed to the output shaft rotates around a graduated dial, indicating the amount dispensed. After delivery, the knob is then reset to zero by turning it counterclockwise.

SPECIFICATIONS

Dial Capacity Outer (Graduations)	1 Liter (1/10 Liter)
Dial Capacity Inner	10 Liters
Totalizer	Yes
Flow (Maximum)	4 Gpm (15 Liters/Minute)
Flow (Minimum)	0.4 Gpm (1.5 Liters/Minute)
Operating Pressure (Maximum)	1000 Psi (70 Bar)
Operating Temperature (Maximum)	150° F (70° C)
Accuracy	+/- 0.65%
Weight	3.3 Lbs (1.5 Kg.)
Inlet And Outlet Connections	1/2" NPFT (1/2" BSPP)

OUTLET PORT POSITIONS (In Relation to Dial)

The outlet port can be set at any one of four positions, namely, 3, 6, 9, or 12 o'clock. The four positions are illustrated on the right, all in relation to the cipher on the dial. All meters, unless otherwise specified at the time ordered, will be set at the 6 o'clock position.

To change positions in the field, simply remove the shroud, the reset knob, and the dial. Rotate the dial until the outlet port is in the desired position, and reassemble the parts in reverse sequence.

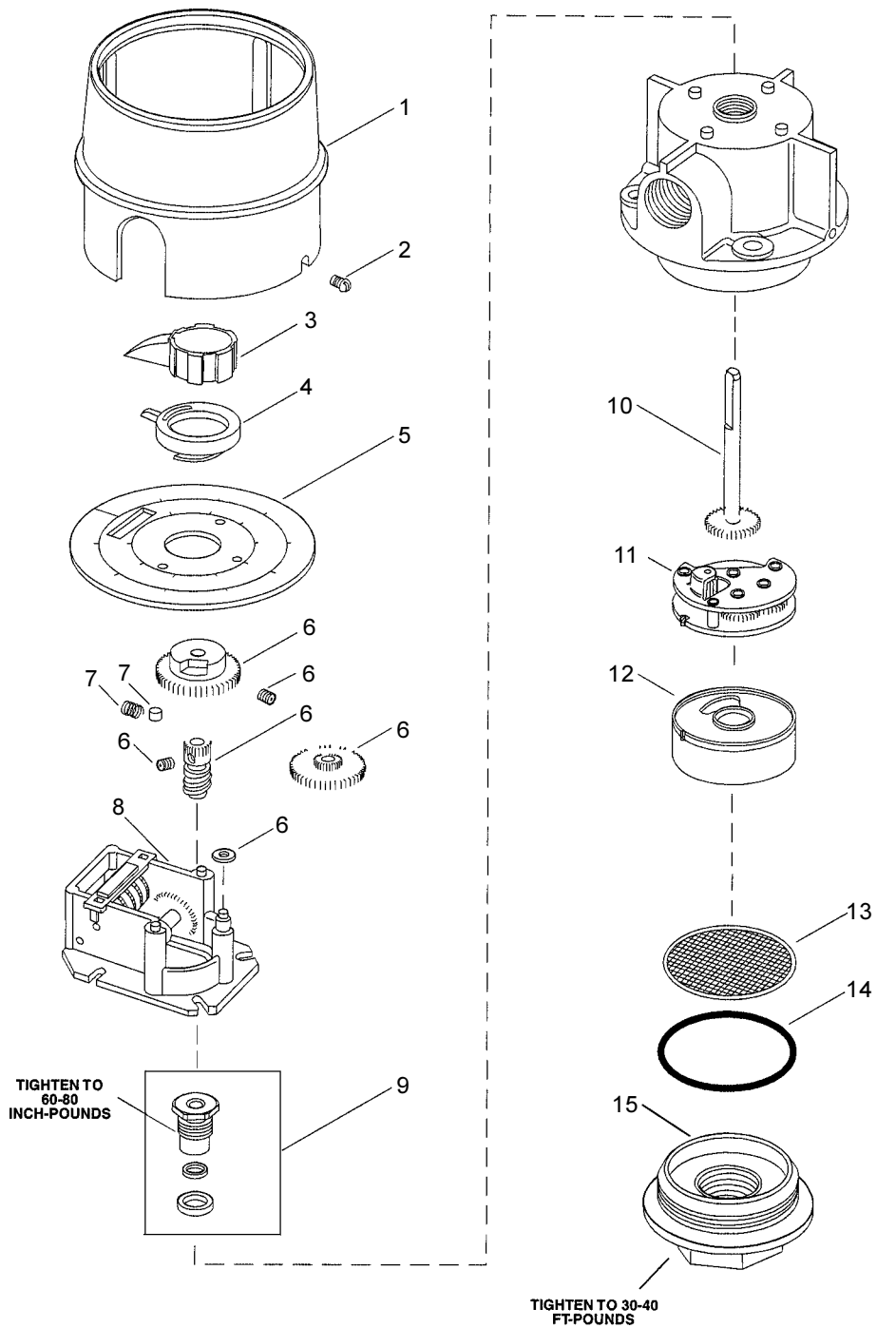

SERVICE PARTS

Item	Description	Part No.	Item	Description	Part No.
1	Shroud	66871-13	9	Packing Kit	237388
2	Shroud Screw	66871-5 (2)	10	Upper Driving Pawl Worm Gear	66871-138
3	Knob Assembly	242912	11	Gear Train Assembly	66871-136
4	Pointer Inner Circle	66871-53	12	Chamber & Piston Assembly	66871-137
5	Dial Assembly	69235	13	Screen	66871-92
6	Gear Kit	272158	14	O-Ring	66871-12
7	Clutch Kit	272155	15	Housing Cap	41204
8	Register Assembly	68602-8			