

27:1 RATIO

SPECIFICATIONS

	Min.	Max.
PRIMING PRESSURE	—	1,000 psi
AIR OPERATING PRESSURE	80 psi	100 psi
*OUTPUT PER CYCLE	.005 in ³	.045 in ³

*14302 Adjusting Screw controls the amount of output per cycle.

**Torque 13282 and 13283 to 25-30 ft.-lbs.

ADJUSTMENT PROCEDURE

Remove 16597 Stop Plug and 31110 Gasket. Loosen 16596 Adjustment Housing one half to one full turn. Insert screwdriver into adjustment housing and turn 14302 Adjusting Screw counter-clockwise to increase output or clockwise to decrease output. After completing adjustment, tighten adjustment housing while holding adjusting screw with screwdriver. Replace gasket and stop plug.

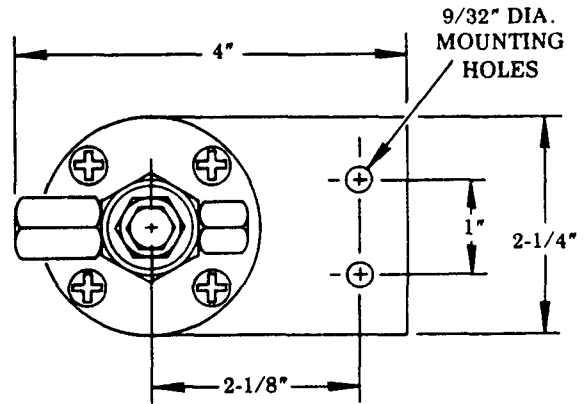
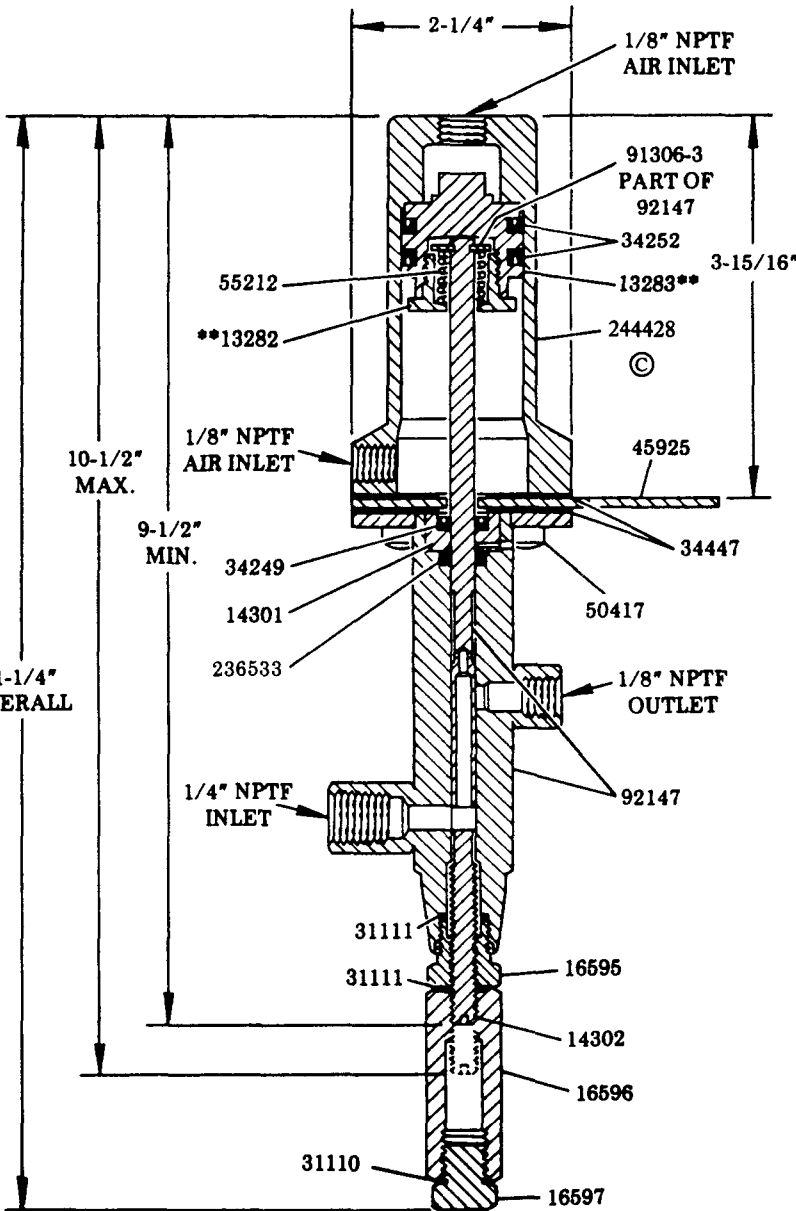

© Indicates Change

SERVICE PARTS

Part	Qty.	Description	Part	Qty.	Description	Part	Qty.	Description
13282	1	Spring retainer nut	31110	1	Gasket	55212	1	Spring
13283	1	Piston	31111	2	Gasket	91306-3	1	Washer
14301	1	Spacer	34249	1	U-cup packing (Buna-N)	92147	1	Plunger assembly
14302	1	Adjusting screw	34252	2	U-cup packing (Buna-N)	236533	1	Packing (Viton)
16595	1	Adjusting screw adapter	34447	2	Gasket (Nitrile)	244428	1	Air cylinder
16596	1	Adjustment housing	45925	1	Bracket			
16597	1	Stop plug	50417	4	Screw			