

# SIPHON CLEANING GUN

FOR USE WITH SOLVENTS OR DETERGENT SOLUTIONS  
COMPATABLE WITH VINYL, ALUMINUM AND CARBON STEEL

# Model 939

## Series "B"

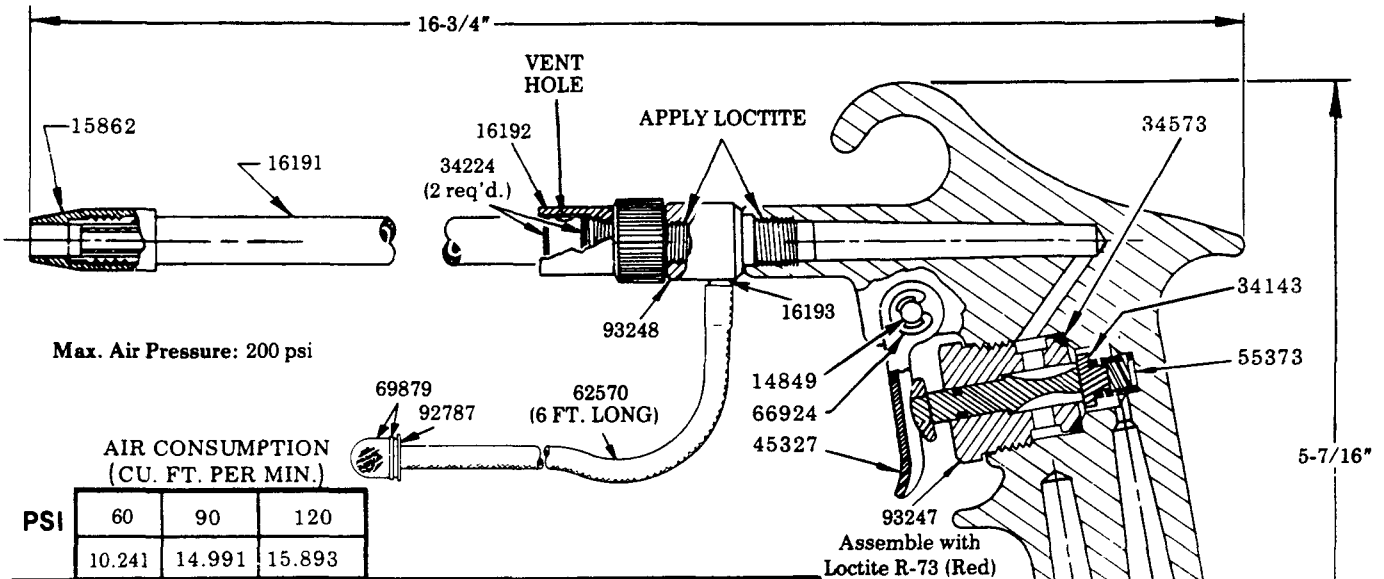

AIR CONSUMPTION  
(CU. FT. PER MIN.)

PSI	60	90	120
	10.241	14.991	15.893

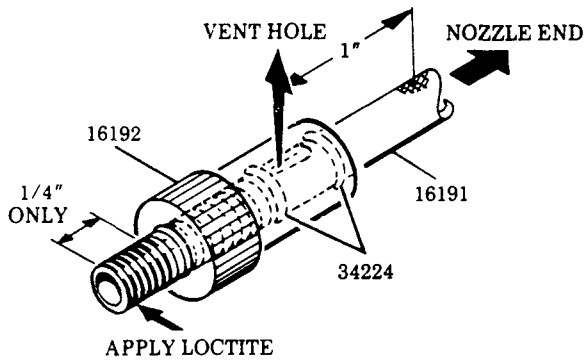

**CAUTION**

DO NOT USE WITH GASOLINE.  
USE IN WELL-VENTILATED  
AREAS, AWAY FROM OPEN  
FLAME AND LIT CIGARETTES.  
AVOID BREATHING VAPORS.  
WEAR EYE PROTECTION.  
WEAR RESPIRATOR.

### OPERATION

Submerge end of 62570 Tubing with strainer into cleaning solution. Adjust air pressure as desired. Regulate flow by rotating 16192 Sleeve Nut.

### ASSEMBLY

Before beginning assembly, place a mark with a suitable marker at least 1 inch from vent hole on 16191 Tube (as illustrated) to assure proper placement of vent hole.

Screw 16192 Sleeve Nut as far as possible onto pipe nipple. Apply Loctite #271 (Red) to first 1/4" of threads only. Screw pipe nipple into 93248 Body & Tube Assembly as far as possible, then back out until vent hole mark on nipple and tubing connection on body & tube assembly are 180° apart.

**NOTE:** Excess loctite must be wiped from threads.

Apply loctite to 93248 Body & Tube Assembly and screw into 41262 Air Gun Body, then back out until tubing connection is pointing downward, then check to be sure vent hole is pointing up. Screw 15862 Nozzle on pipe nipple.

© Indicates change

### SERVICE PARTS

PART	DESCRIPTION
14849	Pin
15862	Nozzle
16191	Tube
16192	Sleeve nut
16193	Tube adapter
34143	Valve disc
34224	O-ring
34573	O-ring
41262	Air gun body
45327	Trigger
55373	Check spring
62570	Vinyl tubing
66924	Retaining ring
69879	Strainer assembly
92787	Strainer tube assembly
93247	Actuator assembly
93248	Body & tube assembly



LINCOLN, One Lincoln Way  
St. Louis, Missouri 63120-1578  
(314) 679-4200 Customer Service, (314) 679-4300

SECTION - F53  
PAGE - 6B